



NEW TECHNOLOGY FOR TOUGH DEWATERING

ENG 50 HZ

PUMPEX

WELCOME TO PUMPEX, ONE OF THE WORLD'S LEADING MANUFACTURERS



Dedicated Dewatering

All our authorized distributors are trained in pump application pump selection, and they are supported by our engineers and our state-of-the-art Pumpex pump selection software, PUMPEXplorer®.

For professional use

Submersible dewatering pumps are used in a wide range of applications when water need to be moved, at construction sites, for irrigation, in ship yards, by utility companies, in rescue ships, by fire brigades, in mines and quarries, in general industries, by power companies etc. Pumpex wide range of dewatering pumps is the perfect choice for most of these applications.

Solid Quality

Since our start we have developed our products to meet the increasing demands of an international market.

At Pumpex, quality means:

- Latest technology
- Robust design
- High grade materials
- Trouble-free operation
- Ease of service



FACTURERS OF SUBMERSIBLE DEWATERING PUMPS.



Construction and mining applications, as well as industrial, municipal and agricultural needs, have influenced our Swedish engineers in the development, design and production of Pumpex professional dewatering pumps. Maintained efficiency is a key factor to operating economy together with high-efficiency motors and hydraulics.

Company

Pumpex is a part of the Sulzer Group, a Swiss based company with over 3 billion Euro turnover and 15 000 employees around the world. Sulzer is public company listed on the Swiss Stock Exchange (SIX).

Dedicated Partner

Pumpex is a complete equipment supplier for professional dewatering applications. With over 50 years experience in submersible dewatering pumps. Our high quality products and engaged know-how provides a reliable support for our partners and customers in over 70 countries around the world. Our pumps combine high reliability with excellent serviceability, which results in unrivalled operating economy.

Contact

Pumpex products are sold, rented and serviced by professional distributors all around the globe. Together with our distributors, we work hard to meet the demands of our end-users, for whom the availability of products, spares and support is vital.





NEW TECHNOLOGY FOR TOUGH DEWATERING.

Pumpex SUPER Drainers, series PS and SPS, are introducing lots of new technology to the dewatering market, making dewatering easier and safer for miners, contractors, industrial users and other professionals with tough applications where reliability, easy handling and availability is essential.

SUPER

Safe, User friendly, Powerful, Economic, Reliable

SUPER Drainer

The new technology in Pumpex SUPER Drainer pumps equipped with Pumpex WIP Control offers significant improvements of many aspects of the pumps life cycle by making the pump:

Safe

- **High motor temperature protection** by Bi-metal sensors and NTC thermistors in the motor winding, for continuous temperature recording and auto-stop at over-temperature, 145 °C.
- **High WIP temperature protection** by built-in NTC thermistors at the WIP Computer with auto-stop at over-temperature.
- **Built-in overload protection** for continuous amperage recording and auto-stop at overload.
- **Phase-failure protection, incorrect power.** Pump stops in case of phase failure or to high phase unbalance in power supply.
- **Moisture monitoring of shaft seals and motor.** Moisture sensors in oil and motor housing, with LED indication in the WIP Plug in case of moisture.

User friendly

- **Automatic rotation correction.** WIP Computer with dual contactors automatically ensures correct rotation.
- **Automatic restart.** Pump re-starts automatically if stopped due to overheating, power failure, over amperage.
- **All data and operation history accessible via USB.** Technical data, spare parts info, service instructions, pump history, operation performance etc. are stored in the built-in WIP Computer accessible on PC via USB connection.
- **Built-in starter.** DOL starters with dual contactors for smaller pumps and VFC Soft Starter as standard above 7 kW.
- **External easy-to-reach check points for shaft seals and motor** by external check plugs.

Powerful

- **High efficiency hydraulics** by new design of impellers and diffusers for highest efficiency over a larger part of the performance range.
- **Maintained performance over time** by resistant and adjustable wear rings and diffusers to keep the performance and efficiency at maximum over time even in the toughest applications.

PUMPEX SUPER DRAINERS

PS 1000 - PS 3000

SPS 30 - SPS 80

SUPER DRAINERS

Safe
User friendly
Powerful
Economic
Reliable

WIP CONTROLS

Watching
Indicating
Protecting

- **Extreme performance - weight ratio.**
Low weight versus high performance, for easy transport and handling at site.
- **High service factor.**
Service factor of over 1.2, together with class H, 185 °C, insulated windings used to max 145 °C, safe guard continuous performance even at harsh conditions, with voltage drop, overload conditions, temporary over-temperature, etc.

Economic

- **High or premium efficiency motors IEC2.**
- **Auto start-stop.**
Auto-stop when pump start snoring and start by level sensor to save energy and reduce excess wear.
- **Easy service check via PC.**
Pump's condition and any need for service as well as performance record, service history and other information for the pump unit, is all easy readable on a PC connected to the pump top by an external USB port.
- **Minimum down time by easy maintenance at site.**
Easy service by consistent design with standardized spare parts and no need for special tools makes service easy even at site, reducing cost for transportation, handling and down time.
- **Standardized spare parts and service kits.**
Fewer parts to cover many pump sizes and easy-to-order service kit, reduces the need for part in stock still ensuring that the right parts are available when needed.

Reliable

- **High wear resistance.**
60 RH hard impellers and wear ring of white cast iron and rubber covered diffusers and wear plates for maximum wear resistance at harsh condition.
- **Double mechanical shaft seal.**
Silicon carbide against silicon carbide in both primary and secondary mechanical shaft seals.

- **Double sealed non-wicking cable entries** are leak-proof even if cables are destroyed, approved standard cable can be fitted at site.
- **Lubricated for life bearings.**
Highest quality, lubricated-for-life bearings for minimum 50 000 Hours B2 life.
- **Advanced anti-blocking re-start sequence** by a 3x3-stage re-start sequence with auto-reverse, to safeguard re-start even at most difficult condition with blocked impeller.
- **Work in toughest conditions.**
Dry, semi dry or totally submersed, in any position, standing up, lying down or even up-side-down, the SUPER Drainer still works continuously without stopping.

WIP Watching, Indicating, Protecting

WIP Control

The WIP Control is not only making all external starters and controls obsolete but also offer a lot of important features, reducing costs and making life easier and more efficient for the user, such as.

- **Selectors for operation mode.**
- **Indicators for selected operation mode, pump condition, over-temperature, moisture in oil or motor, low motor insulation and power supply condition.**
- **PC connection for operation and pump history, pump diagnostic, service protocol, technical and service information and a lot more.**

Pumpex WIP Control System consists of the WIP Computer built into the SUPER Drainer pump, storing all data about the pump, and the easy to use robust WIP Plug at the power supply. The two units are communicating data over the power cable.

PUMPEX SUBMERSIBLE DEWATERING PUMPS SERIES P, PS, PSG, PX, SP AND SPS

Pumpex submersible dewatering pumps series P, PS, PSG, PX, SP and SPS are suitable for pumping water and dirty water mixed with sand and soil. The low weight and compact design vouches for convenient transport, handling and installation. Just plug and pump!

No suction lift limitations

Pumpex dewatering pumps are submersible to 20 m depth and have no suction lift limitations. As the pump is installed submerged in the pit it does not need to be moved with varying water levels. There are no suction hoses, and no vacuum priming issues. Pumpex pumps are designed to run dry in case the water level drops too low.

High reliability

Double mechanical shaft seal in oil bath (silicon carbide on silicon carbide in the primary seal) for long life. Rigid stainless steel shaft with lower double angular contact ball bearings for vibration-free operation. The drainage pumps large strainer area minimizes the risk of clogging and the sludge pumps open volute with vortex impeller provides excellent solids handling.

Trouble free and safe handling

Pumpex dewatering pumps are equipped for immediate use. The low weight, encapsulated motor and no external moving parts together with built-in starter makes installation and operation easy and safe.

High wear resistance

Drainage pumps have impeller in high chrome alloy steel with a hardness of 60 Rc. Adjustable wear parts with diffusers covered with oil resistant nitrile rubber and wear rings of high chrome alloy steel to secure a long lifetime with maintained high efficiency.

Sludge pumps have pump housing and impeller in wear resistant ductile iron with stainless steel impeller as option for extreme conditions.

Plug-in start with motor protection

Built-in contactor, capacitor (Single Phase) and thermal protectors in the stator windings protects the motor and features an automatic restart function.

High flexibility

All pumps can operate in every position, vertical, horizontal or even upside down. They can easily be converted between standard, high head or high flow versions.

Corrosion resistant

Outer casing, rotor shaft and hardware are made of stainless steel. Casted parts are made in lightweight aluminium alloy or ductile iron, externally with a protective two-component epoxy coating.

Can run dry

Double outer casing and good heat convection make it possible to run the pump dry or on snore, with a mixture of water and air, without overheating.

Easy service and maintenance

Common philosophy through the complete range, with modular design and interchangeable spare parts. (For example identical shaft seals for P 601 - P 801 and SP 10 - SP 14 and for PS 1000 - PS 3000 and SPS 30 - SPS 80.)

- Easy access to separate sealed electrical junction box.
- Easy to adjust or replace hydraulic wear parts.
- Few parts needed to cover many different pump models.

Environmentally safe

The oil housing is filled with environmentally safe white oil. Non toxic two-component epoxy coatings are used.

Environmental Product Declaration

Environmental Product Declaration is a new system to present a products environmental impact during its entire life cycle. The environmental product declarations are based on product specific life cycle analyses, conducted in accordance with the ISO 14040-series.



PUMPEX OFFERS MORE FEATURES OF YOUR CHOICE

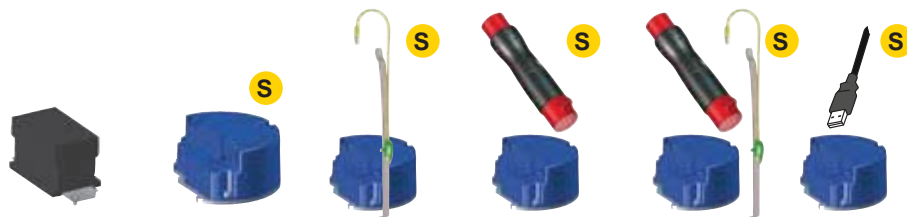

Pumpex features	Pump with built-in contactor	SUPER Drainer with built-in WIP Computer	Pump with WIP Computer and level sensor	Pump with WIP Computer and WIP Plug	Pump with WIP Computer, WIP plug and level sensor	Pump with WIP Computer and PC Com. Kit
	C1	S1	S2	S3	S4	S5
Run mode	✓	✓	✓	✓	✓	
Built-in starter	✓	✓	✓	✓	✓	
High motor temp stop - auto restart	✓	✓	✓	✓	✓	
Automatic restart after power failure	✓	✓	✓	✓	✓	
Automatic rotation correction		✓	✓	✓	✓	
Advanced automatic start sequenes, 3x3-stage with auto revers in case of blocked impeller		✓	✓	✓	✓	
High current auto stop - advanced restart		✓	✓	✓	✓	
Phase failure auto stop - advanced restart		✓	✓	✓	✓	
Automatic stop at dry running/snoring			✓		✓	
Level control - automatic start at preset water level			✓		✓	
Operation selector panel				✓	✓	
Operation mode indications				✓	✓	
Warning - moisture in motor				✓	✓	
Warning - water in oil				✓	✓	
Warning - low motor insulation				✓	✓	
E-mode set indication					✓	
Socket for external USB cable connection		✓		✓	✓	✓
Pump specific info - technical data, serial no etc						✓
Pump status examination						✓
Service requirement analysis						✓
Logg - pump operating history						✓
Logg - pump failure history						✓
Logg - pump service and maintenance history						✓
Digital spare parts documentation						✓
Digital workshop manual						✓

S Available exclusively in Pumpex SUPER Drainers, series PS, PSC and SPS.

PUMPEX SUBMERSIBLE DRAINAGE PUMPS

Pumpex submersible drainage pump are suitable for pumping water and dirty water mixed with soil. When delivered to a site you can start using them right away. The low weight and compact design vouches for convenient transport, handling and installation. Just plug and pump!

WIP Plug - **Eliminating the need for any other starters or controls.**

- Operation mode selection push-button.
- LED-illuminations to indicate operation mode.
- LED alerts for over-amperage, over-temperature, power supply problems and pump condition.

WIP Computer

- Auto stop at high amperage.
- Auto stop at high motor temp.
- Advanced auto re-start sequence in case of blocked impeller.
- Snore stop with auto start via level sensor.
- Data communication via power cable.
- Computer check of pump history, condition and data via USB connection.
- Verified maintenance with protocol.

External connection for service check and level sensor.

Double sealed, cable entry non-wicking.

Built-in starter: < 7 kW DOL-start
> 7 kW VFC Soft Starter (optional for PX 12)

Double casing for efficient cooling, also at dry or half-dry operation.

High efficiency motor, IEC2, with class H, 185 °C, insulated windings in PS and PSC pumps. Class F, 155 °C for P and PX pumps.

Simplified maintenance and service by modular design and standardized spare parts.

Extreme wear resistance with high-chrome alloy steel impellers and wear rings. Rubber covered diffusers.

Maintained efficiency by adjustable wear rings and diffusers.

Automatic rotation correction by phase order control and dual contactors.

Over temperature protection by Bi-metal sensors in motor windings. SUPER Drainers have also NTC sensors for continuous temperature control and recording.

Easy and fast check of oil and motor through external plugs. (P 601 – P 801 have internal plugs.)

Oil over-fill protection in oil casing.

Environmental safe by environmentally safe white oil and non toxic two-component epoxy coatings.

S Available exclusively in Pumpex SUPER Drainers, series PS, PSC and SPS.

PUMPEX P 401

Pump Type	W
Motor rating P_2	0.48 kW, 1~
Max. power input P_1	0.59 kW
Voltage (V)	230
Full load (A)	2.9
Speed	2690 rpm
Motor protection	Built in
Electric cable	10 m
Strainer passage	6 mm
Discharge connection	Hose 2"
	Option: G2"
Weight (excl. cable)	9.5 kg

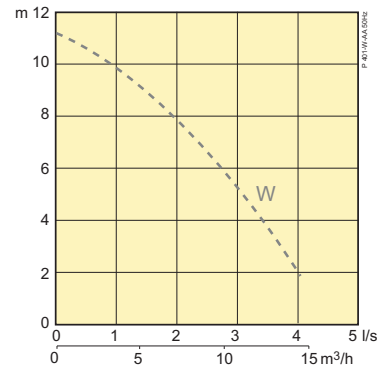
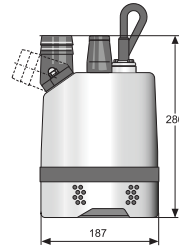

PUMPEX P 601

Pump Type	N / NA*	W / WA*
Motor rating P_2	1.0 kW, 3~	0.9 kW, 1~
Max. power input P_1	1.3 kW	1.2 kW
Voltage (V)	230/400/500	110/230
Full load (A)	4.0 / 2.3 / 1.9	10.4 / 5.2
Speed	2800 rpm	2750 rpm
Motor protection	Built in	
Electric cable	20 m	
Strainer passage	6.5 x 15.5 mm	
Discharge connection	Hose 2"	
	Option: 1½", 2½", 3", G2", G2½", G3"	
Weight (excl. cable)	16 kg	

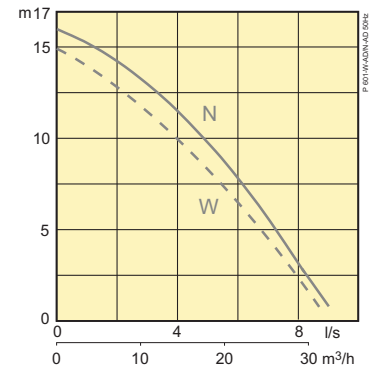
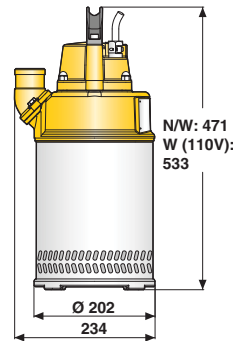

*) Built in float switch available as option, excl. 500V.

PUMPEX P 801

Pump Type	N / NA*	W / WA*
Motor rating P_2	1.4 kW, 3~	1.4 kW, 1~
Max. power input P_1	1.8 kW	1.9 kW
Voltage (V)	230/400/500	230
Full load (A)	5.0 / 2.9 / 2.3	8.1
Speed	2800 rpm	2800 rpm
Motor protection	Built in	
Electric cable	20 m	
Strainer passage	6.5 x 15.5 mm	
Discharge connection	Hose 2"	
	Option: 1½", 2½", 3", G2", G2½", G3"	
Weight (excl. cable)	16.5 kg (N), 18 kg (W)	

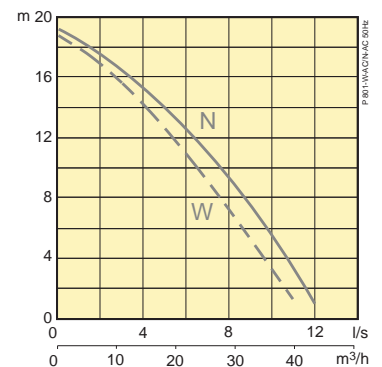
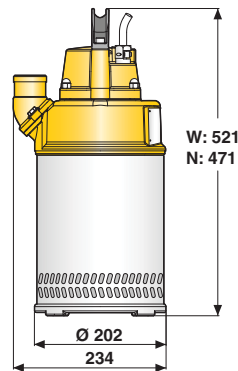

*) Built in float switch available as option, excl. 500V.

PUMPEX PS 1000 S

Pump Type	N / H / N WIP* / H WIP*
Motor rating P_2	2.5 kW, 3~
Max. power input P_1	2.9 kW
Voltage (V)	230 / 400 / 500 / 1000
Full load (A)	8.8 / 5.1 / 4.1 / 2.0
Speed	2920 rpm
Motor protection	Built in
Electric cable	20 m
Strainer passage	7.5 x 22 mm
Discharge connection	Hose 3"
	Option: 2½", 4", G2½", G3", G4"
Weight (excl. cable)	39 kg

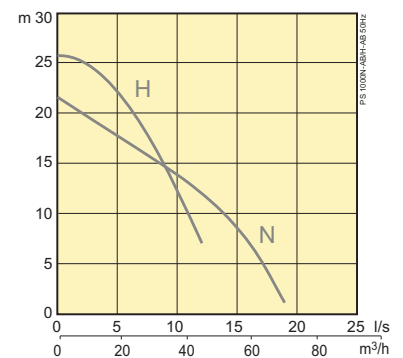
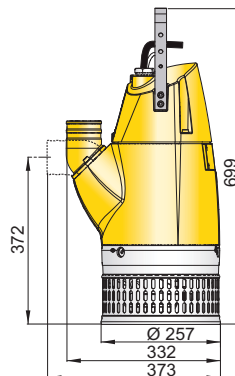

*WIP: Built-in WIP Computer.

PUMPEX PS 1500 S

Pump Type	N / H / N WIP* / H WIP*
Motor rating P_2	3.7 kW, 3~
Max. power input P_1	4.3 kW
Voltage (V)	230 / 400 / 500 / 1000
Full load (A)	13.2 / 7.6 / 6.1 / 3.0
Speed	2860 rpm
Motor protection	Built in
Electric cable	20 m
Strainer passage	7.5 x 22 mm
Discharge connection	Hose 3"
	Option: 2½", 4", G2½", G3", G4"
Weight (excl. cable)	42 kg

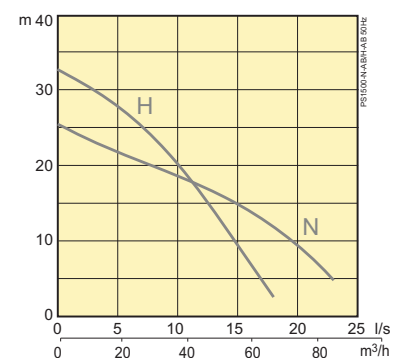
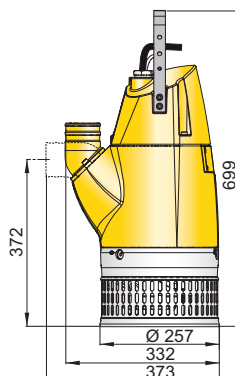

*WIP: Built-in WIP Computer.

PUMPEX PS 2000 S

Pump Type	N / V / H / N WIP* / V WIP* / H WIP*
Motor rating P ₂	5.6 kW, 3~
Max. power input P ₁	6.2 kW
Voltage (V)	230 / 400 / 500 / 1000
Full load (A)	19.7 / 11.3 / 9.0 / 4.5
Speed	2930 rpm
Motor protection	Built in
Electric cable	20 m
Strainer passage	7.5 x 22 mm
Discharge connection	Hose 3" (H), 4" (N), 6" (V) Option: G3", G4", G6"
Weight (excl. cable)	59 kg

*WIP: Built-in WIP Computer.

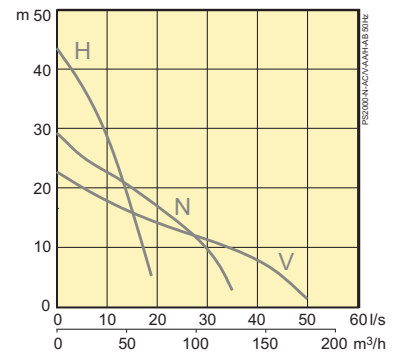
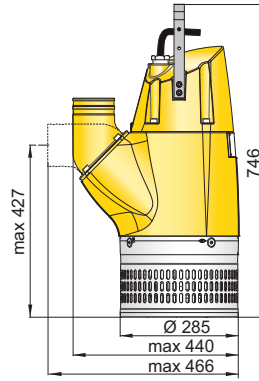

PUMPEX PS 3000 S

Pump Type	N / V / SH / N WIP* / V WIP* / SH WIP*
Motor rating P ₂	8.3 kW, 3~
Max. power input P ₁	9.3 kW
Voltage (V)	230 / 400 / 500 / 1000
Full load (A)	27.8 / 16 / 12.8 / 6.4
Speed	2920 rpm
Motor protection	Built in
Electric cable	20 m
Strainer passage	7.5 x 22 mm
Discharge connection	Hose 3" (SH), 4" (N), 6" (V) Option: G3", G4", G6"
Weight (excl. cable)	63 kg (N,V), 78 kg (SH)

*WIP: Built-in WIP Computer.

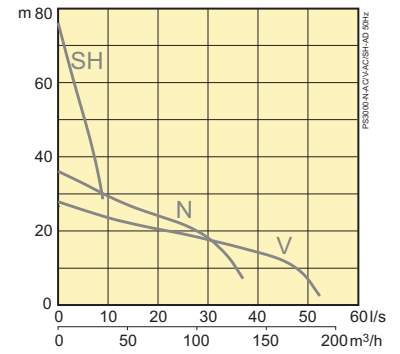
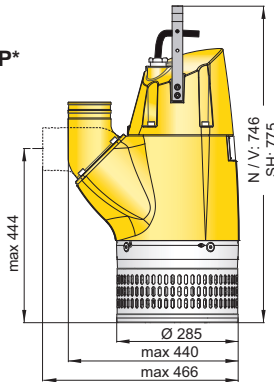

PUMPEX PX 12

Pump Type	N / H
Motor rating P ₂	21 kW, 3~
Max. power input P ₁	24 kW
Voltage (V)	230 / 400 / 500 / 1000
Full load (A)	68 / 39 / 31 / 16
Speed	2930 rpm
Motor protection	Built in
Electric cable	20 m
Strainer passage	8 x 34 mm
Discharge connection	Hose 4" (H), 6" (N) Option: 8", G4", G6", G8"
Weight (excl. cable)	155 kg

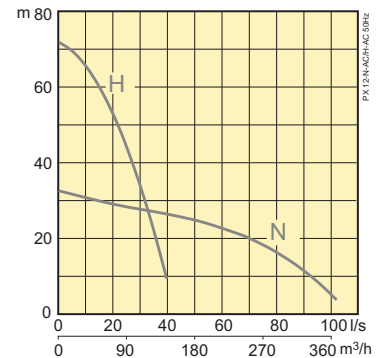
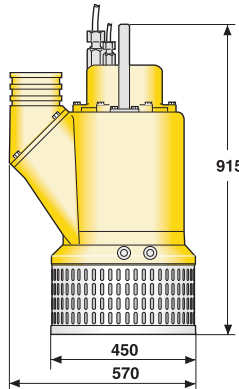

PUMPEX PX 22

Pump Type	N / H
Motor rating P ₂	35 kW, 3~
Max. power input P ₁	38 kW
Voltage (V)	230 / 400 / 500 / 1000
Full load (A)	108 / 62 / 50 / 25
Speed	2930 rpm
Motor protection	Thermal overload sensors
Electric cable	20 m
Strainer passage	8 x 34 mm
Discharge connection	Hose 4" (H), 8" (N) Option: 6", G4", G6", G8"
Weight (excl. cable)	270 kg

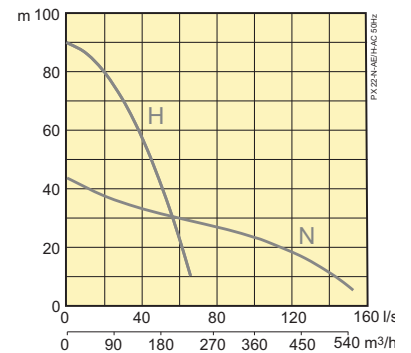
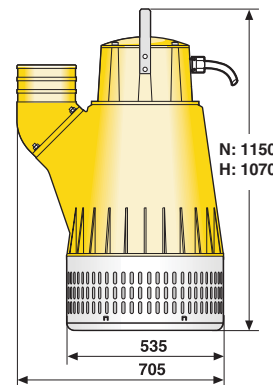

PUMPEX PX 30

Pump Type	N / H
Motor rating P ₂	56 kW, 3~
Max. power input P ₁	61 kW
Voltage (V)	230 / 400 / 500 / 1000
Full load (A)	184 / 106 / 84 / 42
Speed	1450 rpm
Motor protection	Thermal overload sensors
Electric cable	20 m
Strainer passage	12 x 60 mm
Discharge connection	Hose 6" (H), 10" (N) Option: 8", G6", G8"
Weight (excl. cable)	525 kg

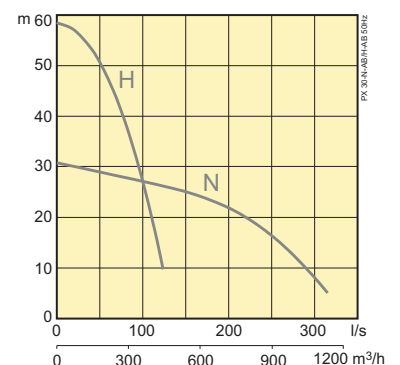
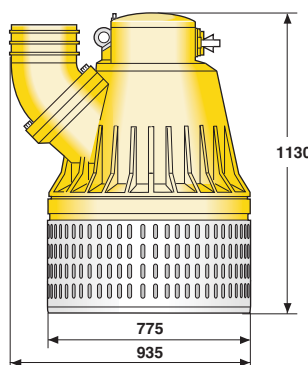

PUMPEX PC 1301

Pump Type	N / H
Motor rating P_2	3.0 kW, 3~
Max. power input P_1	3.8 kW
Voltage (V)	230 / 400 / 500
Full load (A)	12.7 / 7.3 / 5.5
Speed	2850 rpm
Motor protection	Built in
Electric cable	20 m
Strainer passage	8 x 33 mm
Discharge connection	Hose 2" (H), 3" (N) Option: G2", G3"
Weight (excl. cable)	31 kg

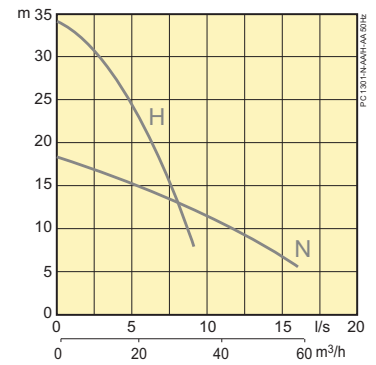
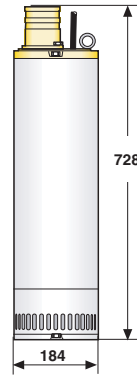

PUMPEX PSC 2000 S

Pump Type	N / V / H / N WIP* / V WIP* / H WIP*
Motor rating P_2	5.6 kW, 3~
Max. power input P_1	6.2 kW
Voltage (V)	230 / 400 / 500 / 1000
Full load (A)	19.7 / 11.3 / 9.0 / 4.5
Speed	2930 rpm
Motor protection	Built in
Electric cable	20 m
Strainer passage	7.5 x 22 mm
Discharge connection	Hose 3" (H), 4" (N), 6" (V) Option: G3", G4", G6"
Weight (excl. cable)	59 kg

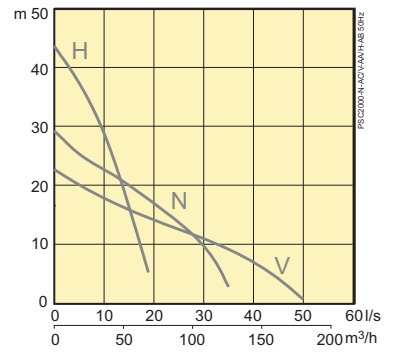
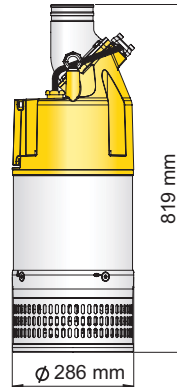

PUMPEX PSC 3000 S

Pump Type	N / V / SH / N WIP* / V WIP* / SH WIP*
Motor rating P_2	8.3 kW, 3~
Max. power input P_1	9.3 kW
Voltage (V)	230 / 400 / 500 / 1000
Full load (A)	27.8 / 16 / 12.8 / 6.4
Speed	2920 rpm
Motor protection	Built in
Electric cable	20 m
Strainer passage	7.5 x 22 mm
Discharge connection	Hose 3" (SH), 4" (N), 6" (V) Option: G3", G4", G6"
Weight (excl. cable)	63 kg (N,V), 78 kg (SH)

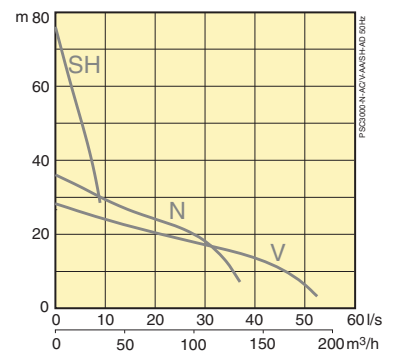
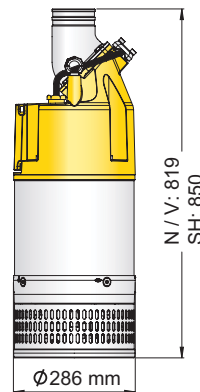

Light Duty Pump

PUMPEX GA 200

Pump Type	1-phase
Motor rating P_2	0.16 kW
Voltage (V)	230
Full load (A)	1.6
Speed	2900 rpm
Motor protection	Built in
Electric cable	10 m
Discharge connection	G1 1/4"
Weight (excl. cable)	3.8 kg

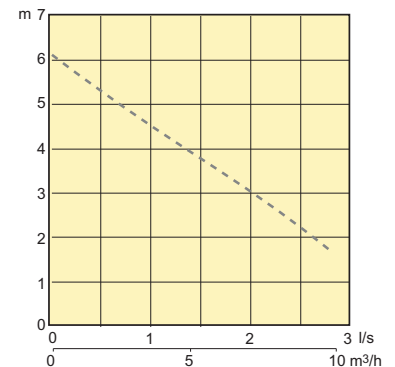
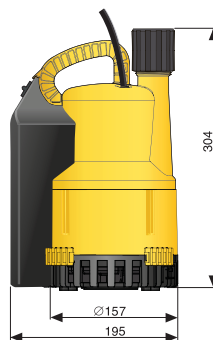

PUMPEX LIGHTWEIGHT SLUDGE PUMPS FOR HEAVY DUTY

Pumpex submersible sludge pump are excellent for pumping sludge and water mixed with solid. They have a slim design and low weight, which makes them easy to move and easy to handle. A SP or SPS pump can run without risk of overheated motor or clogged impeller. Just plug and pump!

WIP Plug -
Eliminating the need for any other starters or controls.

- Operation mode selection push-button.
- LED-illuminations to indicate operation mode.
- LED alerts for over-amperage, over-temperature, power supply problems and pump condition.

WIP Computer

- Auto stop at high amperage.
- Auto stop at high motor temp.
- Advanced auto re-start sequence in case of blocked impeller.
- Snore stop with auto start via level sensor.
- Data communication via power cable.
- Computer check of pump history, condition and data via USB connection.
- Verified maintenance with protocol.

External connection for service check and level sensor.

Double sealed, cable entry non-wicking.

Built-in starter: < 7 kW DOL-start
 > 7 kW VFC Soft Starter

Low weight by casted motor parts of lightweight aluminium alloy.

High efficiency motor, IEC2, with class H, 185 °C, insulated windings in SPS pumps. Class F, 155 °C for SP pumps.

Simplified maintenance and service by modular design and standardized spare parts.

High wear resistance by Impeller and pump housing in wear resistant ductile iron. For extreme conditions choose Pumpex stainless steel vortex impellers.

Automatic rotation correction by phase order control and dual contactors.

Over temperature protection by Bi-metal sensors in motor windings. SUPER Drainers have also NTC sensors for continuous temperature control and recording.

Easy and fast check of oil and motor through external plugs.

Environmental safe by environmentally safe white oil and non toxic coatings.

Oil over-fill protection in oil casing.

Solids handling capability and high efficiency by free flow vortex impellers and open pump.

Non overloading performance. Flexible curve selection offers (blue curve) when used in dry or snore running conditions. When half the motor or more is submersed (or when the pump is lying down) choose the maximum impeller diameter (red curve).

S Available exclusively in Pumpex SUPER Drainers, series PS, PSC and SPS.

PUMPEX SP 10 W

Pump Type

SP 10 W / WA*-2104
SP 10 W / WA*-2114

Motor rating P_2	0.9 kW, 1~
Max. power input P_1	1.2 kW
Voltage (V)	230
Full load (A)	5.1
Speed	2850 rpm
Motor protection	Built in
Electric cable	20 m
Free passage	Ø 40 mm
Discharge connection	Hose 2"

Weight (excl. cable) 18 kg
Option: 2½", 3", G2", G2½", G3"

*) Built in float switch available as option.

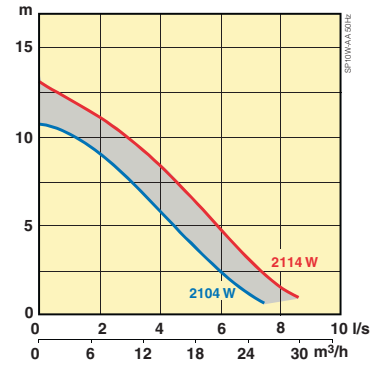
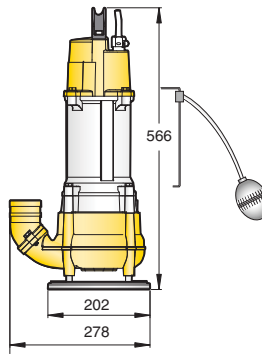

PUMPEX SP 10

Pump Type

SP 10/A*-2104
SP 10/A*-2114

Motor rating P_2	0.9 kW, 3~
Max. power input P_1	1.2 kW
Voltage (V)	230 / 400 / 500
Full load (A)	3.3 / 1.9 / 1.5
Speed	2850 rpm
Motor protection	Built in
Electric cable	20 m
Free passage	Ø 40 mm
Discharge connection	Hose 2"

Weight (excl. cable) 18 kg
Option: 2½", 3", G2", G2½", G3"

*) Built in float switch available as option, excl. 500V.

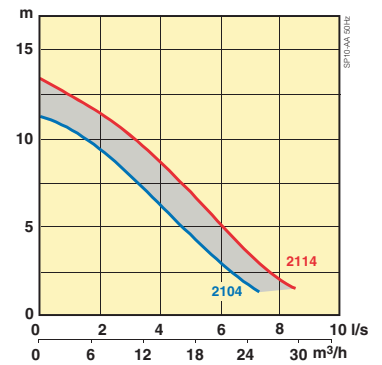
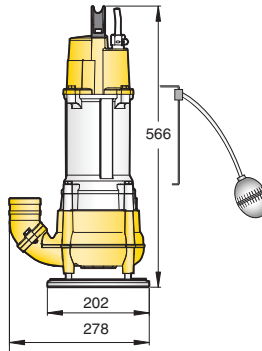

PUMPEX SP 14

Pump Type

SP 14/A*-2114
SP 14/A*-2126

Motor rating P_2	1.3 kW, 3~
Max. power input P_1	1.6 kW
Voltage (V)	230 / 400 / 500
Full load (A)	4.5 / 2.6 / 2.1
Speed	2850 rpm
Motor protection	Built in
Electric cable	20 m
Free passage	Ø 40 mm
Discharge connection	Hose 3"

Weight (excl. cable) 18 kg
Option: 2", 2½", G2", G2½", G3"

*) Built in float switch available as option, excl. 500V.

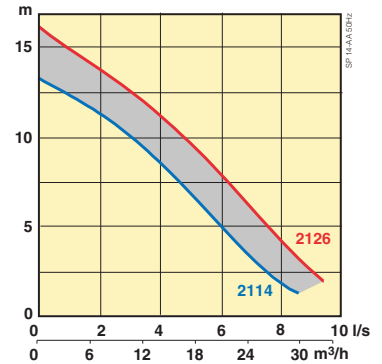
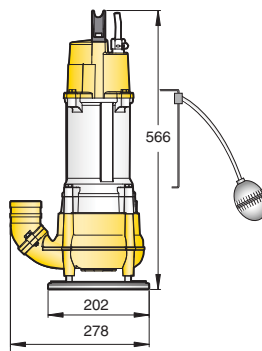

PUMPEX SPS 30 S

Pump Type

SPS 30 / SPS 30 WIP*-2128
SPS 30 / SPS 30 WIP*-2143

Motor rating P_2	2.5 kW, 3~
Max. power input P_1	2.9 kW
Voltage (V)	230 / 400 / 500 / 1000
Full load (A)	8.8 / 5.1 / 4.1 / 2.0
Speed	2920 rpm
Motor protection	Built in
Electric cable	20 m
Free passage	45 x 55 mm
Discharge connection	Hose 3"

Weight (excl. cable) 39 kg
Option: 2½", 4", G2½", G3", G4"

*WIP: Built-in WIP Computer.

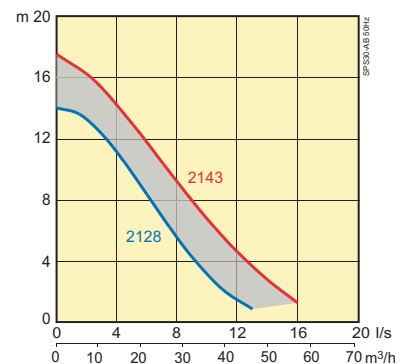
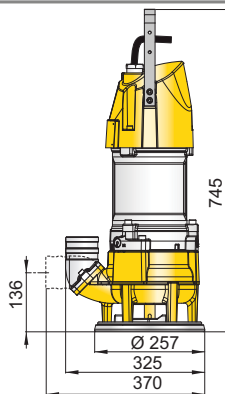

PUMPEX SPS 40 S

Pump Type

SPS 40 / SPS 40 WIP*-2143
SPS 40 / SPS 40 WIP*-2160

Motor rating P_2	3.7 kW, 3~
Max. power input P_1	4.3 kW
Voltage (V)	230 / 400 / 500 / 1000
Full load (A)	13.2 / 7.6 / 6.1 / 3.0
Speed	2860 rpm
Motor protection	Built in
Electric cable	20 m
Free passage	45 x 55 mm
Discharge connection	Hose 3"

Weight (excl. cable) 42 kg
Option: 2½", 4", G2½", G3", G4"

*WIP: Built-in WIP Computer.

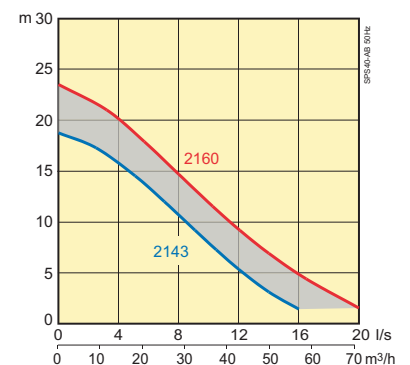
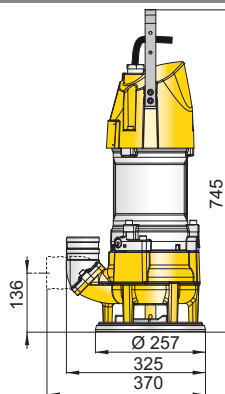

PUMPEX SPS 60 S

Pump Type

SPS 60 / SPS 60 WIP*-2160
SPS 60 / SPS 60 WIP*-2175

Motor rating P_2	5.6 kW, 3~
Max. power input P_1	6.2 kW
Voltage (V)	230 / 400 / 500 / 1000
Full load (A)	19.7 / 11.3 / 9.0 / 4.5
Speed	2930 rpm
Motor protection	Built in
Electric cable	20 m
Free passage	48 x 60 mm
Discharge connection	Hose 3"
	Option: 2½", 4", G2½", G3", G4"
Weight (excl. cable)	59 kg

*WIP: Built-in WIP Computer.

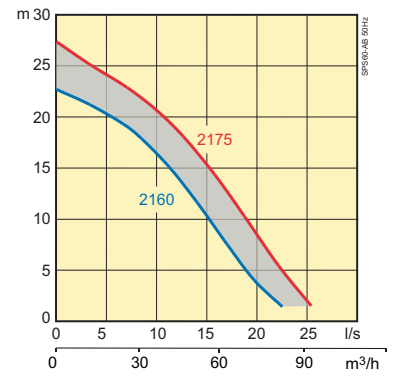
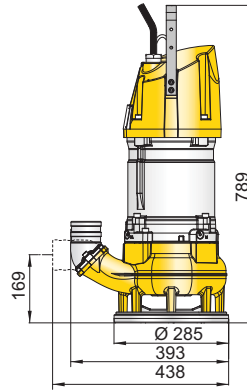

PUMPEX SPS 80 S

Pump Type

SPS 80 / SPS 80 WIP*-2175
SPS 80 / SPS 80 WIP*-2195

Motor rating P_2	8.3 kW, 3~
Max. power input P_1	9.3 kW
Voltage (V)	230 / 400 / 500 / 1000
Full load (A)	27.8 / 16 / 12.8 / 6.4
Speed	2920 rpm
Motor protection	Built in
Electric cable	20 m
Free passage	48 x 60 mm
Discharge connection	Hose 3"
	Option: 2½", 4", G2½", G3", G4"
Weight (excl. cable)	64 kg

*WIP: Built-in WIP Computer.

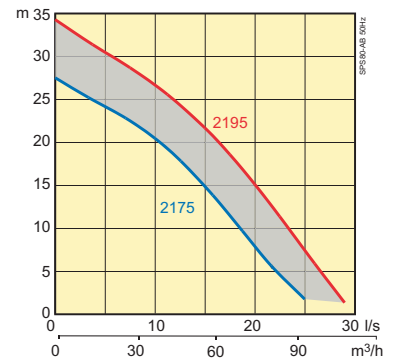
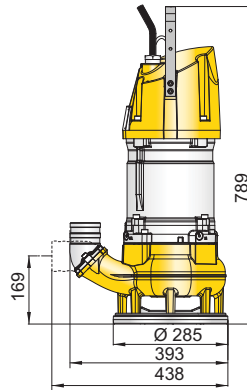

Light Duty Pump

PUMPEX KV 54-56

Pump Type

KV 54 W / WA* **KV 55 W / WA*** **KV 56 / A***

Motor rating P_2	0.7 kW, 1~	1.5 kW, 1~	1.8 kW, 3~
Max. power input P_1	1.1 kW	2.1 kW	2.4 kW
Voltage (V)	230	230	400
Full load (A)	4.8 A	9.0	4.1
Speed	2900 rpm	2900 rpm	2900 rpm
Weight (incl. cable)	14 kg	17 kg	20 kg
Motor protection	Built in		
Electric cable	10 m		
Free passage	Ø 40 mm		
Discharge connection	Hose 2" Option: G2"		

*) Built in float switch available as option.

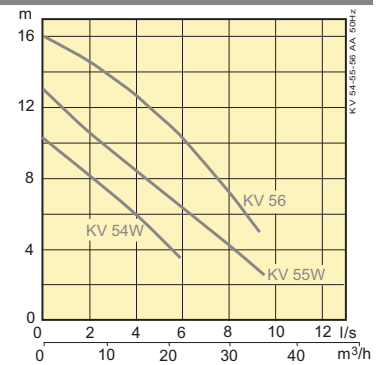
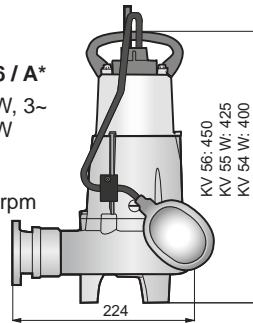

PUMP CONDITION AND SERVICE DIAGNOSTICS IN YOUR PC ^S

Data can be down loaded to any PC. No program or software is needed. Everything is stored in the WIP Computer built-into the pump.

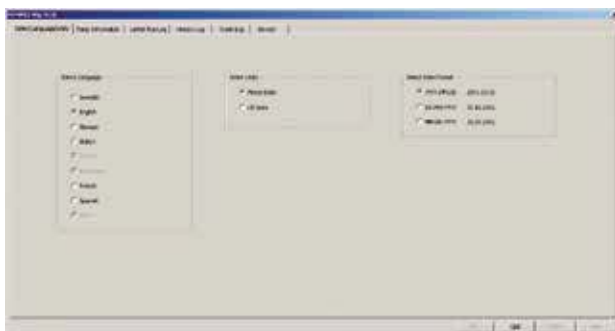
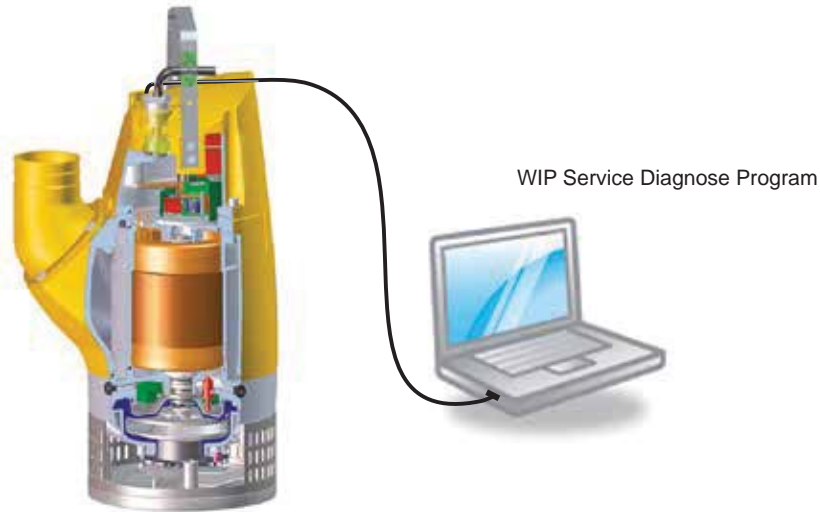

Select Language, Units and Data format

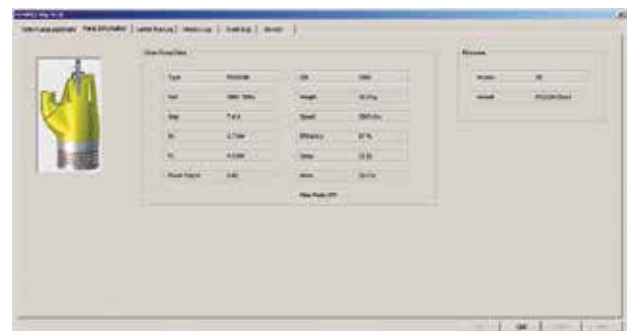

Pump information

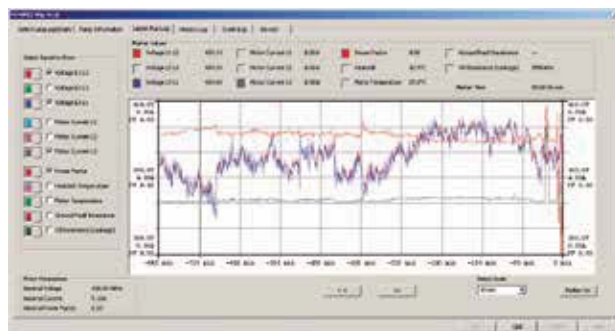

Latest run log

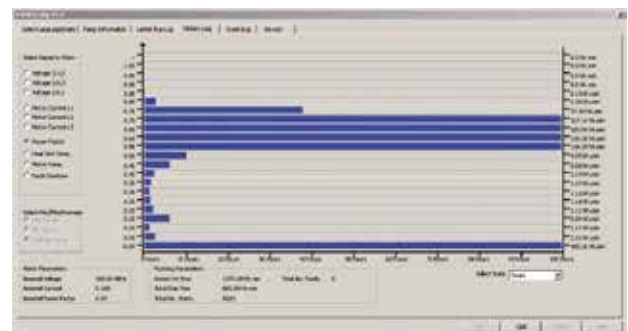

History log

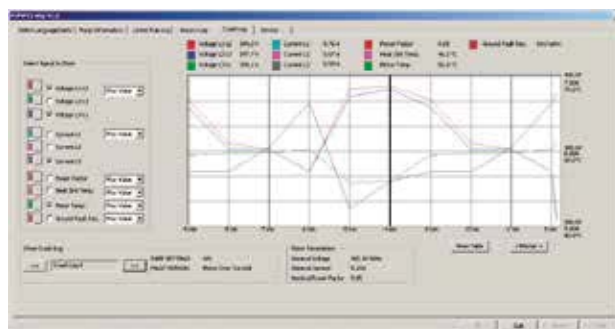

Crash log



Documentation, Service log and Update Firmware

^S Available exclusively in Pumpex SUPER Drainers, series PS, PSC and SPS.

PUMPEX TRANSPORTABLE SLUDGE PUMPS SK 81 - SK 150 FOR VERSATILE APPLICATIONS

Pumpex submersible sludge pump SK 81 - SK 150 are suitable for pumping sludge and water mixed with solid. The robust cast iron design provides a sturdy pump for rough conditions. The pump runs continuously at any water level without overheating.

Trouble free and safe handling

Pumpex sludge pump SK is a portable pump and features a sturdy stainless steel handle and a robust ductile iron stand. It can easily be lifted and moved to where it is needed without suction hoses or any concern about suction lifts. This makes installation and operation easy and safe.

Non overloading performance

All SK sludge pumps can operate over the entire performance curve without overloading the motor.

Dry running capability

Pumpex SK sludge pumps can operate with the unit totally submersed, half dry or totally dry, in continuous duty at maximum power without overheating.

Easy service and maintenance

Modular design through the complete range with interchangeable spare parts makes maintenance and service easier. The sealed cable entry is easy to access and the hydraulic parts, such as impeller, seal cartridge and volute are easy to replace, even at site.



Solids handling capability

The SK sludge pumps are fitted with free flow vortex impeller and pump housing that provides excellent non clogging performance.

High flexibility

The pump can operate in any position, vertical or horizontal.

High reliability

Pumpex SK pumps have double mechanical seals in oil bath with individual primary and secondary seals. Pumpex SK 100 and SK 150 have cartridge seal unit with double mechanical seals, silicon carbide on silicon carbide in the primary seal cooled by the closed cooling system, for long life even under the most demanding operating conditions.

The pumps are equipped with moisture sensor probe and a temperature sensor in each winding.

Rigid stainless steel shaft combined with double row angular contact ball bearings provide vibration-free operation and long pump life.

The lubricated-for-life bearing is calculated for minimum 50 000 hours service life.

Explosion proof is standard

All SK sludge pumps are explosion proof in accordance with international standards EExd IIB T4 and ATEX.

Premium efficiency motor

Pumpex SK pumps are equipped with IE3 Premium Efficiency Motors in accordance with IEC 60034-30 level IE3. The pumps have stator insulation class H and a service factor of 1.3 for extra reliability.

Environmentally safe

The oil housing on the SK 81-102 is filled with environmentally safe white oil. The oil housing on SK 100 and SK 150 is filled with environmentally safe glycol coolant.

Environmental friendly protection coatings are used on all the surfaces.

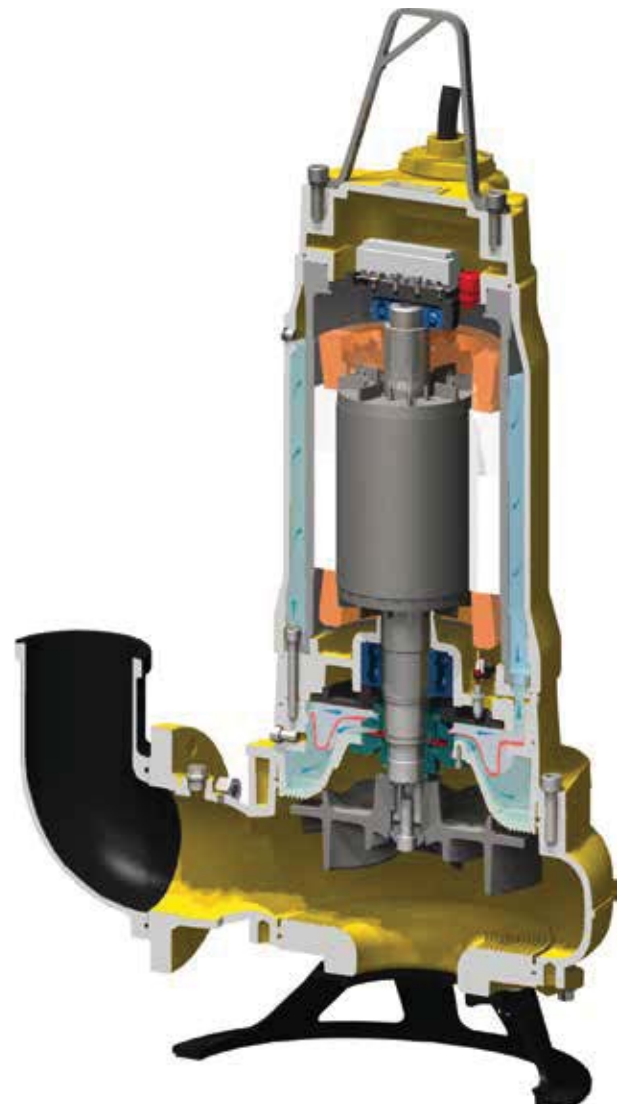

PUMPEX SK 81H-3

Pump Type	SK 81H-3
Motor rating P_2	3.0 kW, 3~
Max. power input P_1	3.42 kW
Voltage (V)	400 / 500
Full load (A)	5.6 / 4.5
Speed	2895 rpm
Weight (incl. cable)	134 kg
Motor protection	Thermal overload sensors
Electric cable	20 m
Free passage	50 mm
Discharge connection	Hose 3" Option: 4", G3", G4" Flanged DN 80

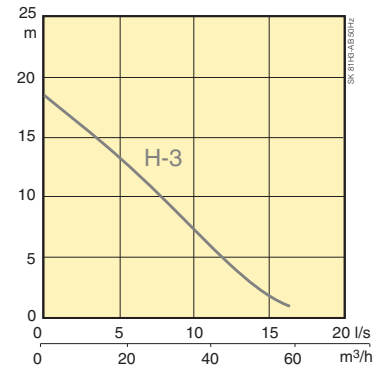
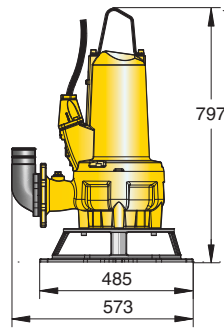

PUMPEX SK 81H-4

Pump Type	SK 81H-4
Motor rating P_2	4.0 kW, 3~
Max. power input P_1	4.52 kW
Voltage (V)	400 / 500
Full load (A)	7.4 / 5.9
Speed	2900 rpm
Weight (incl. cable)	139 kg
Motor protection	Thermal overload sensors
Electric cable	20 m
Free passage	50 mm
Discharge connection	Hose 3" Option: 4", G3", G4" Flanged DN 80

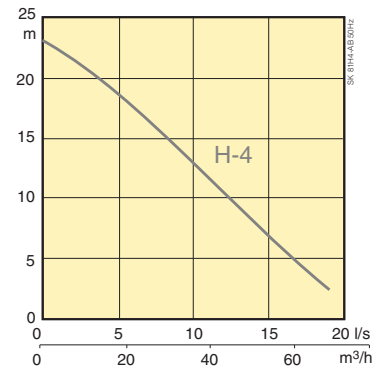
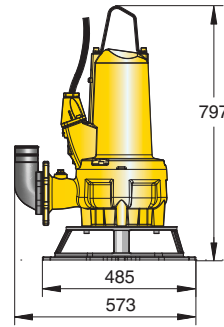

PUMPEX SK 82H

Pump Type	SK 82H-11
Motor rating P_2	11.0 kW, 3~
Max. power input P_1	12.1 kW
Voltage (V)	400 / 500
Full load (A)	20.1 / 16.1
Speed	2930 rpm
Weight (incl. cable)	166 kg
Motor protection	Thermal overload sensors
Electric cable	20 m
Free passage	65 mm
Discharge connection	Hose 4" Option: 3", G3", G4" Flanged DN 80

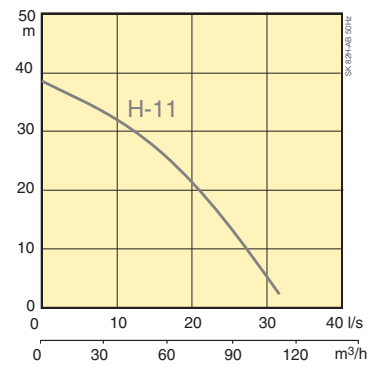
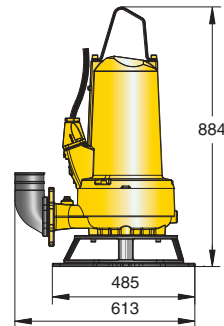

PUMPEX SK 100H-18.5

Pump Type	SK 100H-18.5
Motor rating P_2	18.5 kW, 3~
Max. power input P_1	20.0 kW
Voltage (V)	400 / 500
Full load (A)	33.7 / 27.0
Speed	2930 rpm
Weight (incl. cable)	387 kg
Motor protection	Thermal overload sensors
Electric cable	20 m
Free passage	64 mm
Discharge connection	Hose 4" Option: G4" Flanged DN 100

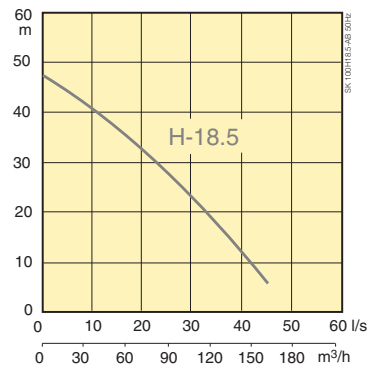
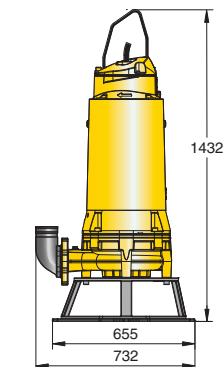

PUMPEX SK 100H-25

Pump Types	SK 100H-25
Motor rating P_2	25.0 kW, 3~
Max. power input P_1	26.9 kW
Voltage (V)	400 / 500
Full load (A)	44.0 / 35.2
Speed	2930 rpm
Weight (incl. cable)	398 kg
Motor protection	Thermal overload sensors
Electric cable	20 m
Free passage	64 mm
Discharge connection	Hose 4" Option: G4" Flanged DN 100

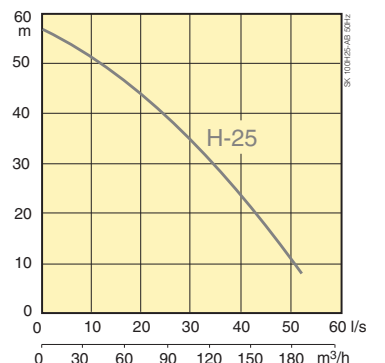
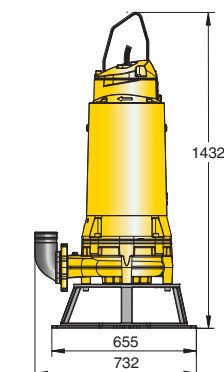

PUMPEX SK 102N

Pump Type	SK 102N-9
Motor rating P_2	9.0 kW, 3~
Max. power input P_1	9.91 kW
Voltage (V)	400 / 500
Full load (A)	18.1 / 14.5
Speed	1465 rpm
Weight (incl. cable)	180 kg
Motor protection	Thermal overload sensors
Electric cable	20 m
Free passage	100 mm
Discharge connection	Hose 4" Option: G4" Flanged DN 100

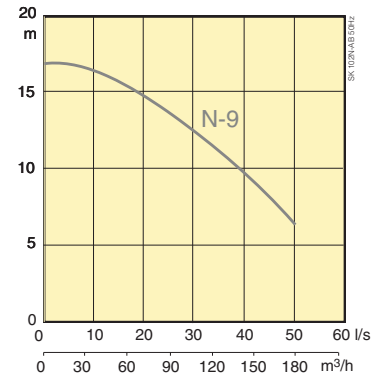
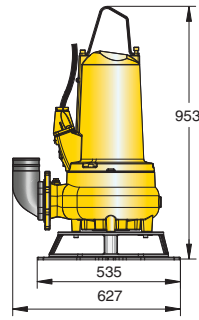

PUMPEX SK 100N

Pump Type	SK 100N-18.5
Motor rating P_2	18.5 kW, 3~
Max. power input P_1	20.0 kW
Voltage (V)	400 / 500
Full load (A)	36.9 / 29.5
Speed	1465 rpm
Weight (incl. cable)	427 kg
Motor protection	Thermal overload sensors
Electric cable	20 m
Free passage	100 mm
Discharge connection	Hose 4" Option: G4" Flanged DN 100

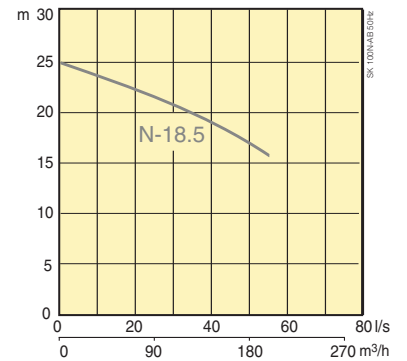
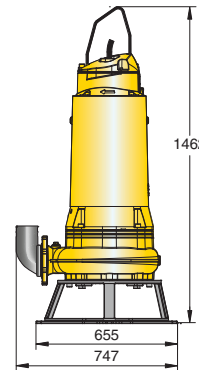

PUMPEX SK 150N

Pump Type	SK 150N-18.5
Motor rating P_2	18.5 kW, 3~
Max. power input P_1	20.0 kW
Voltage (V)	400 / 500
Full load (A)	36.9 / 29.5
Speed	1465 rpm
Weight (incl. cable)	475 kg
Motor protection	Thermal overload sensors
Electric cable	20 m
Free passage	100 mm
Discharge connection	Hose 6" Option: G6" Flanged DN 150

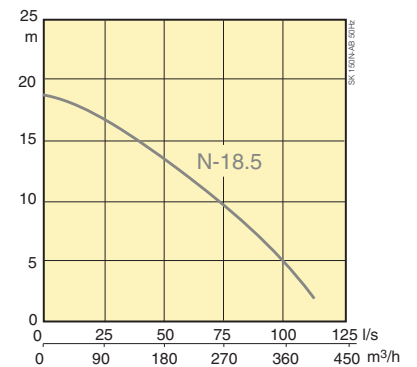
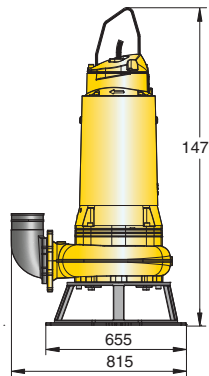

OPTIONS AND ACCESSORIES



Starters

WIP Plug S

WIP Plug is everything you need, making all other starters obsolete.

The WIP Plug, in a small, handy, watertight and robust enclosure, very easy to install between the power plug from the pump and the power supply. The WIP Plug is replacing all kind of control panels and separate starter boxes and is also offering a lot more features.

WIP Plug will automatically pair and start communicating with the WIP Computer in an unpaired SUPER Drainer when connected to the power net. Communication with the built-in WIP Computer is made through the standard power cable.

The WIP plug offers:

- Hand - Off - Auto selector switch.
- LED lamps, indicating operation mode and status.
- Power supply status, fault indications and auto stop at too much unbalance between phases or loss of a phase.
- Auto stop and indication at over-temperature in motor and/or WIP Computer, over amperage.
- Service alert in case of moisture in oil and/or in motor and low motor insulation.

The WIP Plug can only be used with a SUPER Drainer equipped with WIP Computer



Starter box DOL/Star-Delta start

Pumpex supplies also other control panels for all kind of operations, as per international standard or specially designed to meet various local requirements and specifications. If a start and stop level is required float switches can be added to the boxes.

For more detailed information contact Pumpex.

Automatic level control

PTC level sensor S

A PTC level sensor with a stainless steel rod in watertight enclosure. Easy to fix to the side of the pump and connect to the WIP Computer via the external connection at the top of the pump.

Built in float switch

P 601 110/230 V, P 801 and SP 10 230 V single-phase as well as P 601 - P 801 and SP 14 230/400 V three phase are available with built in float switch as option.

Level control can also be obtained by a float switch connected to an external control / starter.

A typical installation for automatic level control is in narrow sumps where the level of the sump is changing quickly or in other installations to reduce excess wear and power consumption by avoiding that the pump is working on snore, without water.





SoftDrive™

SUPER Drainers have built-in SoftDrive as standard for all pumps above 7 kW.

SoftDrive™ is also available as option built in on PX 12. The Pumpex SoftDrive™ concept reduces starting current dramatically, providing a smooth operation for both the power net and pump equipment. Eliminates water hammering effects when the pump is stopped, allowing the pump to smoothly ramp down. Intelligent protection built into the pump, ensuring correct impeller rotation, motor protection and main power check at start up.

Electronic motor supervision

FSV 82, electronic motor protector is available for PX 12 and PX 22. FSV motor protector prevents the pump from starting in the wrong direction of rotation. This protection device will also trip the pump in event of phase failure.

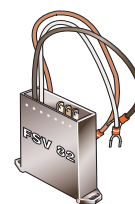

PC communication kit **S**

Data cable to connect a SUPER Drainer with built-in WIP Computer, to a USB port in a PC, to read / transfer data from the WIP Computer such as, technical data, service instructions, spare parts information, pump condition, operation history, read crash log, service history etc.



Surface protection coating

For improved corrosion resistance Pumpex offers a special surface protection with an extra layer of Pumpex environmental friendly 2-component epoxy coating on all casted parts.

For extreme conditions zinc anodes, ZincPro™, can be added to the 2-component epoxy coating.

ZincPro™

Pumpex ZincPro™, a zinc protection system can be used on all Pumpex submersible dewatering pumps, an easy way to extend the service life of pumps in salty water. Mounting sacrificing anodes of zinc to the pump body is a well proven method to reduce galvanic corrosion of aluminium castings when used in salty water. The method has been used for many years not only for submersible pumps but also to protect other machines such as outboard motors for leisure boats.

Pumpex ZincPro™ belts are very easy to fit to the pump as well as to replace when needed.

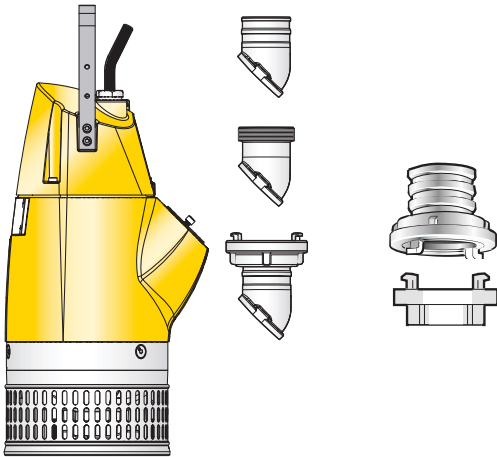

Discharge connections

Pumpex dewatering pumps are available with a variety of discharge types and different sizes for each pump model.

Plain discharge to fit the discharge hose direct to the pump with one or two hose clamps.

Discharge with external thread, as per BSP or NPT standards, for use together with different types of standard couplings for hose or pipe connections.

Storz quick connections coupling, in aluminium, can be supplied as option, to be used together with a threaded pump discharge.

Storz couplings are available in following sizes:

2" (type C), 3" (type B), 4" (type A) and 6" (type F)



Emergency kit

Pumpex emergency kit including pump, discharge connection, hose, hose clamps, lifting rope and extra accessory for low level pumping. The complete kit is lifted off a truck and brought to where it is needed. For emergency situations all equipment are on site for a fast, easy and safe installation. When pumping is ended it is easy to put parts back in the support case and bring it back to the truck or to the next site.



Polyurethane

Pumpex offers Enduro Lining™, a solution where the diffusers and wear discs are coated with polyurethane.

Pumpex impellers are designed with a full upper shroud, which improves the wear resistance of the impeller and eliminates the need of polyurethane on the oil casing cover.



Polyurethane coated wear parts are mainly used in extremely abrasive applications such as in mining.

Stainless steel impellers

Pumpex also offers stainless steel impellers for SPS pumps and a selected range of PX pumps.



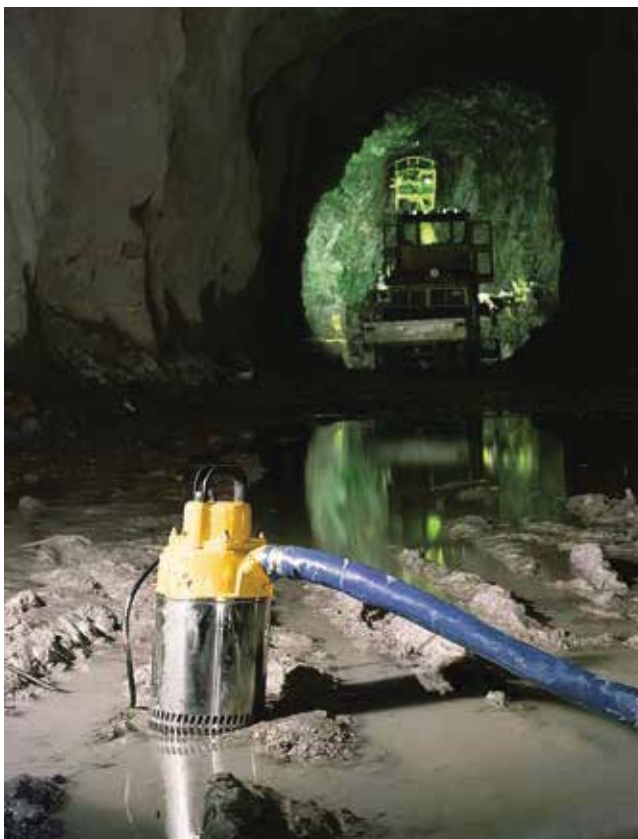

Series connection

Series connections are available for all drainage pumps. The series connections have a centre inlet for hose connection.

Bottom suction adapter

On pumps series P 601 and P 801 the standard bottom plate may be replaced by a bottom suction adapter. A basement floor or a tank can then be pumped practically dry.

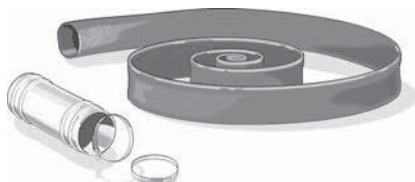
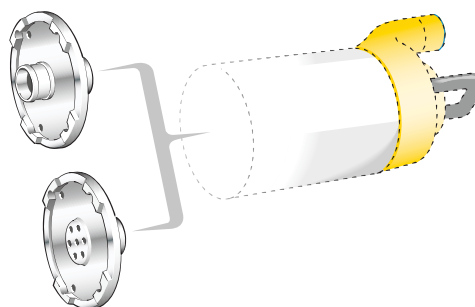

Hose, jointing pipe, clamp

Flexible reinforced discharge hose.

Available with inner diameter 1", 1 1/2", 2", 2 1/2", 3", 4", 6", 8".

Hose clamp and jointing pipe for flexible hose are available with same diameter.



PumpFloater™

Pumpex PumpFloater™ offers a modular system and cover pumps from 18 to 600 kg.

The PumpFloater™ is easy to use and build to any of Pumpex dewatering pumps. Other pump types may be used after checking the lifting capacity.

The flexible design makes it easy to simply add on another floatation module to increase the floating capacity.

The length of the 2 part lifting chain is easily adjusted for the pump to be installed in the water correctly.



**Our products are being exported to more than
70 countries, all over the world.**

The manufacturer reserves the right to alter performance, specifications or design without notice.
P_PS_SP_SPS.GB50.2013.10 © Copyright (2013) Pumpex

WWW.PUMPEX.COM

PUMPEX SALES
Rökerigatan 20
SE-121 62 JOHANNESHOV
Sweden
com

Tel: +46 10 130 1809
Fax: +46 8 659 33 14
E-mail: info@pumpex.com



PUMPEX PRODUCTION
Åsgatan 3
SE-914 32 NORDMALING
Sweden

Tel: +46 10 130 1700
Fax: +46 930 100 57
E-mail: info@pumpex.com

