

# TM Series Drum Mixer



FINISH THOMPSON INC.

## Sealed, Light/Medium Viscosity

Sealed mixer with 4-blade turbine mixing/blending capability. Ideal for rapid suspension of settled solids.

- Features:** 316SS tube construction  
 Top-to-bottom mixing action  
 Tube interchangeable with motors  
 Up to 1000 cP with electric or air motor

**Applications:** Dyes, inks, paints, stains, mild corrosives, solvents\*, flammables

**TMS**



**Tube Length**  
40" (102cm)

### Construction Specifications

Model	Construction Materials		Tube Dia. in (cm)	Max. Temp.		Min. Temp.	
	Outer Tube	Internals		°F	°C	°F	°C
TMS	316 Stainless Steel	316 Stainless Steel, PTFE	2 (5.1)	200	93	-20	-29

Consult FTI's Chemical Resistance Chart (<http://www.finishthompson.com/downloads/drum-pumps/technical-flyers>) before selecting pump material.

### Performance Data

Maximum Circulation	Maximum Specific Gravity	Maximum Viscosity
14 gpm (53 lpm)	1.8	1,000 cP

- *Top-to-bottom mixing action allows rapid suspension of settled solids.*
- *Pulls lighter liquid from top and discharges under pressure out the bottom of the mixer tube.*



\*When mixing flammables or combustibles, use explosion proof electric or air drive motors on stainless steel tubes with static protection kit.

Need help choosing a pump?  
 Use the handy online Pump Selector at:  
[www.finishthompson.com](http://www.finishthompson.com).



## MOTOR DATA



**TEFC**  
(M7T, M8T)



**Exp-Proof**  
(M7X)



**Air**  
(M6, M6X)

Model	Description	Type	Certification	Electrical Requirements	Power		RPM
					HP	W	
<b>TEFC (Totally Enclosed Fan Cooled), IP54 Motors</b>							
M7T	Continuous duty. 12 ft. (3.5 m) cord w/ NEMA 5-15 Type B plug and circuit breaker w/ manual reset.	Induction	CSA	115VAC/50-60 Hz	2/3	500	2850/3450
M8T	Continuous duty. 12 ft. (3.5 m) cord.		CE	230VAC/50-60 Hz	2/3	500	2850/3450
<b>Explosion Proof Motors</b>							
M7X	Suitable for use in hazardous areas, ideal for flammable liquids. TEFC housing. 12ft. (3.5m) cord, internal circuit breaker. Continuous duty.	TEFC, Ex-proof	CSA	115VAC/50-60 Hz	2/3	500	2850/3450
<b>Air Motors<sup>†‡</sup></b>							
M6	Lightweight. Operates from customer-supplied compressed air source. Variable speed. Muffler and control valve.	Air	CE	80-100 psi @ 15-32 cfm	1/2	370	300-9,000
M6X			CE	80-100 psi @ 15-32 cfm	3/4	560	300-6,000

<sup>†</sup>An air motor is a non-electrical device meaning possibility of explosion from igniting flammables/combustibles is reduced. Air motor performance will depend upon user's system setup.

<sup>‡</sup>Motor suitable for hazardous areas that do not require independent certification.

### Dimensions

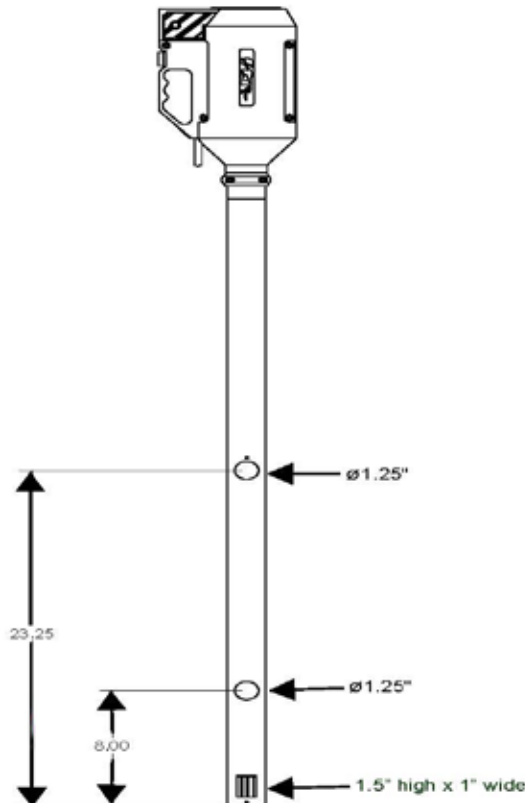

### Accessories

#### Drum Adapters



#### Static Protection Kit



#### Air Hose Assembly



#### Filter Lubricator Assembly

