

OVERVIEW

The WBL/WDB400 Boiler Controllers and WCM/WDC400 Condensate Monitors represent the latest in technological and innovative advancements from Walchem. All of the standard features you'd expect in conventional boiler controllers/condensate monitors are included, plus optional simple-to-use information management tools that enable water treatment professionals to deliver more effective service to their customers.

The 400 Boiler Controllers and Condensate Monitors have the ability to store conductivity and temperature values, water usage, relay status, and user settings. A USB memory stick is all that's needed to extract the information. Download logs from the USB stick to a PC at your convenience, or copy your preferred treatment program settings to another controller to speed start-up. It couldn't be easier!



SUMMARY OF KEY BENEFITS

- Ensures Optimal Performance and Maximum Efficiency**
Precise control of conductivity and chemical feed inhibits corrosion, solids precipitation and scale build-up. Unique time proportional blowdown feature saves energy by reducing water consumption.

- More Informative Monthly Reports**
Download stored data from the controller to a USB flash stick. Use the data to easily develop reports that show actual water usage, system conductivity, temperature, and more.

- Efficient Customer Service**
Quickly identify system upsets by knowing exactly what happened and when. An event log can be downloaded to tell you precisely when pumps turned on, valves opened and when the boiler was offline.

- Validation and Verification Made Easy**
Use stored data from the controller to simply and easily validate water treatment results. The data and event logs show water usage, system conductivity, and temperature, as well as accumulated chemical feed and blow-down times.

- Save Time**
Copy the user settings from your controller to a USB flash stick and upload to a new controller. Programming your new controller this way can be accomplished in seconds. It's that simple!



Boiler Conductivity Controllers / Boiler Condensate Monitors

» Choice of measurement units

- To customize your control or complement your calibration procedures, conductivity may be displayed as μS or PPM; temperature as $^{\circ}\text{F}$ or $^{\circ}\text{C}$.

» Four chemical feed options

- Feed & blowdown simultaneously, with or without feed lockout timer
- Feed after blowdown has finished, as a percentage of blowdown time
- Feed as a percentage of time elapsed
- Feed as a percentage of make-up water

» Detects flashing during timed samples

- Rechecks the conductivity after the sample valve closes and reopens if the reading is now above set point.

» Self-diagnostics

- Software, electronics and sensor are constantly monitored, without having to take the controllers off-line.

» Choices of blowdown modes for timed samples

- In intermittent sampling, the blowdown valve is open until the set point conductivity is reached.
- In intermittent with timed blowdown, the blowdown valve opens for a set programmable time.
- In intermittent with time proportional blowdown, the blowdown valve opens for a variable time that is calculated based on the conductivity of the sample versus the set point.

» Automatic temperature compensation

- Conductivity measurements are temperature compensated to ensure the highest accuracy.

» USB Flashstick Support

- Standard for data logs, event/relay and reset logs, and user configuration file import/export

USB Features

Integrated datalogging collects analytical measurements at 10 minute intervals and captures all relay activations.

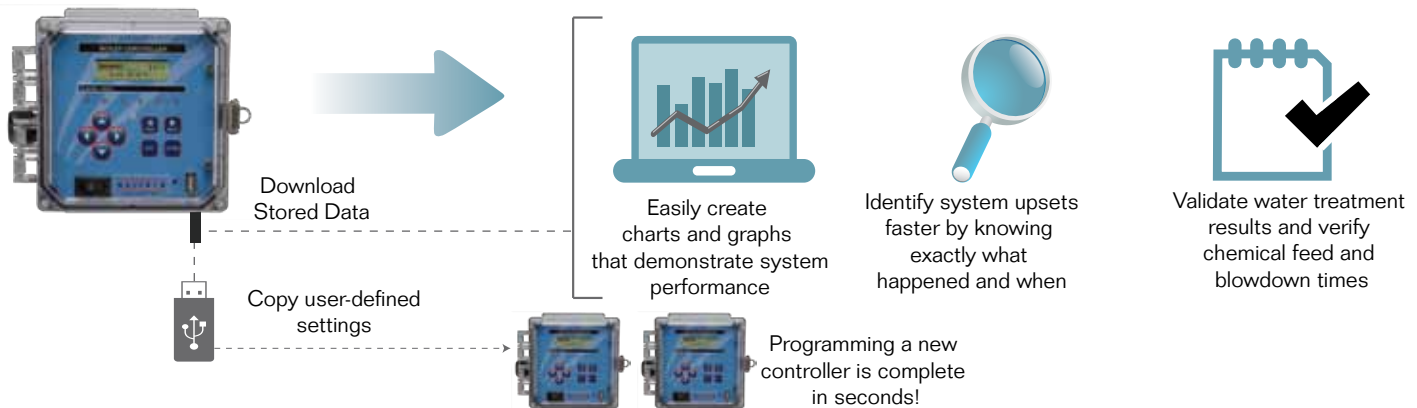

Time Proportional Control

Walchem offers a unique time proportional control algorithm for timed (intermittent) sampling. This algorithm allows the controller to measure the conductivity of the boiler water sample with the control valve closed (which eliminates flashing problems). After getting an accurate reading of the conductivity, the controller performs a timed blowdown that will vary in its duration, extending the blowdown time as the conductivity moves further from the set point.

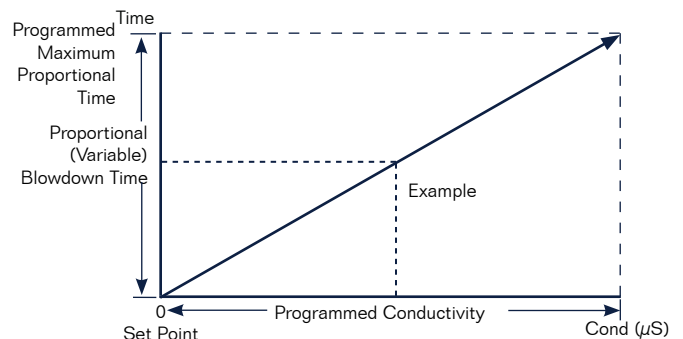

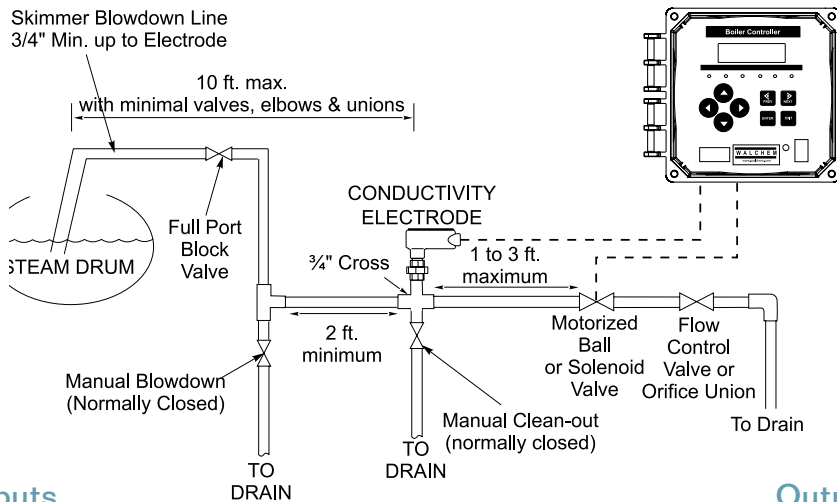

Typical Installation for Intermittent Sampling

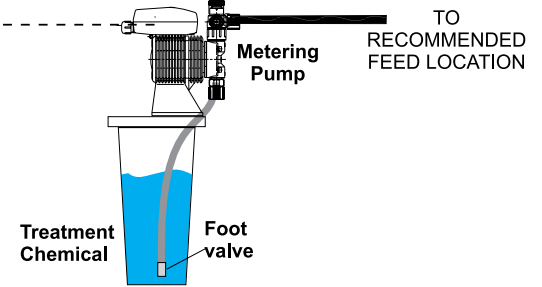

Inputs

Power

100-240 VAC, 50/60 Hz, 8A
Fuse: 1.0 ampere, 5 x 20 mm

Signals

Cond Electrode: 1.0 cell factor, 10K thermistor
Flow Meter (optional): Isolated, dry contact closure required (i.e. relay, reed switch)
Flow Switch (optional): Isolated, dry contact closure required (i.e. reed switch)

	Cond Electrodes	Flow switch inputs	Flow meter inputs
WBL	1	1	2
WCM	1	1	
WDB	2	2	2
WDC	2	2	

Mechanical

Enclosure: Polycarbonate
NEMA Rating: NEMA 4X (IP65)
Display: 2 x 16 character backlit liquid crystal
Ambient Temperature: 32 to 122°F (0 to 50°C)
Storage Temperature: -20 to +180°F (-29 to +80°C)
Shipping weight: 7 lbs (3 kg) (approximately)
Electrode Mounting: 3/4" NPTM
Electrode Rating: 250 psi @ 392°F (17.2 bars at 200°C)
Electrode Material: 316 SS and PEEK

Controller Dimensions

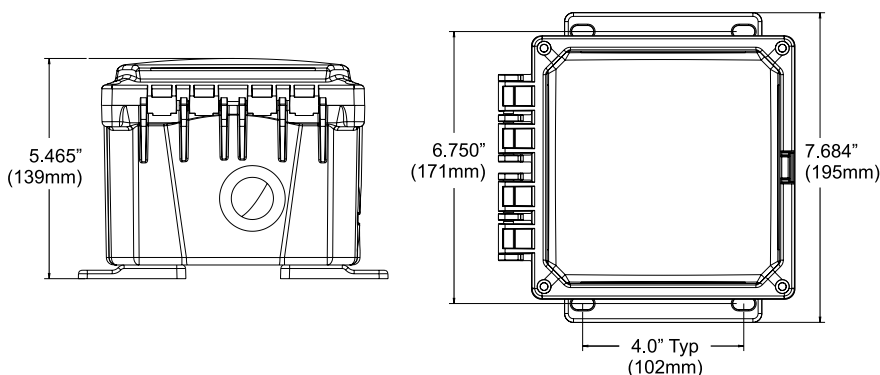

Outputs

Mechanical Relays

WBL400: Two powered relays (Blowdown & Feed)
WBL410: Six powered relays (Blowdown, 4 Feed/Alarm, 1 Dedicated Alarm)
WCM: Two powered relays (Divert & Alarm)
WDB: 5 powered relays (Blowdown & Feed for each system, 1 Dedicated Alarm)
WDC: 5 powered relays (Divert & Alarm for each system, 1 dedicated Alarm)

6 A (resistive), 1/8 HP

All relays are fused together as one group, total current for this group must not exceed 6A

4 - 20 mA (optional)

Internally powered
Fully isolated
600 Ohm max resistive load
Resolution .001% of span
Accuracy $\pm 1\%$ of reading

Measurement Performance

Conductivity Range: 0-10,000 $\mu\text{S}/\text{cm}$
Resolution: 1 μS
Accuracy: 10-10,000 $\mu\text{S}/\text{cm} \pm 1\%$ of reading
10-10 $\mu\text{S}/\text{cm} \pm 20\%$ of reading
Temperature Range: 32 to 392°F (0 to 200°C)
Resolution: 0.1° C
Accuracy: $\pm 1\%$ of reading

Sensor Dimensions

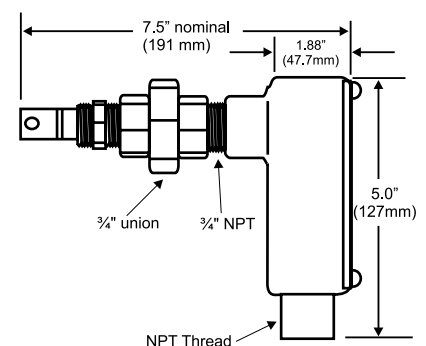

ORDER INFORMATION

WBL4 0 — U
control voltage output sensor USB

WCM400
WDB400 — U
WDC400 voltage output sensor USB

CONTROL

0 = Two (2) powered relays
1 = Six (6) powered relays

VOLTAGE

1 = 120 VAC, prewired
5 = 100-240 VAC, conduit

OUTPUT

N = No data output
4 = Isolated 4-20 mA output
2 = Two isolated 4-20 mA outputs

SENSOR

N = No electrode
5 = Standard electrode (up to 250 psi)

USB FEATURES

U = Integrated datalogging, event/reset logging, and configuration file import/export

AGENCY CERTIFICATIONS

UL	ANSI/UL 61010-1:2004, 2nd Edition*
CAN/CSA	C22,2 No.61010-1:2004 2nd Edition*
CE Safety	EN 61010-1:2001 2nd Edition*
CE EMC	EN 61326-1:2006

Note: For EN61000-4-6 & EN61000-4-3 the controller met performance criteria B.

*Class A equipment: Equipment suitable for use in establishments other than domestic, and those directly connected to a low voltage (100-240 VAC) power supply network which supplies buildings used for domestic purposes.



Webmaster®ONE

WebMasterONE is the most advanced online cooling tower and boiler controller in the water treatment industry. The flexible multi-I/O platform allows you to control multiple cooling towers, boilers, closed loops, and condensate lines with just one controller. An extensive assortment of integrated communications and data handling features are included that enable water treatment professionals to provide more effective water management services to their customers.



Metering Pumps

The E-Class is the most innovative and comprehensive metering pump product line in the world. Over 50 years of pump experience and a commitment to superior mechanical design has led to development of many industry firsts, including 360 stroke-per-minute technology, IP67 waterproof construction, and the world's highest capacity solenoid metering pumps.



WIND WebMaster Industrial Water Controllers

Walchem's WebMaster® Industrial (WIND) Controller sets a new standard for Industrial Water Treatment Controllers. WIND has a flexible multi-I/O platform, a wide range of analytical sensor measurement capabilities, and an extensive assortment of integrated communications and data handling features.



WebAlert Remote Monitor

Walchem's WebAlert is the first stand alone remote monitoring device that can web enable your installed equipment without having to replace or upgrade it.

ABOUT US

Walchem integrates its advanced sensing, instrumentation, fluid pumping and communications technologies to deliver reliable and innovative solutions to the global water treatment market

Our in-house engineering is driven by quality, technology and innovation. For more information on the entire Walchem product line, visit: www.walchem.com

WALCHEM
An Iwaki America Company

Walchem, An Iwaki America Incorporated Company
Five Boynton Road Hopping Brook Park
Holliston, MA 01746 USA
Phone: 508-429-1110
Fax: 508-429-7433
www.walchem.com