



Enriching Lives

## END SUCTION PUMPS

*TYPE - DB*



CE

**KIRLOSKAR BROTHERS LIMITED**

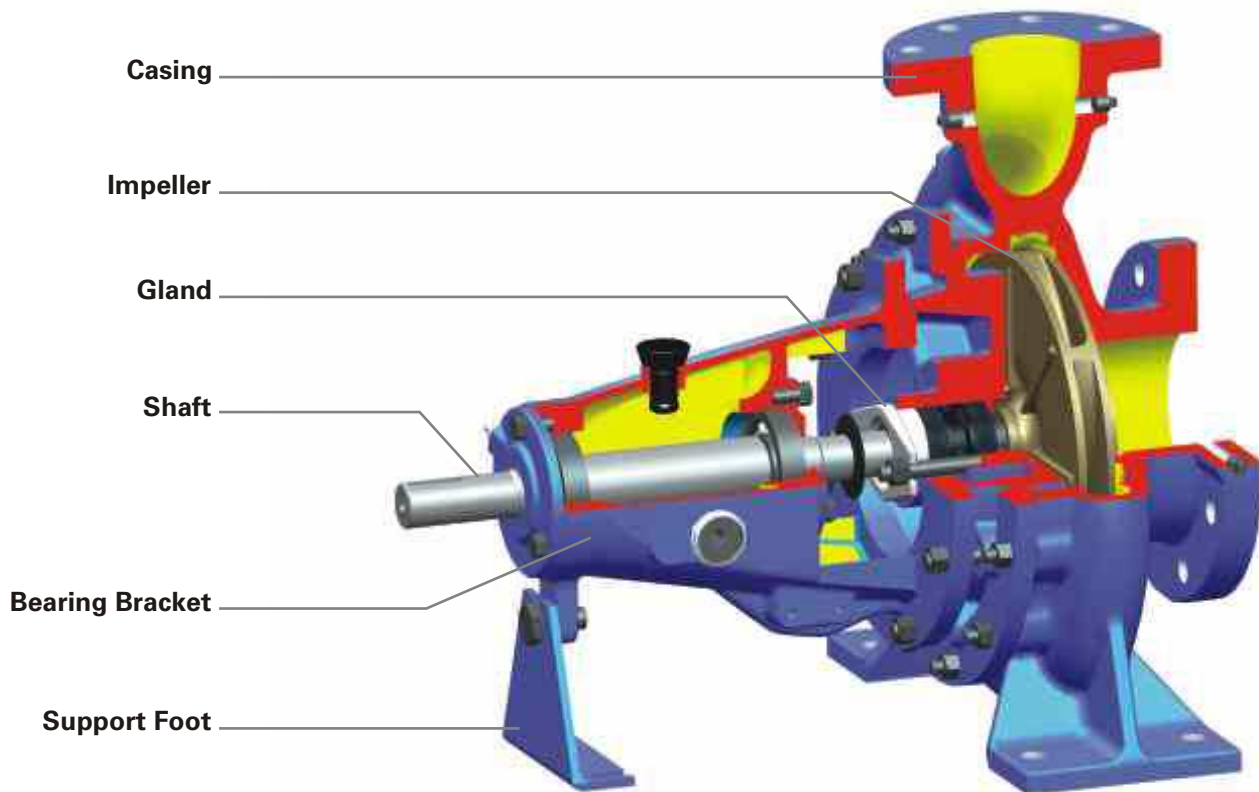

## RANGE

*Delivery size* : up to 150 mm  
*Capacity* : up to 550 m<sup>3</sup>/hr  
*Head* : up to 100 metres

## APPLICATIONS

*Circulation of water in industries, Air-conditioning plants, Power stations, Mine water, Lift irrigation, Sprinkler systems, Fire fighting, Booster services, Pumping brines, Oils etc. for liquids having temperature in the range of -10°C to 100°C.*

## FEATURES

*These are single stage, single suction, horizontal shaft type. They are made in accordance with DIN 24255. Models are available to operate at 1450 rpm and 2900 rpm at 50 Hz*

### **Casing :**

*End suction, volute type with top centreline discharge. Suction and discharge nozzles as well as the supporting feet are cast integral with the casing.*

### **Impeller :**

*Enclosed type dynamically balanced. Hydraulic balance is achieved either by back vanes for smaller impellers and by balancing hole with back wear rings for large impellers.*

### **Shaft :**

*Three driving units cover complete range. The high tensile steel shaft accurately machined and ground is supported by anti-friction bearings. The shaft is protected by shaft sleeve from wear in stuffing box area.*

### **Stuffing Box :**

*The stuffing box can be sealed by gland packing or by mechanical seal.*

### **Bearing :**

*Deep groove ball bearings are provided. Standard lubrication is grease. Oil lubrication against requirement.*

### **Direction of Rotation :**

*Clockwise viewed from driving end.*

### **Drive :**

*Suitable for coupling with electric motors, engines directly or through belt drives.*

### **Flanges :**

*Standard : Drilling as per BS EN 1092-2 (DIN 2533 ND 16)*

*Optional : Drilling as per IS/BS/ASA/DIN available with suitable pressure rating.*

# GENERAL DIMENSIONS / MOUNTING DETAILS

## Outline Drawing

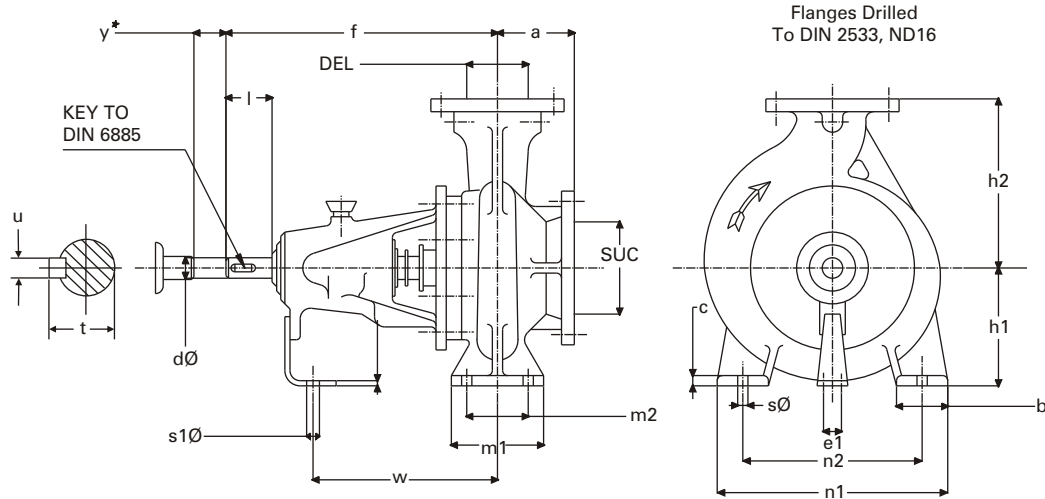

PUMP MODEL	UNIT NO.	SUC.	DEL.	PUMP MOUNTING DIMENSIONS														SHAFT END					WT. KG
				a	f	h1	h2	b	c	m1	m2	n1	n2	sØ	e1	sØ	w	dØ	l	t	u	y	
32/13	25	50	32	80	360	112	140	50	14	100	70	190	140	14	100	14	267	24	50	27	8	100	28
32/16	25	50	32	80	360	132	160	50	14	100	70	240	190	14	100	14	267	24	50	27	8	100	34
32/20	25	50	32	80	360	160	180	50	14	100	70	240	190	14	110	14	267	24	50	27	8	100	41
32/26	25	50	32	100	360	180	225	65	14	125	95	320	250	14	110	14	267	24	50	27	8	100	59
40/13	25	65	40	80	360	112	140	50	14	100	70	210	160	14	100	14	267	24	50	27	8	100	29
40/16	25	65	40	80	360	132	160	50	14	100	70	240	190	14	100	14	267	24	50	27	8	100	36
40/20	25	65	40	100	360	160	180	50	14	100	70	265	212	14	110	14	267	24	50	27	8	100	44
40/26	25	65	40	100	360	180	225	65	14	125	95	320	250	14	110	14	267	24	50	27	8	100	61
50/13	25	65	50	100	360	132	160	50	14	100	70	240	190	14	100	14	267	24	50	27	8	100	32
50/16	25	65	50	100	360	160	180	50	14	100	70	265	212	14	110	14	267	24	50	27	8	100	38
50/20	25	65	50	100	360	160	200	50	14	100	70	265	212	14	110	14	267	24	50	27	8	100	46
50/26	25	65	50	100	360	180	225	65	14	125	95	320	250	14	110	14	267	24	50	27	8	100	63
50/32K	35	65	50	125	470	225	290	80	16	160	120	400	315	18	110	14	342	32	80	35	10	140	83
65/13	25	80	65	100	360	160	180	65	14	125	95	280	212	14	110	14	267	24	50	27	8	100	39
65/16	25	80	65	100	360	160	200	65	14	125	95	280	212	14	110	14	267	24	50	27	8	100	43
65/20	25	80	65	100	360	180	225	65	14	125	95	320	250	14	110	14	267	24	50	27	8	100	52
65/26	35	80	65	100	470	200	250	80	16	160	120	360	280	18	110	14	342	32	80	35	10	140	81
65/32	35	80	65	125	470	225	280	80	16	160	120	400	315	18	110	14	342	32	80	35	10	140	100
80/16	25	100	80	125	360	180	225	65	14	125	95	320	250	14	110	14	267	24	50	27	8	100	53
80/20	35	100	80	125	470	180	250	65	14	125	95	345	280	14	110	14	342	32	80	35	10	140	70
80/26	35	100	80	125	470	200	280	80	16	160	120	400	315	18	110	14	342	32	80	35	10	140	91
80/32	35	100	80	125	470	250	315	80	16	160	120	400	315	18	110	14	342	32	80	35	10	140	107
100/20	35	125	100	125	470	200	280	80	16	160	120	360	280	18	110	14	342	32	80	35	10	140	85
100/26	35	125	100	140	470	225	280	80	16	160	120	400	315	18	110	14	342	32	80	35	10	140	103
100/32	35	125	100	140	470	250	315	80	16	160	120	400	315	18	110	14	342	32	80	35	10	140	116
100/40	45	125	10	140	530	280	355	100	18	200	150	500	400	23	110	14	370	42	110	45	12	140	177
125/26	35	150	125	140	470	250	355	80	16	160	120	400	315	18	110	14	342	32	80	35	10	140	110
125/32	45	150	125	140	530	280	355	100	18	200	150	500	400	23	110	14	370	42	110	45	12	140	151
125/40	45	150	125	140	530	315	400	100	18	200	150	500	400	23	110	14	370	42	110	45	12	140	188
150/32	45	200	150	160	530	280	400	100	18	200	150	550	450	23	110	14	370	42	110	45	12	140	170
150/40	45	200	150	160	530	315	450	100	18	200	150	550	450	23	110	14	370	42	110	45	12	140	205

\*Y - Backpullout distance required between motor shaft end and pump shaft  
All Dimensions are in mm

# CROSS-SECTION VIEW

## DB Pump

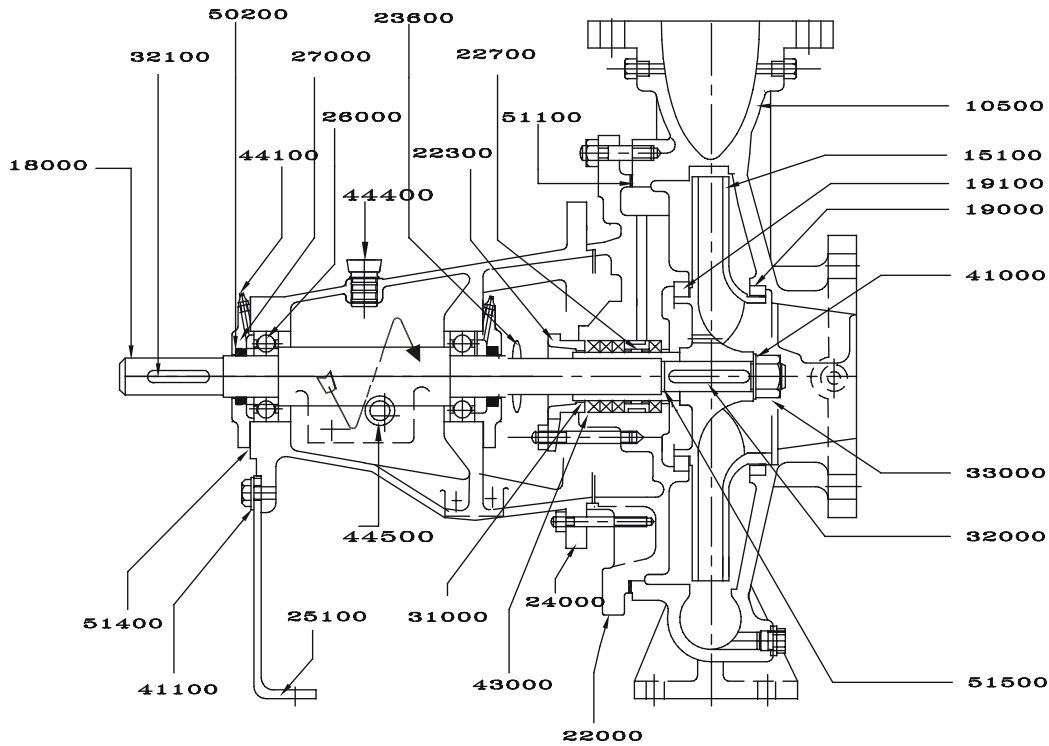

## INTERCHANGEABILITY OF COMPONENTS

PART NO.	NAME OF PART	TOTAL NO.OF PARTS	PUMP MODEL																															
			32/13	40/13	50/13	65/13	32/16	40/16	50/16	65/16	80/16	32/20	40/20	50/20	65/20	32/26	40/26	50/26	80/20	100/20	65/26	80/26	100/26	125/26	50/32K	65/32	80/32	100/32	125/32	150/32	100/40	125/40	150/40	
			UNIT 25															UNIT 35										UNIT 45						
10500	PUMP CASING	31	1	2	3	4	5	6	7	8	9	10	11	12	13	14	15	16	17	18	19	20	21	22	32	23	24	25	26	27	28	29	30	
15100	IMPELLER	31	1	2	3	4	5	6	7	8	9	10	11	12	13	14	15	16	17	18	19	20	21	22	32	23	24	25	26	27	28	29	30	
18000	SHAFT	3									1											2												
19000	CASING RING	10	1	2	3	4	1	2	3	4	5	2	2	3	4	2	3	4	5	6	4	5	6	7	15	5	8	6	7	9	6	7	9	
22000	CASING COVER	10	1	1	1	1	2	2	2	2	2	3	3	3	3	4	4	4	5	5	6	6	7	7	8	8	8	8	9	9	10	10	10	
22300	GLAND	3									1											2											3	
22700	LANTERN RING	3									1											2											3	
24000	BEARING HOUSING	4	1	1	1	1	2	2	2	2	2	1	1	1	1	2	2	2	3	3	3	3	3	3	3	3	3	3	3	4	4	4	4	4
25100	SUPPORT FOOT	8	1	1	2	3	2	2	3	3	4	3	3	3	4	4	4	4	3	4	4	4	5	6	5	5	6	6	7	7	7	8	8	
26000	BEARING	3									1											2											3	
27000	BEARING COVER	3									1											2											3	
31000	SHAFT SLEEVE	3									1											2											3	
32000	IMPELLER KEY	3									1											2											3	
32100	COUPLING KEY	3									1											2											3	
33000	IMPELLER NUT	3									1											2											3	
41000	LOCK WASHER	3									1											2											3	
19100	BACK WEAR RING	7																							15	12	13	14	10	9	11	10	9	

# MECHANICAL SEAL ARRANGEMENT

## Typical Cross Sectional Drawing

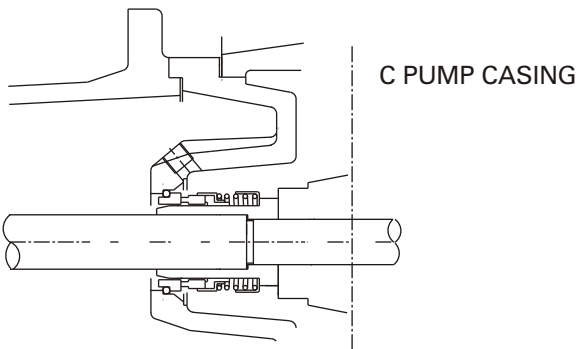
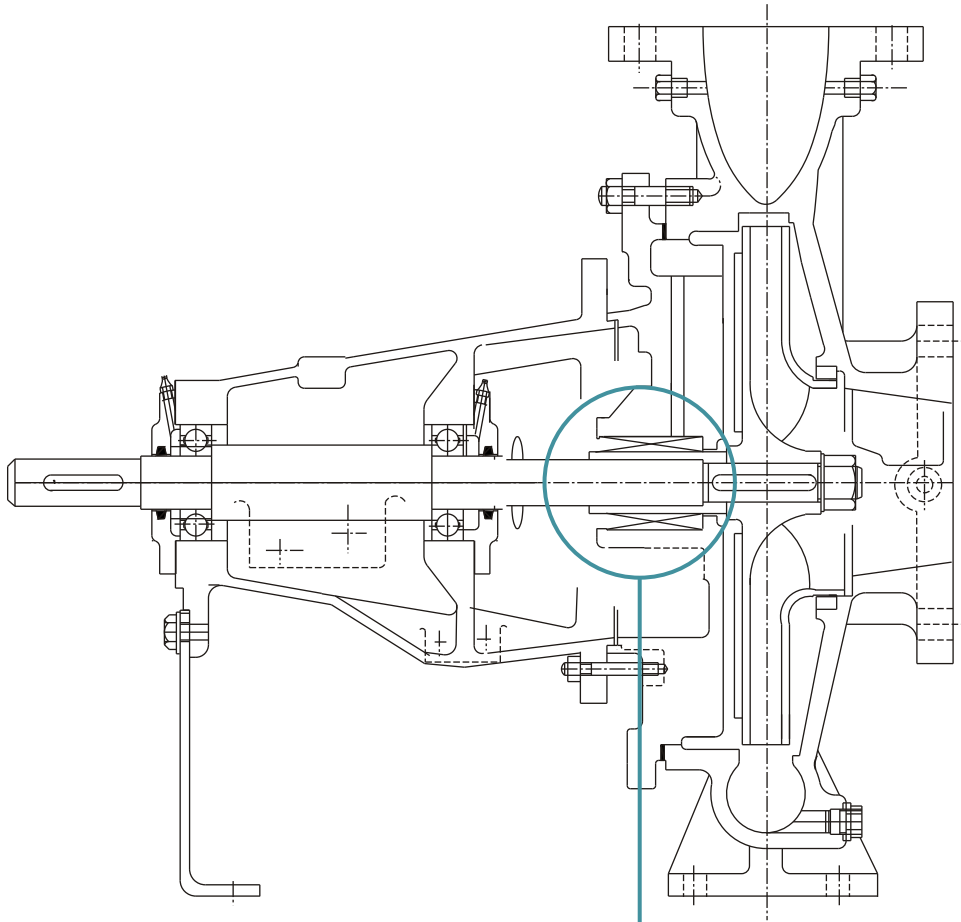

MECH SEAL ARRANGMENT FOR  
DB UNIT 25 & 35

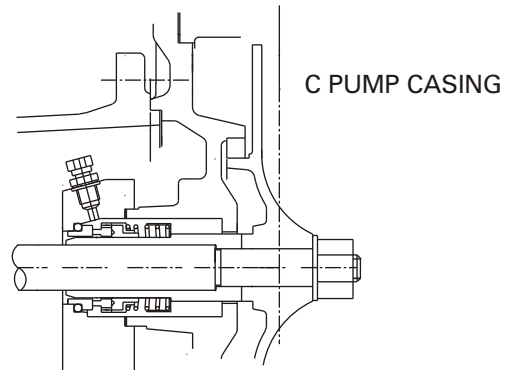

MECH SEAL ARRANGMENT FOR  
DB UNIT 45

# MATERIALS

## MATERIAL OF CONSTRUCTION

Casing	Cast Iron / Bronze / Phosphor Bronze
Casing Cover	Cast Iron / Bronze / Phosphor Bronze
Impeller	Cast Iron / Bronze / Phosphor Bronze
Wear Ring	Cast Iron / Bronze
Shaft	Carbon Steel / Stainless Steel
Shaft Sleeve	Stainless Steel / Bronze
Lantern Ring	Nylon
Gland	Cast Iron / Bronze

## MATERIAL STANDARDS - GENERAL INFORMATION

Material Type	Indian Standard (IS)	American standard (ASTM)	DIN
<b>Cast Iron</b>			
Cast Iron	IS 210 Gr. FG 260	ASTM A48 Class 40	(0.6025)DIN 1691 GG25
<b>Spheroidal Graphite Cast Iron</b>			
SG Iron (Ductile Iron)	IS 1865 Gr 400/15	A536, 60-40-18	(0.7040)DIN1693 GGG40
SG Iron (Ductile Iron)	IS 1865 Gr 500/7	A536, 65-45-12	(0.7050)DIN1693 GGG50
<b>Carbon steel</b>			
Carbon steel (Wrought)	IS 1570 (part II) Gr. 40C8	ASTM A107 Gr. 1040	(1.1186)C40E/CK40
Carbon steel (Wrought)	IS 1570 (part II) Gr. 20C8	ASTM A107 Gr. 1020	(1.0402)C22
MS Steel	MS IS 2062 - Fe 410 W A	ASTM-A283 GR.D	DIN 1700 GR ST4-2 FABRICATED STEEL44
<b>Cast Steel Grades</b>			
Cast steel		ASTMA 216 Gr. WCB	1.0619(GS-C25)
<b>Cast Stainless Steel</b>			
Stainless Steel CF8M	IS 3444 Gr. 4	ASTMA 351 Gr. CF8M	1.4408(GX5CrNiMo19-11-2)
Stainless Steel CF8M	IS 3444 Gr. 4	ASTMA 743 Gr. CF8M	1.4408(GX5CrNiMo19-11-2)
Stainless Steel CF3M	IS 3444 Gr. 16	ASTMA 351 Gr. CF3M	1.4409(GX2CrNiMo19-11-2)
Stainless Steel CF3M	IS 3444 Gr. 16	ASTMA 743 Gr. CF3M	1.4409(GX2CrNiMo19-11-2)
Stainless Steel CF8	IS 3444 Gr. 1	ASTMA 351 Gr. CF8	1.4301(X5CrNi18-10)
Stainless Steel CF3	IS 3444 Gr. 15	ASTMA 351 Gr. CF3	1.4306(X2CrNi19 11)
<b>Cast Chromium StainlessSteel</b>			
Stainless Steel CA15	IS 3444 Gr. 10	ASTMA 217 Gr. CA15	1.4106&1.448(DIN17445 GX12Cr14)
Stainless Steel CA15	IS 3444 Gr. 10	ASTMA 743 Gr. CA15	1.4106&1.448(DIN17445 GX12Cr14)
Stainless Steel CA6NM	IS 3444 Gr. 24	ASTMA 487 Gr. CA6NM	1.4313&1.4317(GX5CrNiMo13-4)
Stainless Steel CA6NM	IS 3444 Gr. 24	ASTMA 743 Gr. CA6NM	1.4313&1.4317(GX5CrNiMo13-4)
<b>Chromium StainlessSteel Round Bar Matherial</b>			
Stainless steel 410	IS 1570 (part V) Gr. X12Cr12	ASTMA 276 type 410	1.4006(X10Cr13)
Stainless steel 420	IS 1570 (part V) Gr. X20Cr13	ASTMA 276 type 420	1.4021(X20Cr13)
Stainless steel 431	IS 1570 (part V) Gr. X15Cr16Ni2	ASTMA 276 type 431	1.4057(X20CrNi17)
Stainless steel 316	IS 1570 (part V) Gr. X04Cr17Ni12Mo2	ASTMA 276 type 316	1.4401(X5CrNiMo17122)
Stainless steel 316L	IS 1570 (part V) Gr. X02Cr17Ni12Mo2	ASTMA 276 type316L	1.4404(X2CrNiMo1810)
<b>Cast Duplex Steel</b>			
Duplex Steel 1A		ASTMA 890 Gr. CD4MCu	25Cr-5Ni-Mo-Cu
Duplex Steel 2A		ASTMA 890 Gr. CE8MN	24Cr-10Ni-Mo-N
Duplex Steel 3A		ASTMA 890 Gr. CD6MN	25Cr-5Ni-Mo-N
Super Duplex steel 4A		ASTMA 890 Gr. CD3MN	25Cr-7Ni-Mo-N
Super Duplex steel 5A		ASTMA 890 Gr. CE3MN	24Cr-10Ni-Mo-N
<b>Non Ferious Materials</b>			
Bronze	IS 318 Gr. LTB2 (CuSn5Zn5Pb5C)	ASTMB 584 - C90500	DIN 1705 Rg 5
Phosphor Bronze	IS 28 Gr. 1 (CuSn11PC)		
Zinc Free Bornze	IS 28 Gr. 1 (CuSn10C)		

Family Curves of DB Pump at 1450 rpm-50Hz

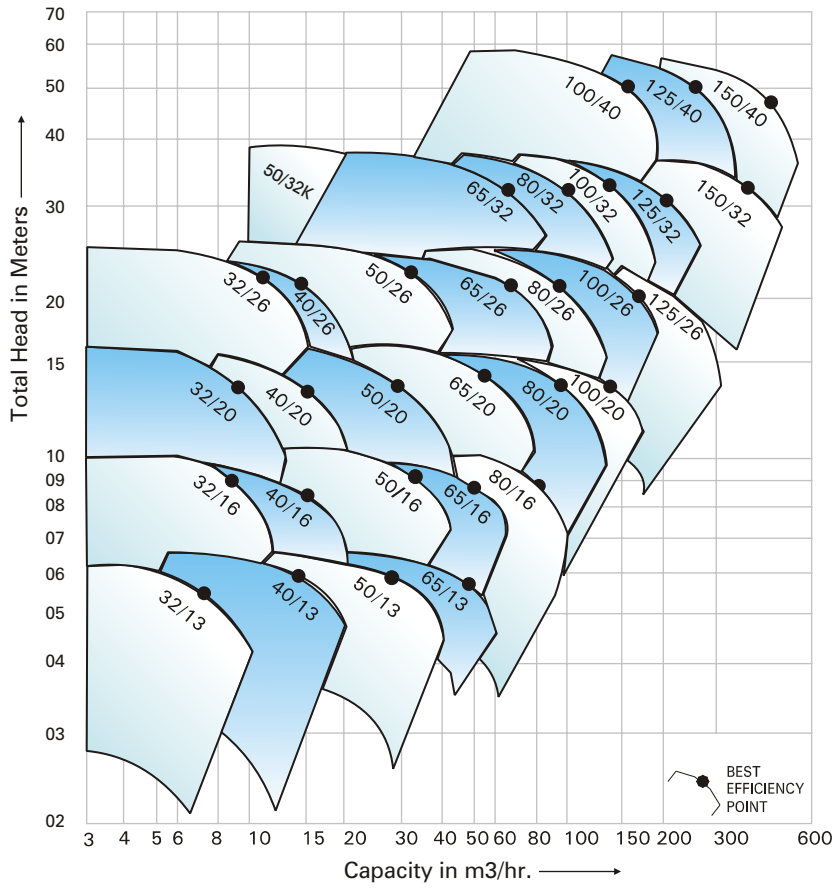

Family Curves of DB Pump at 2900 rpm-50Hz

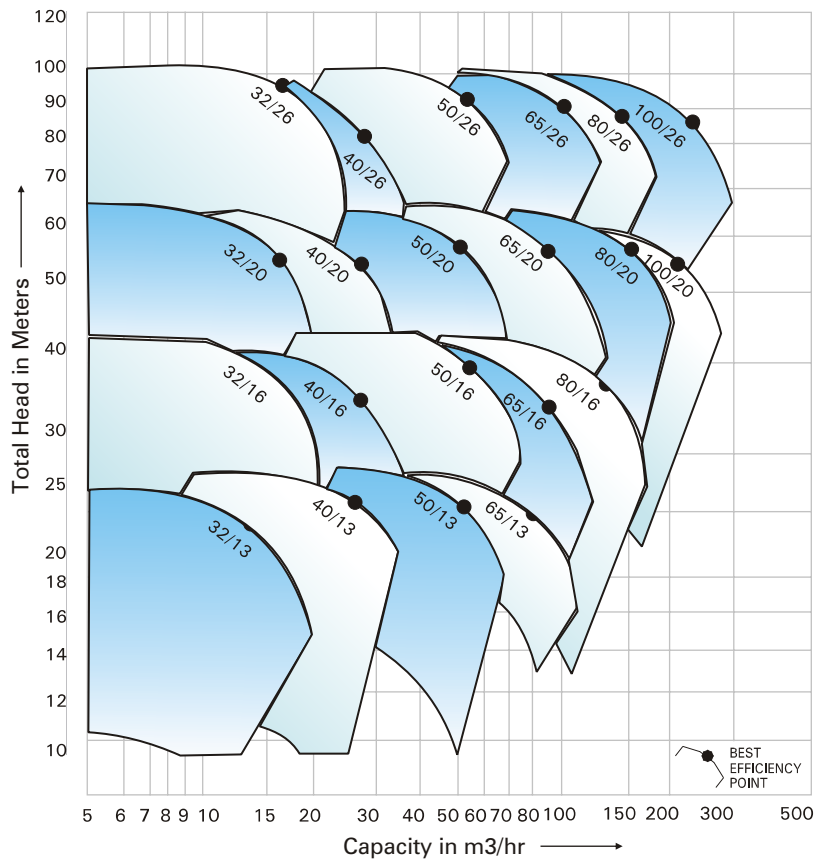

## Performance Curves

### DB Pump Models at 980 rpm

<b>Sr No.</b>	<b>Pump Type</b>	<b>Curve No.</b>
01	DB 100/40	HD 10225C0
02	DB 125/26	HD 10226C0
03	DB 125/32	HD 10227C0
04	DB 125/40	HD 10228C0
05	DB 150/32	HD 10229C0
06	DB 150/40	HD 10230C0

### DB Pump Models at 1450 rpm

<b>Sr No.</b>	<b>Pump Type</b>	<b>Curve No.</b>
07	DB 32/13	HD 10201B0
08	DB 32/16	HD 10202B0
09	DB 32/20	HD 10203B0
10	DB 32/26	HD 10204B0
11	DB 40/13	HD 10205B0
12	DB 40/16	HD 10206B0
13	DB 40/20	HD 10207B0
14	DB 40/26	HD 10208B0
15	DB 50/13	HD 10209B0
16	DB 50/16	HD 10210B0
17	DB 50/20	HD 10211B0
18	DB 50/26	HD 10212B0
19	DB 50/32K	HD 10232AB00
20	DB 65/13	HD 10213B0
21	DB 65/16	HD 10214B0
22	DB 65/20	HD 10215B0
23	DB 65/26	HD 10216B0
24	DB 65/32	HD 10217B0-R
25	DB 80/16	HD 10218B0
26	DB 80/20	HD 10219B0
27	DB 80/26	HD 10220B0
28	DB 80/32	HD 10221B0
29	DB 100/20	HD 10222B0
30	DB 100/26	HD 10223B0
31	DB 100/32	HD 10224B0
32	DB 100/40	HD 10225B0
33	DB 125/26	HD 10226B0
34	DB 125/32	HD 10227B0
35	DB 125/40	HD 10228B0
36	DB 150/32	HD 10229B0
37	DB 150/40	HD 10230B0

## Performance Curves

### DB Pump Models at 2900 rpm

<b>Sr No.</b>	<b>Pump Type</b>	<b>Curve No.</b>
38	DB 32/13	HD 10201A0
39	DB 32/16	HD 10202A0
40	DB 32/20	HD 10203A0
41	DB 32/26	HD 10204A0
42	DB 40/13	HD 10205A0
43	DB 40/16	HD 10206A0
44	DB 40/20	HD 10207A0
45	DB 40/26	HD 10208A0
46	DB 50/13	HD 10209A0
47	DB 50/16	HD 10210A0
48	DB 50/20	HD 10211A0
49	DB 50/26	HD 10212A0
50	DB 65/13	HD 10213A0
51	DB 65/16	HD 10214A0-R
52	DB 65/20	HD 10215A0
53	DB 65/26	HD 10216A0
54	DB 80/16	HD 10218A0
55	DB 80/20	HD 10219A0
56	DB 80/26	HD 10220A0-R
57	DB 100/20	HD 10222A0
58	DB 100/26	HD 10223A0

# KIRLOSKAR BROTHERS LIMITED

NO. HD10225C0

## PERFORMANCE CURVE OF PUMP DB 100/40

SUC. 125 mm DEL 100 mm

THIS CURVE RELATES TO LIQUID OF SP.GR. = 1.0

n = 950 rpm  
(NOMINAL)



Enriching Lives

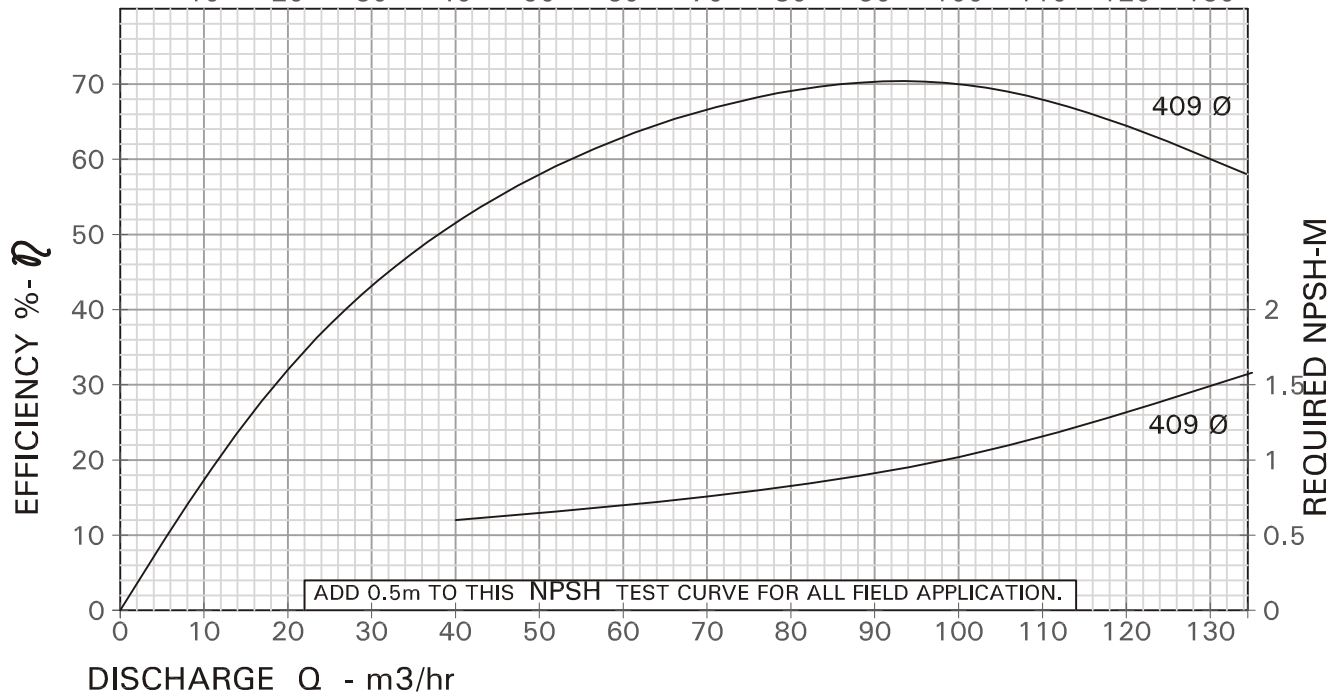
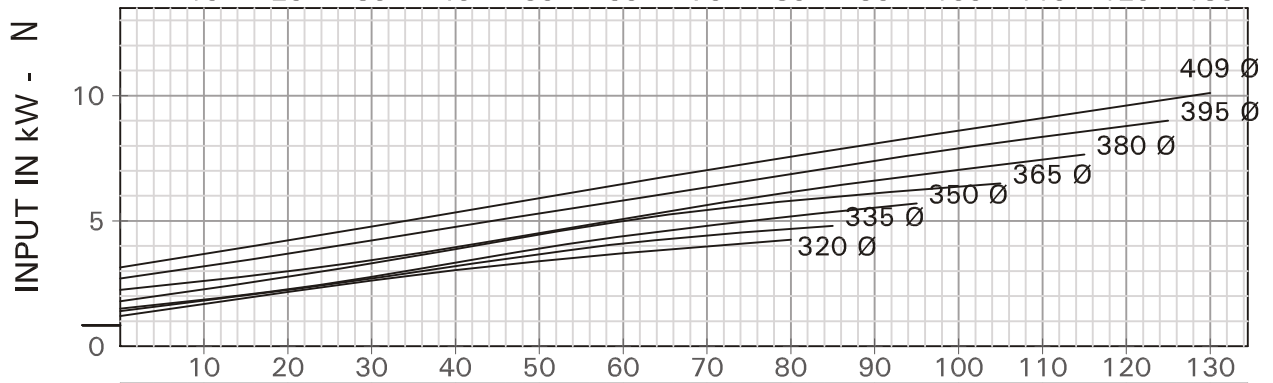
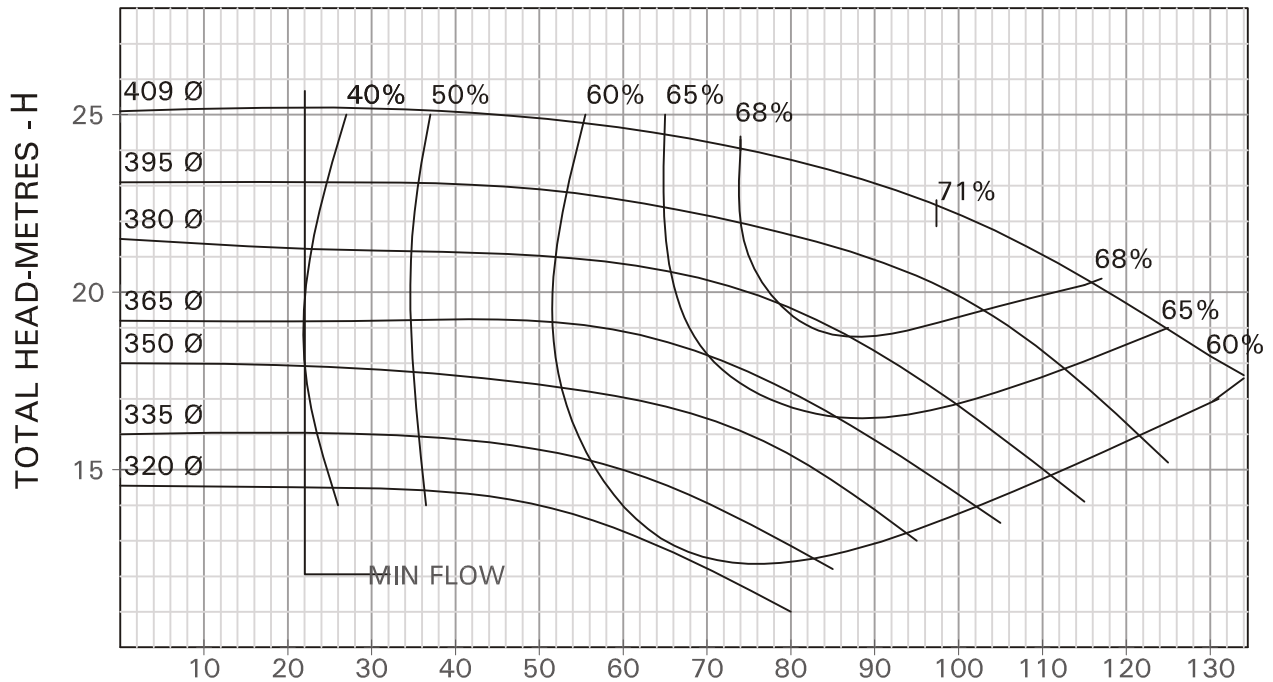

RECOMMENDED DELIVERY PIPE SIZE mm	80	100	125	150	
RECOMMENDED SUCTION PIPE SIZE mm	100	125	150	175	

# KIRLOSKAR BROTHERS LIMITED

NO. HD10226C0

## PERFORMANCE CURVE OF PUMP DB 125/26

SUC. 150 mm DEL 125 mm

THIS CURVE RELATES TO LIQUID OF SP.GR. = 1.0

n = 950 rpm  
(NOMINAL)



Enriching Lives

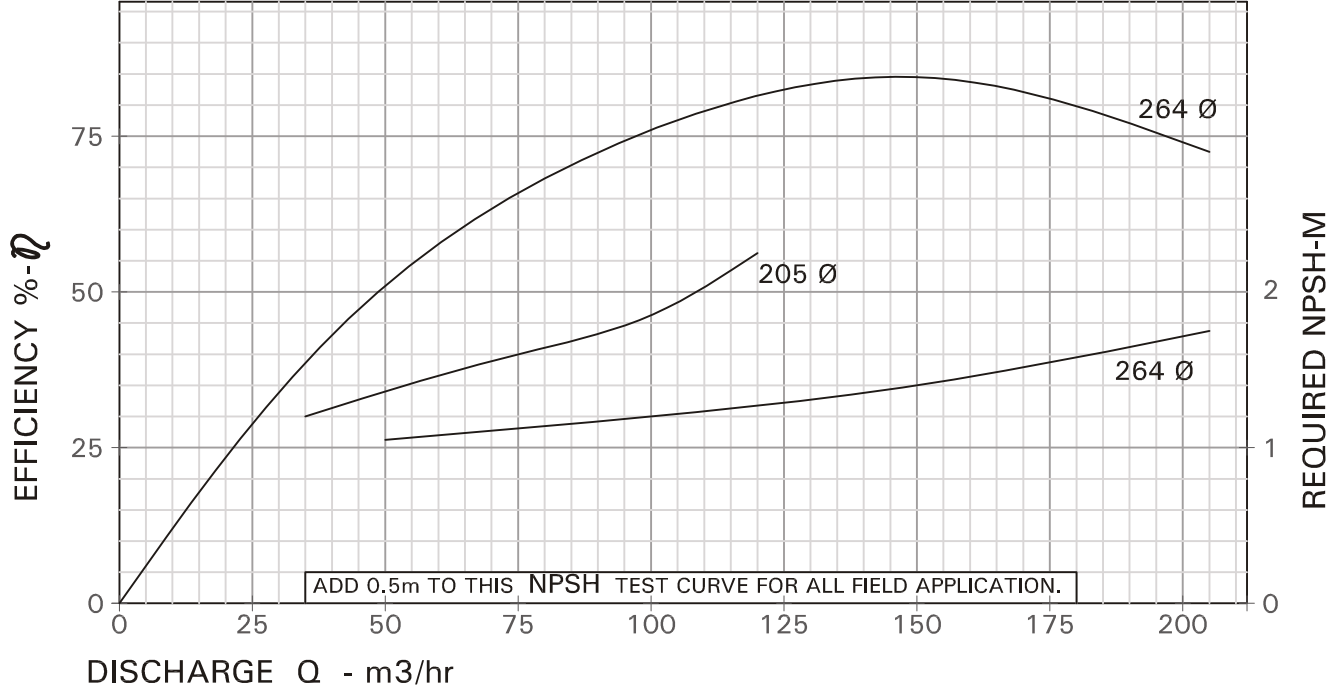
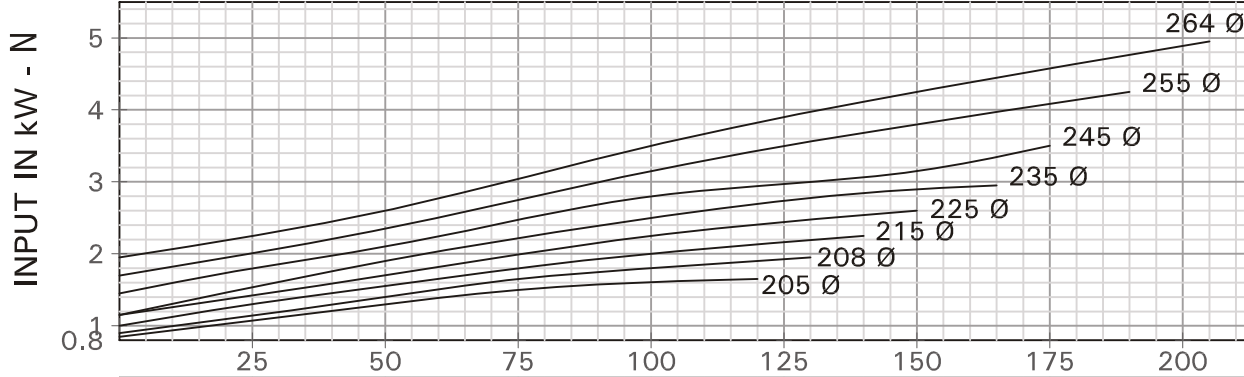
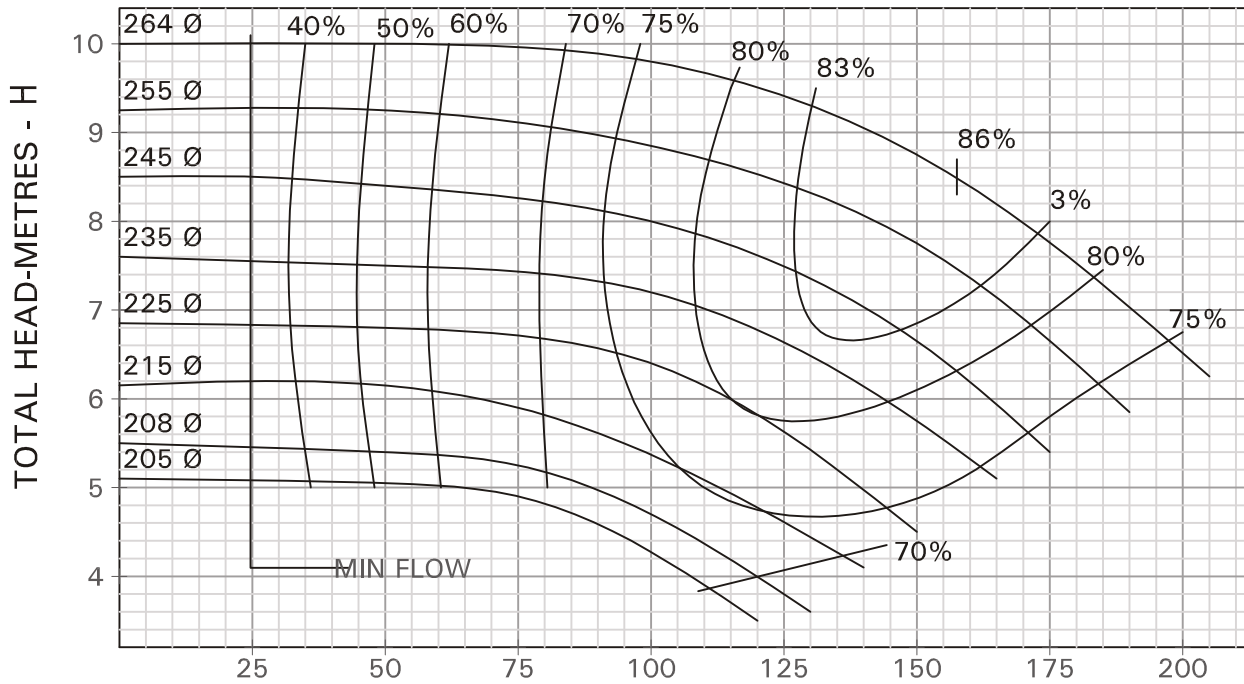

RECOMMENDED DELIVERY PIPE SIZE mm	100	125	150	175	200	
RECOMMENDED SUCTION PIPE SIZE mm	100	125	150	175	200	225

# KIRLOSKAR BROTHERS LIMITED

NO. HD10227C0

## PERFORMANCE CURVE OF PUMP DB 125/32

SUC. 150 mm DEL. 125 mm

THIS CURVE RELATES TO LIQUID OF SP.GR. = 1.0

n = 950 rpm  
(NOMINAL)



Enriching Lives

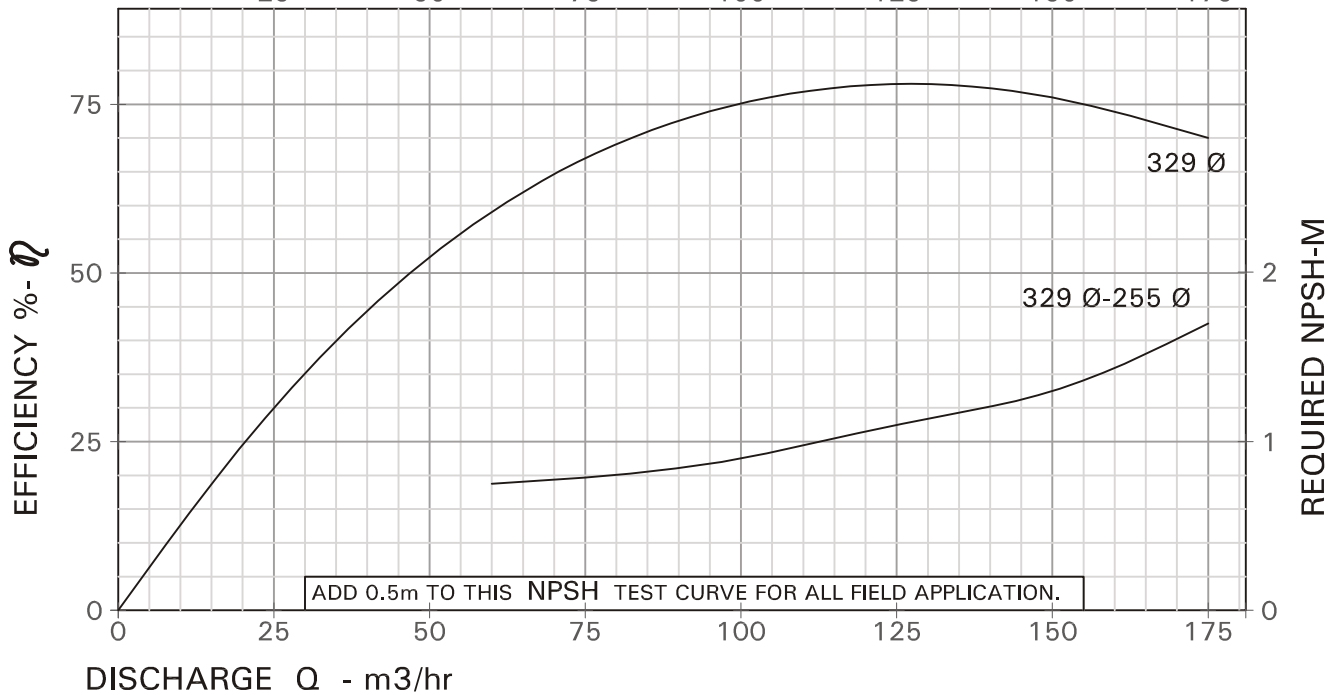
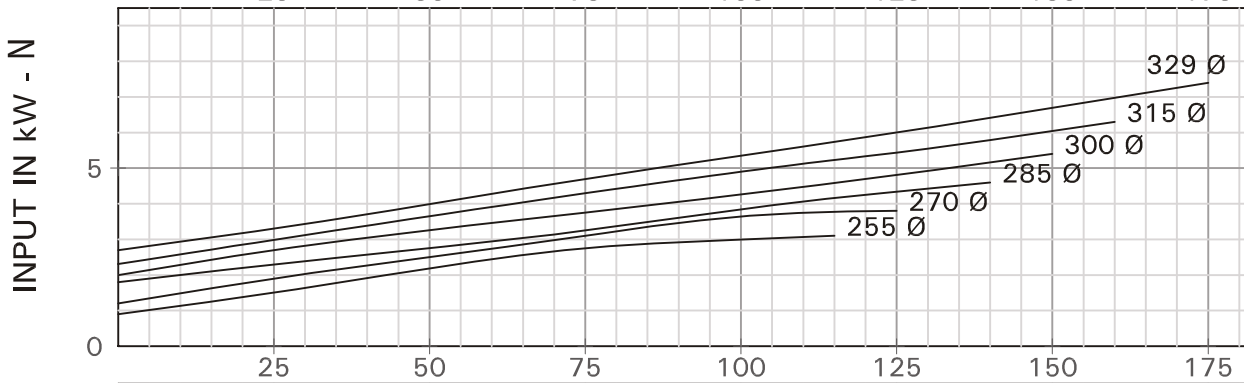
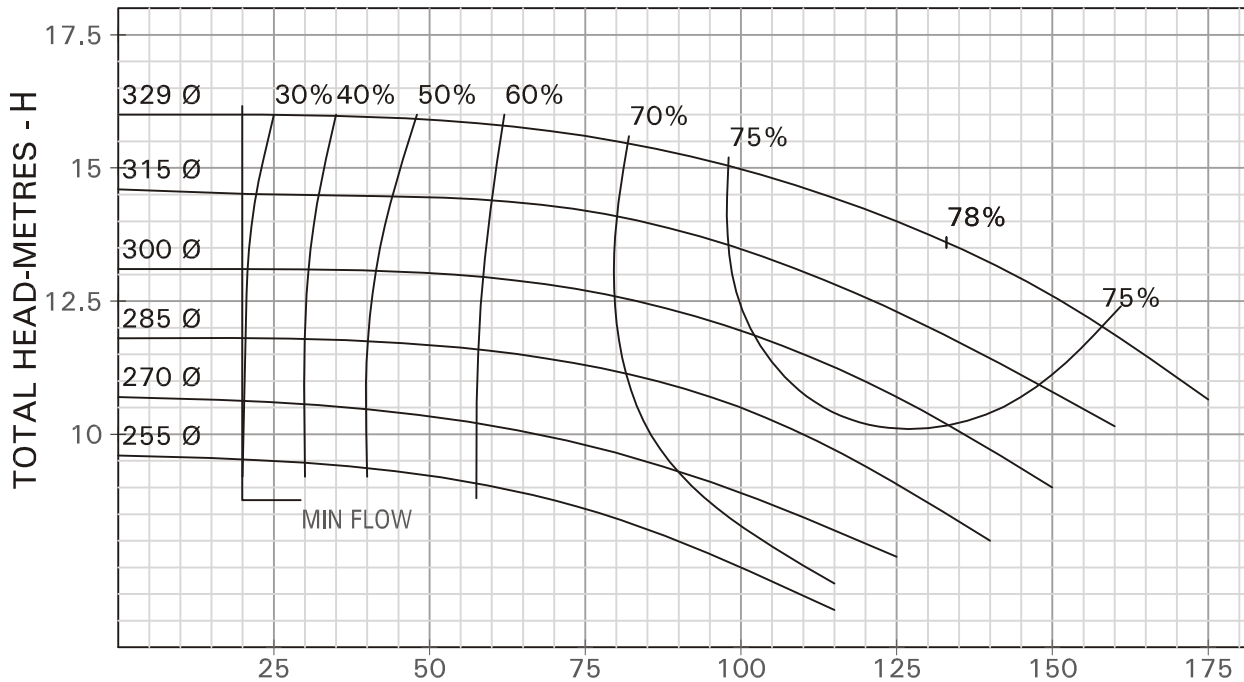

RECOMMENDED DELIVERY PIPE SIZE mm	100	125	150	175	
RECOMMENDED SUCTION PIPE SIZE mm	100	125	150	175	200

# KIRLOSKAR BROTHERS LIMITED

NO. HD10228C0

## PERFORMANCE CURVE OF PUMP DB 125/40

SUC. 150 mm DEL. 125 mm

THIS CURVE RELATES TO LIQUID OF SP.GR. = 1.0

n = 950 rpm  
(NOMINAL)



Enriching Lives

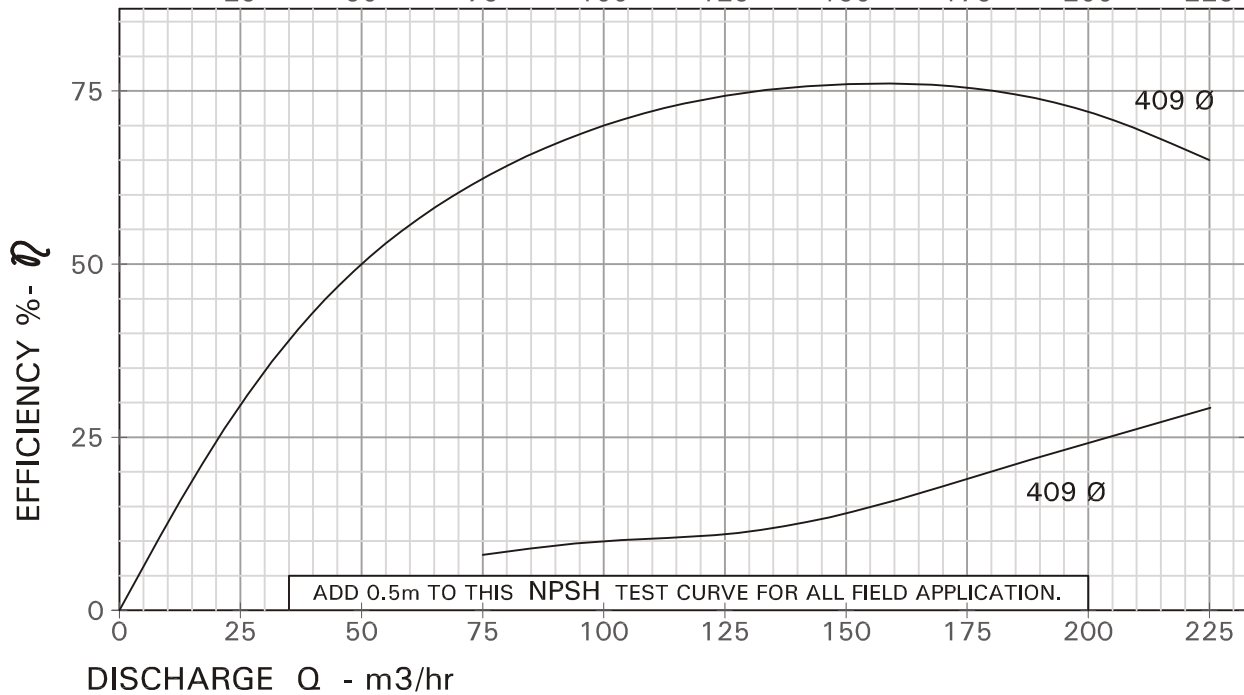
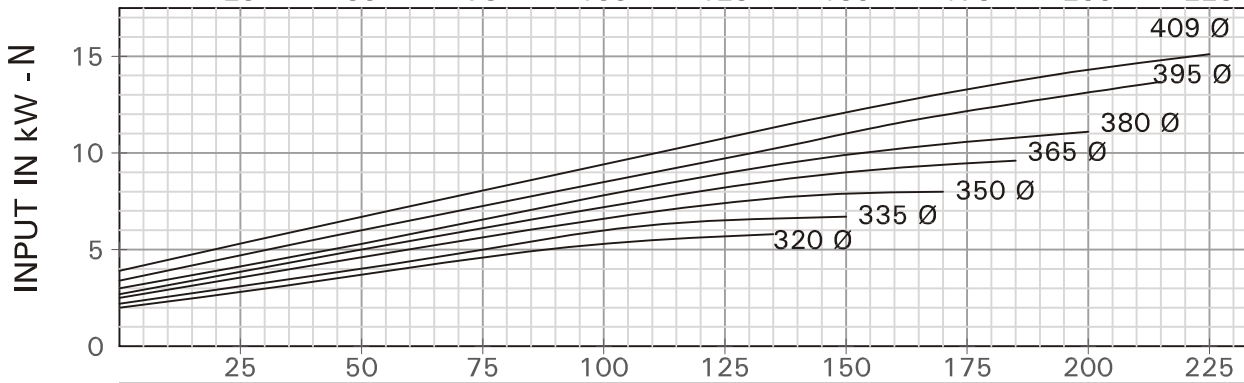
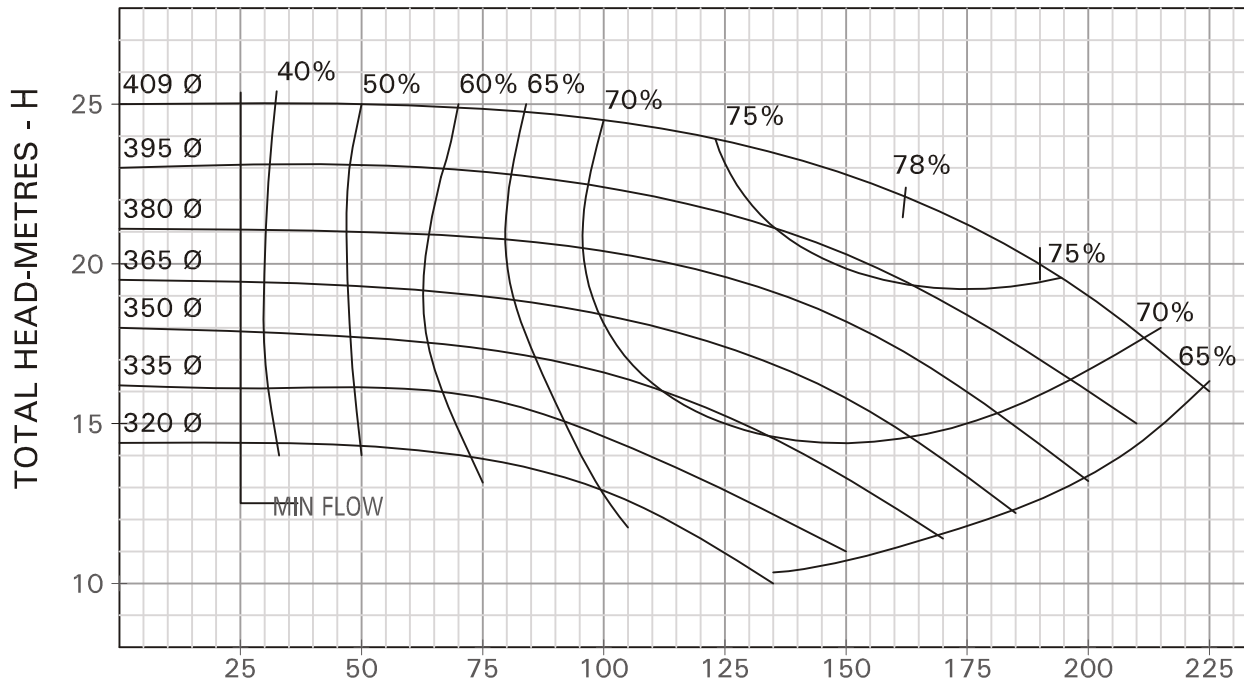

ADD 0.5m TO THIS NPSH TEST CURVE FOR ALL FIELD APPLICATION.

RECOMMENDED DELIVERY PIPE SIZE mm	100	125	150	175	200	
RECOMMENDED SUCTION PIPE SIZE mm	100	125	150	175	200	225

# KIRLOSKAR BROTHERS LIMITED

NO. HD10229C0

## PERFORMANCE CURVE OF PUMP DB 150/32

SUC. 200 mm DEL. 150 mm

THIS CURVE RELATES TO LIQUID OF SP.GR. = 1.0

n = 950 rpm  
(NOMINAL)



Enriching Lives

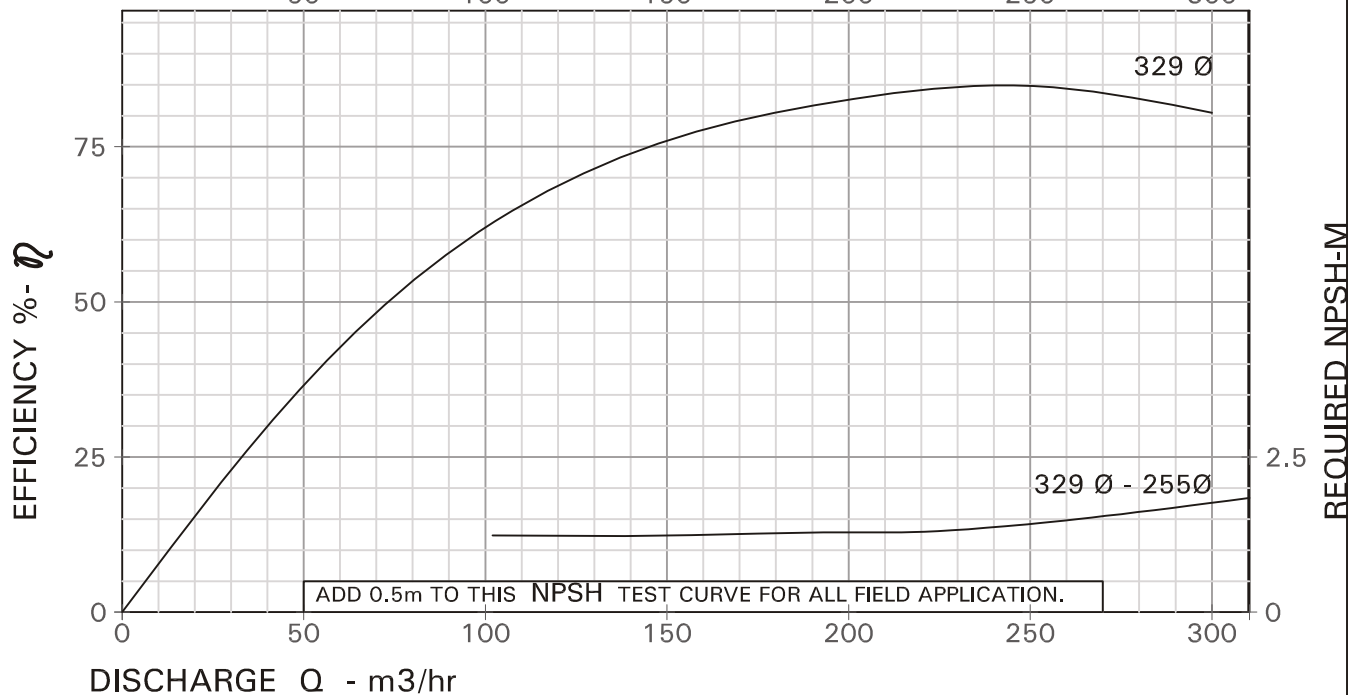
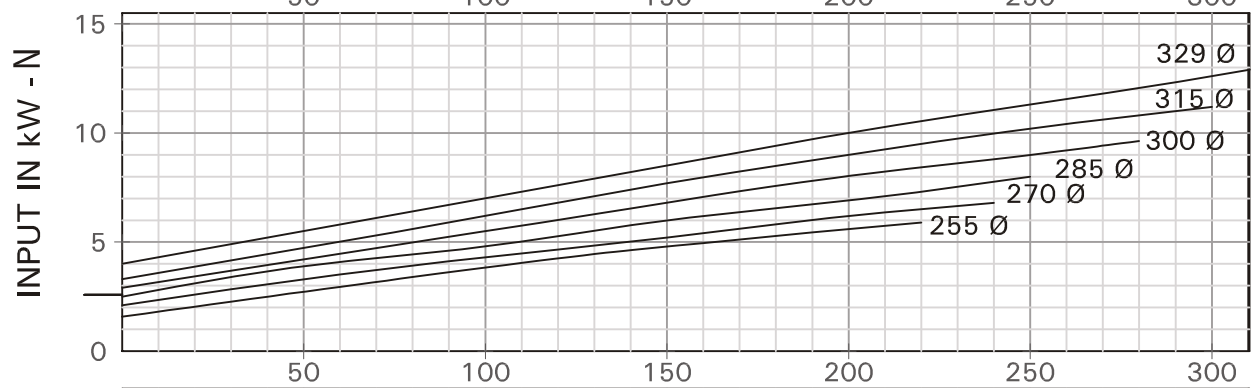
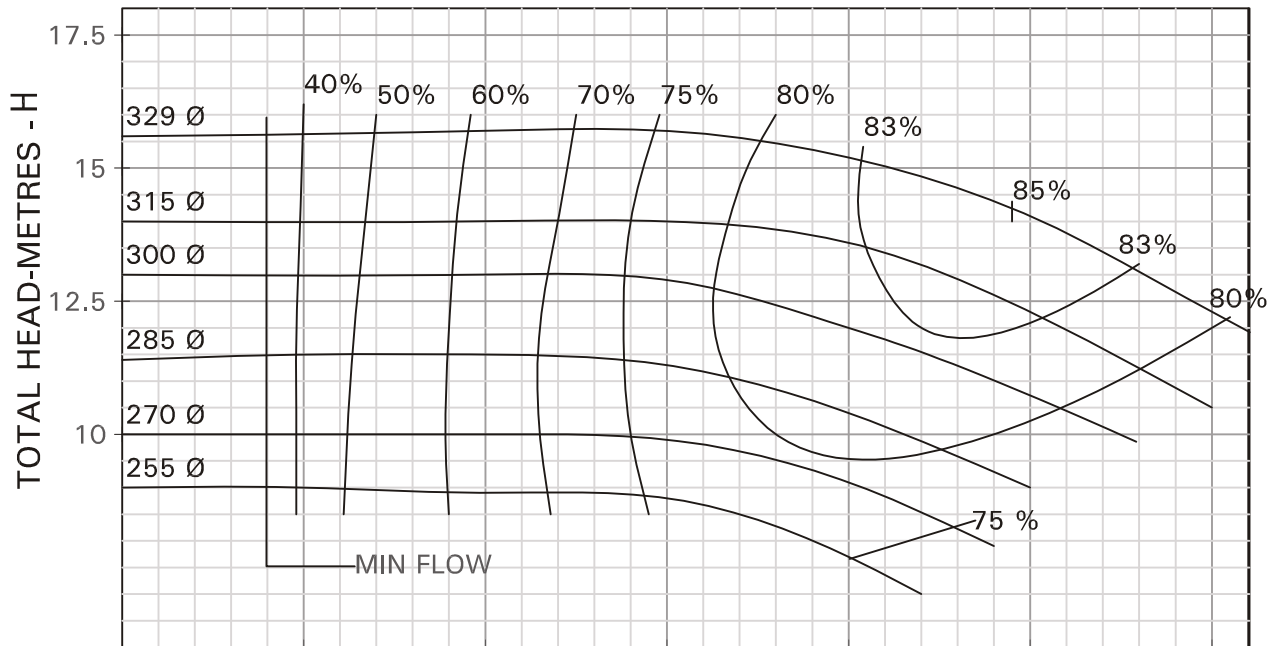

RECOMMENDED DELIVERY PIPE SIZE mm	125	150	175	200	225	
RECOMMENDED SUCTION PIPE SIZE mm	150	175	200	225	250	

# KIRLOSKAR BROTHERS LIMITED

NO. HD10230C0

## PERFORMANCE CURVE OF PUMP DB 150/40

SUC. 200 mm DEL 150 mm

THIS CURVE RELATES TO LIQUID OF SP.GR. = 1.0

n = 950 rpm  
(NOMINAL)



Enriching Lives

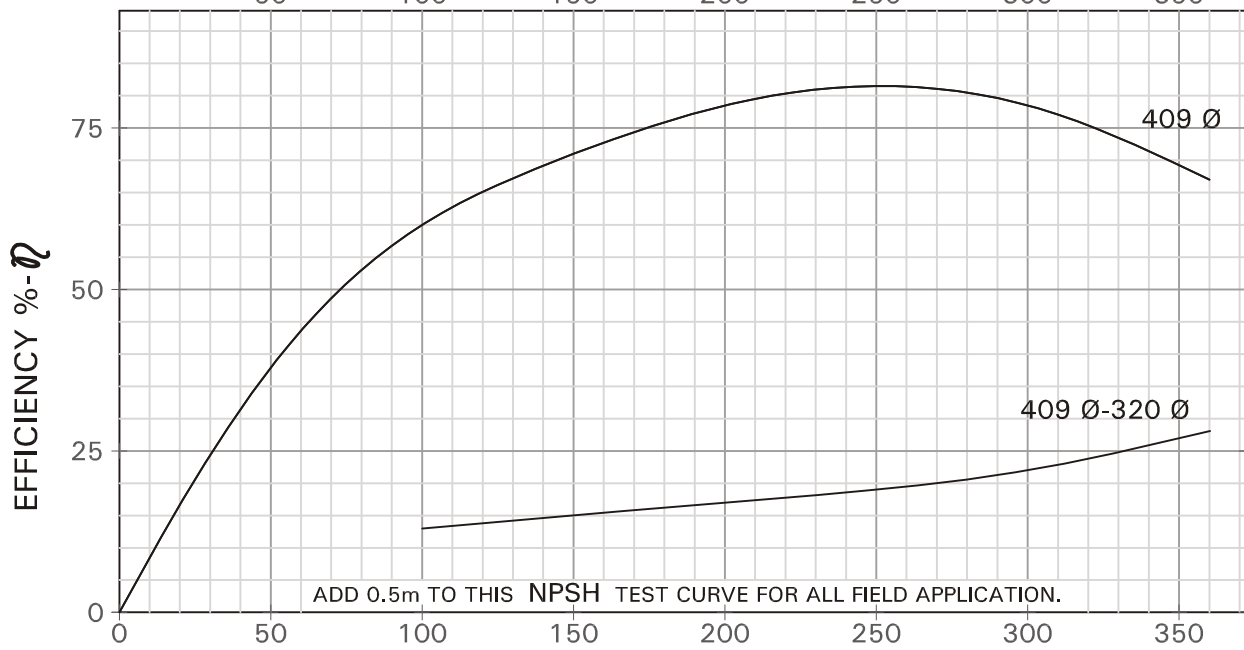
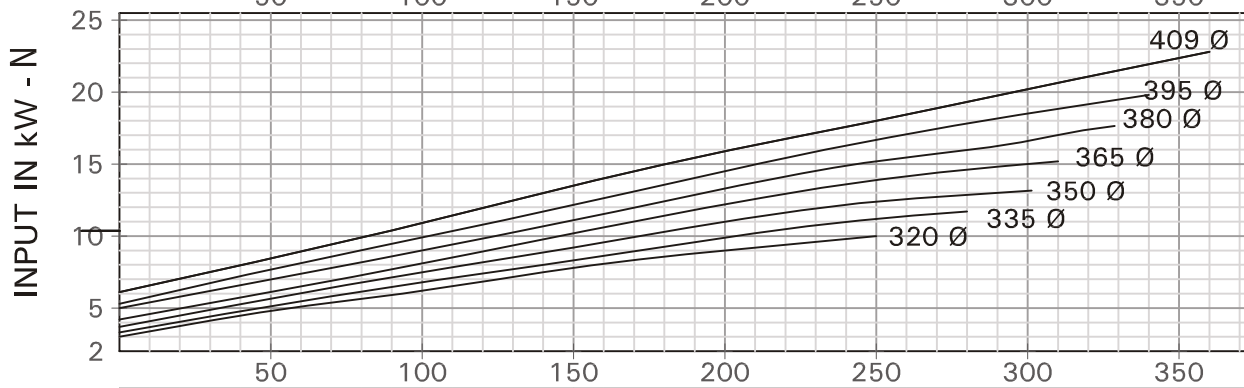
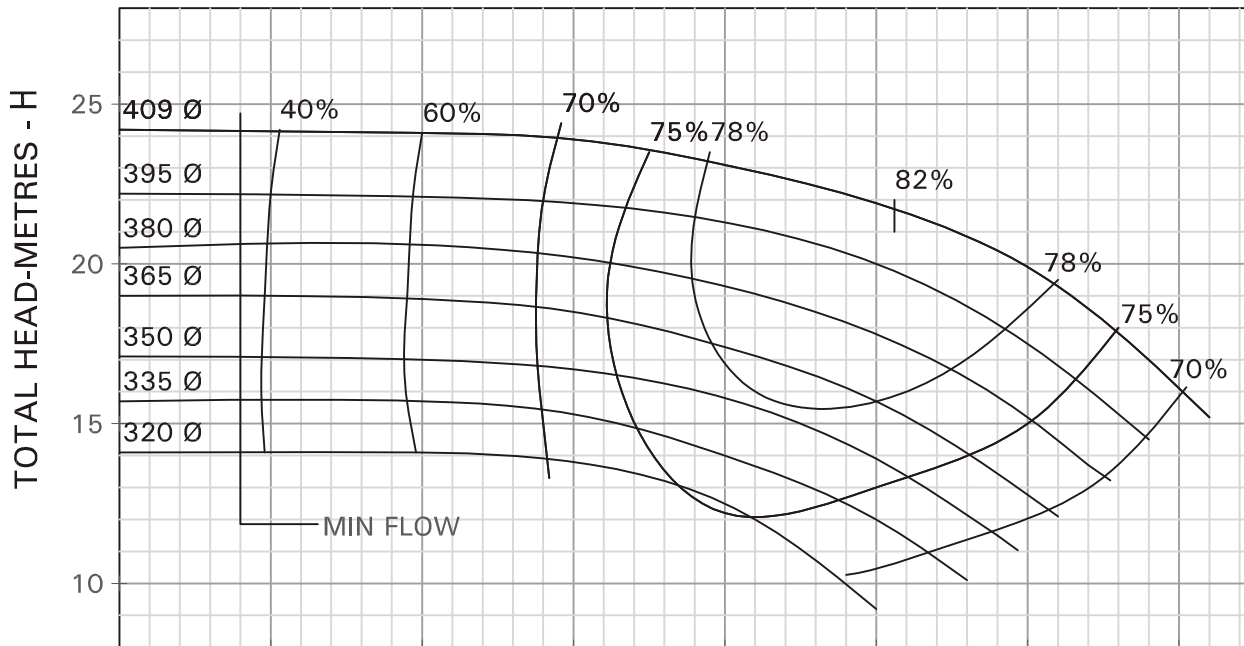

REQUIRED NPSH-M

DISCHARGE Q - m3/hr

RECOMMENDED DELIVERY PIPE SIZE mm	125	150	175	200	225	250	
RECOMMENDED SUCTION PIPE SIZE mm	150	175	200	225	250	300	

# KIRLOSKAR BROTHERS LIMITED

NO. HD10201B0

## PERFORMANCE CURVE OF PUMP DB 32/13

SUC. 50 mm DEL 32mm

THIS CURVE RELATES TO LIQUID OF SP.GR. = 1.0

$n = 1450^{rpm}$   
(NOMINAL)



Enriching Lives

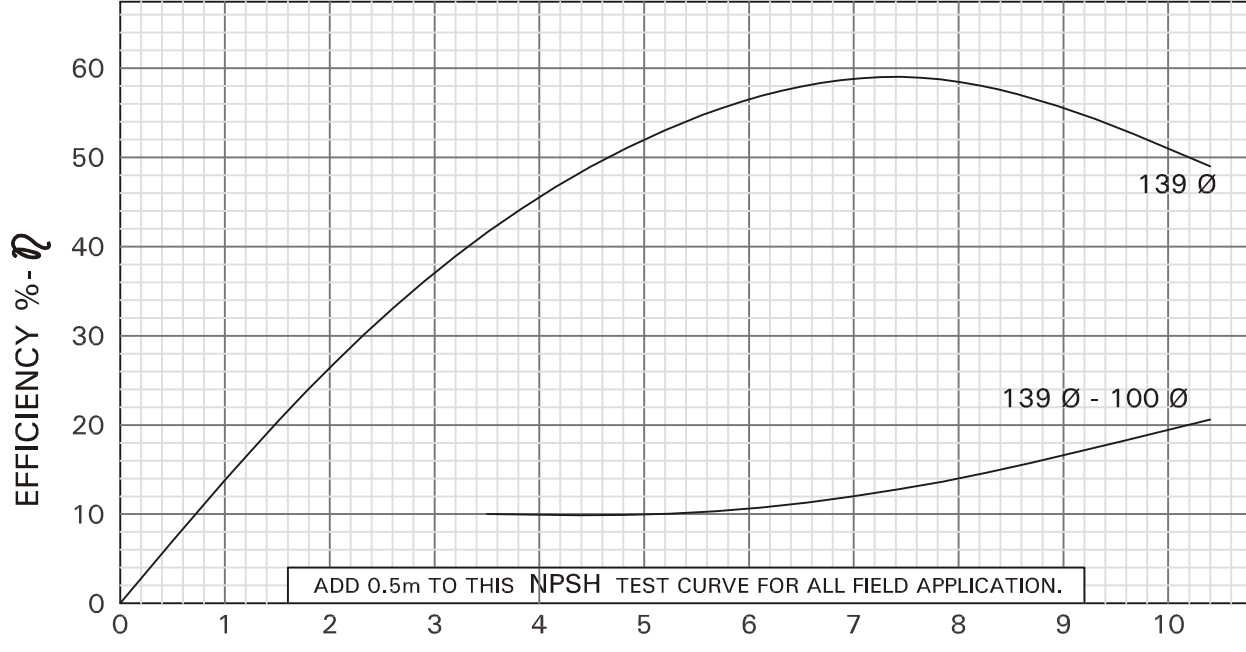
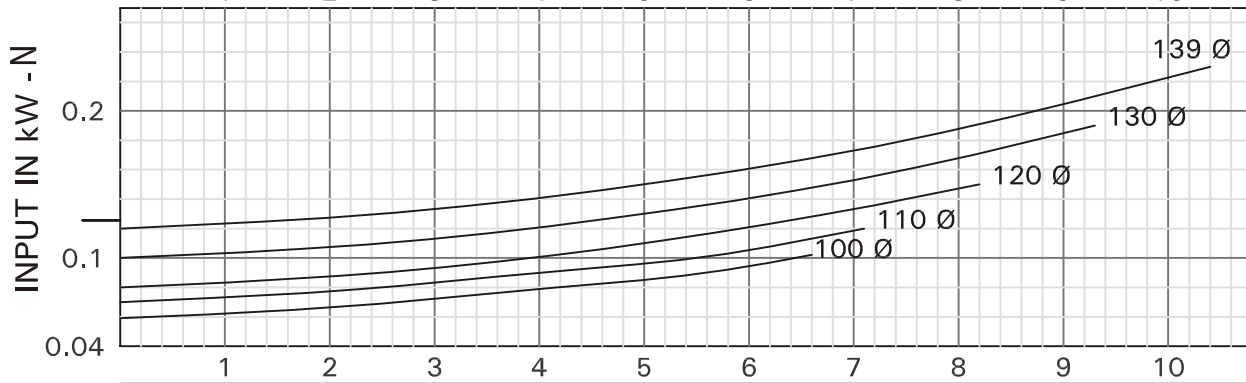
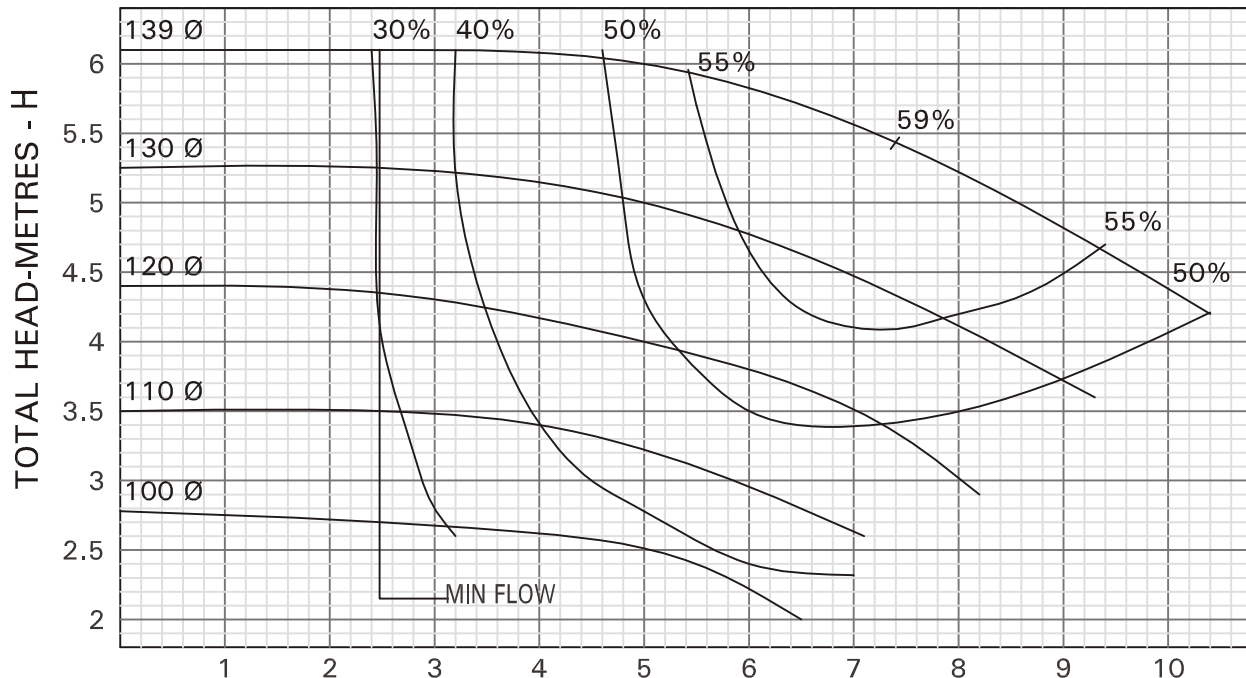

DISCHARGE Q - m3/hr

RECOMMENDED DELIVERY PIPE SIZE mm	40	50	
RECOMMENDED SUCTION PIPE SIZE mm	50	65	

# KIRLOSKAR BROTHERS LIMITED

NO. HD10202B0

## PERFORMANCE CURVE OF PUMP DB 32/16

SUC. 50 mm DEL 32 mm

THIS CURVE RELATES TO LIQUID OF SP.GR. = 1.0

n = 1450<sup>rpm</sup>  
(NOMINAL)



Enriching Lives

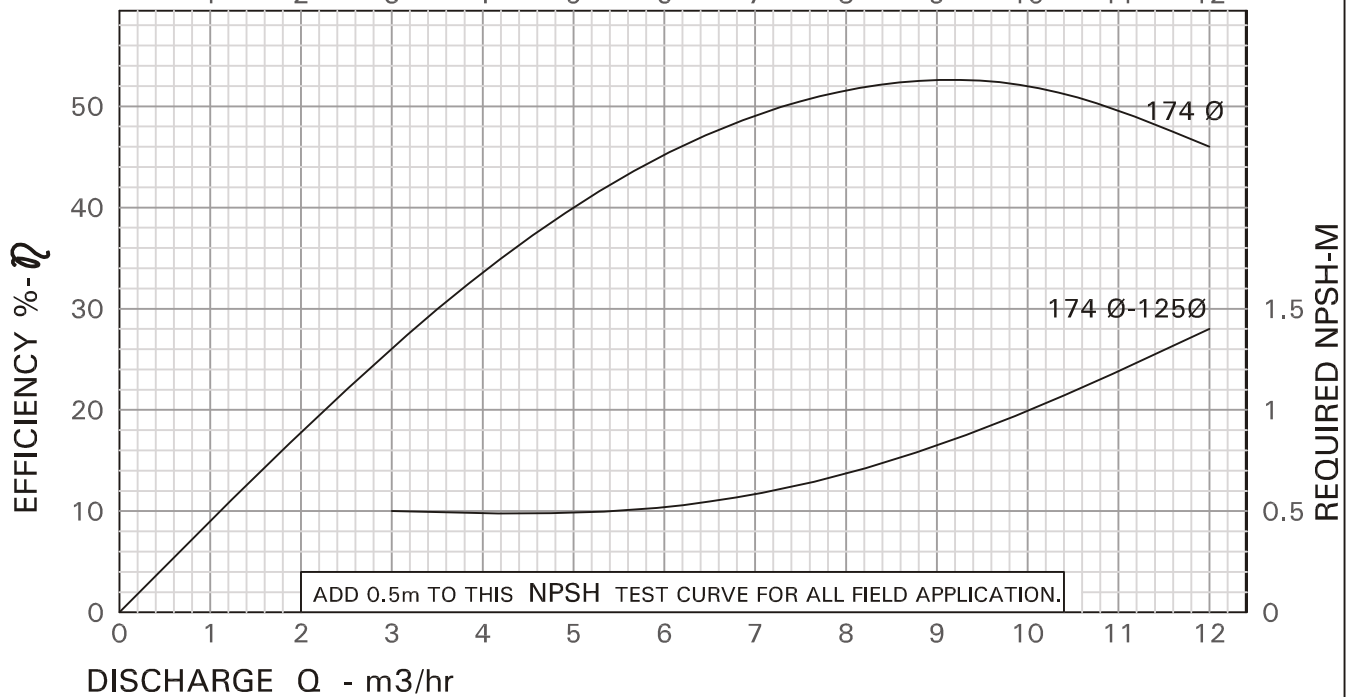
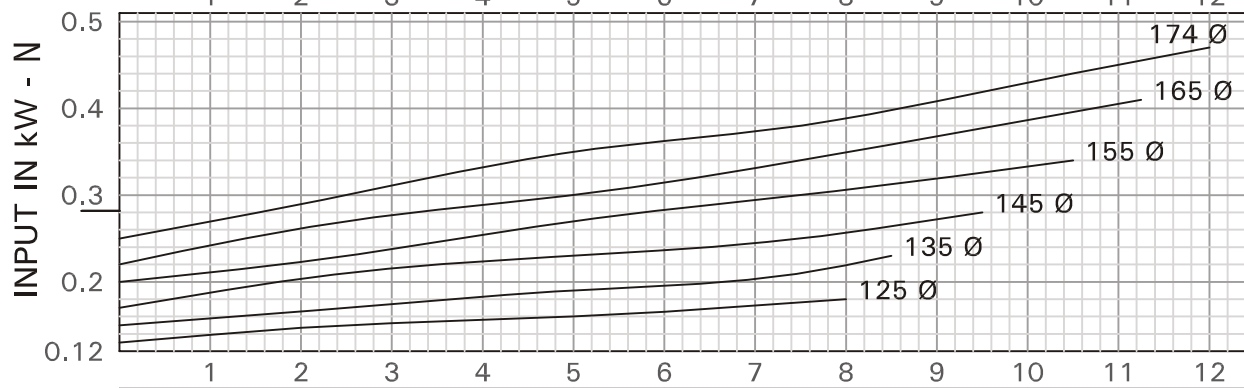
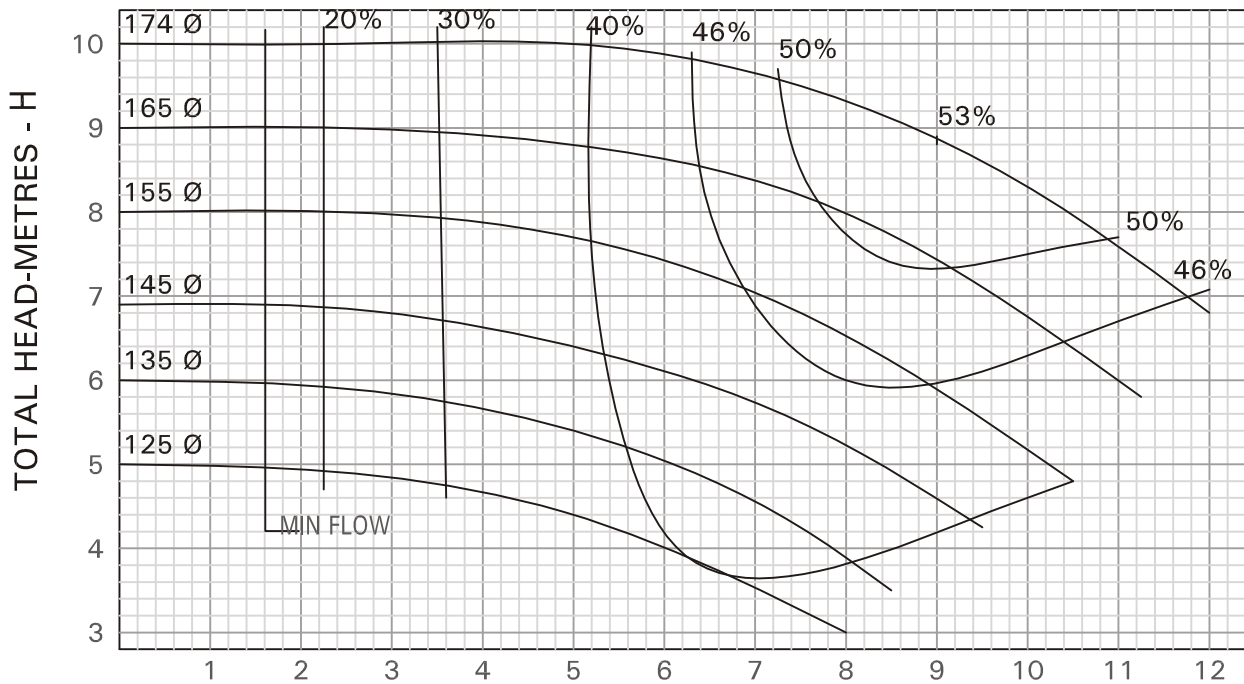

RECOMMENDED DELIVERY PIPE SIZE mm	40	50	65	
RECOMMENDED SUCTION PIPE SIZE mm	50	65		

# KIRLOSKAR BROTHERS LIMITED

NO. HD10203B0

## PERFORMANCE CURVE OF PUMP DB 32/20

SUC. 50 mm DEL 32mm

THIS CURVE RELATES TO LIQUID OF SP.GR. = 1.0

n = 1450<sup>rpm</sup>  
(NOMINAL)



Enriching Lives

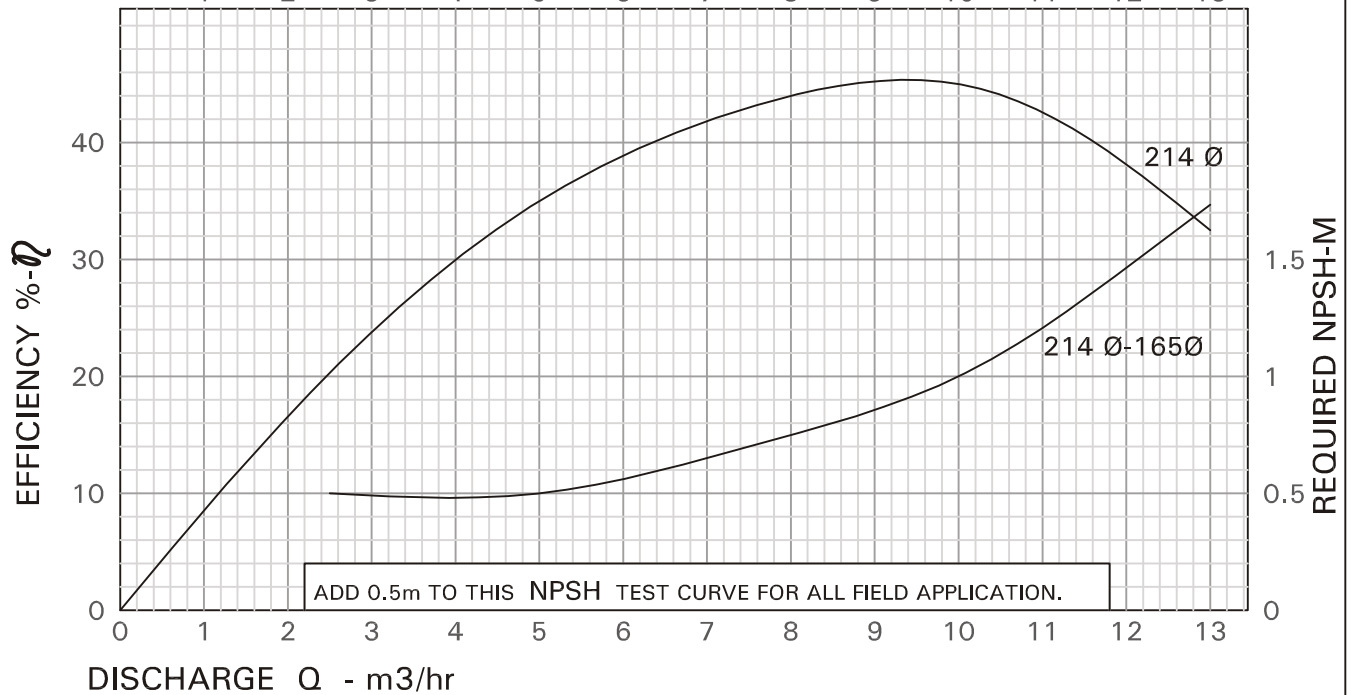
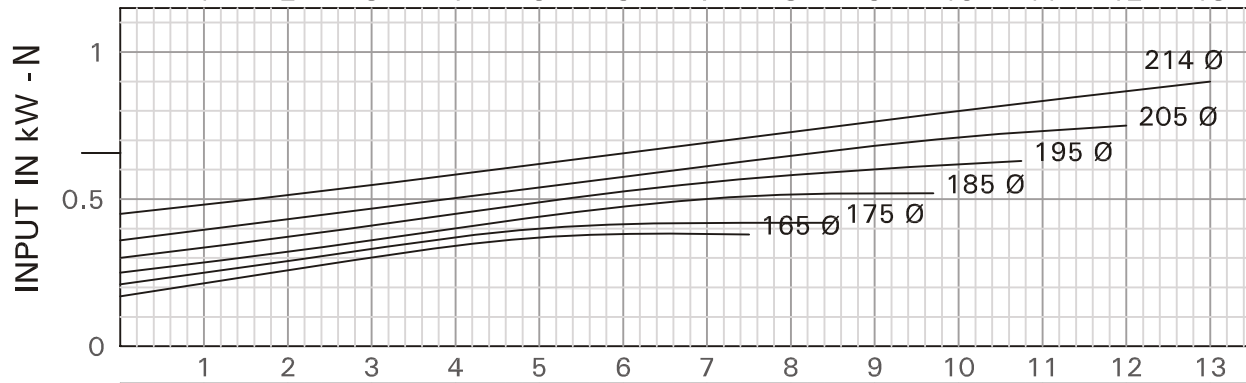
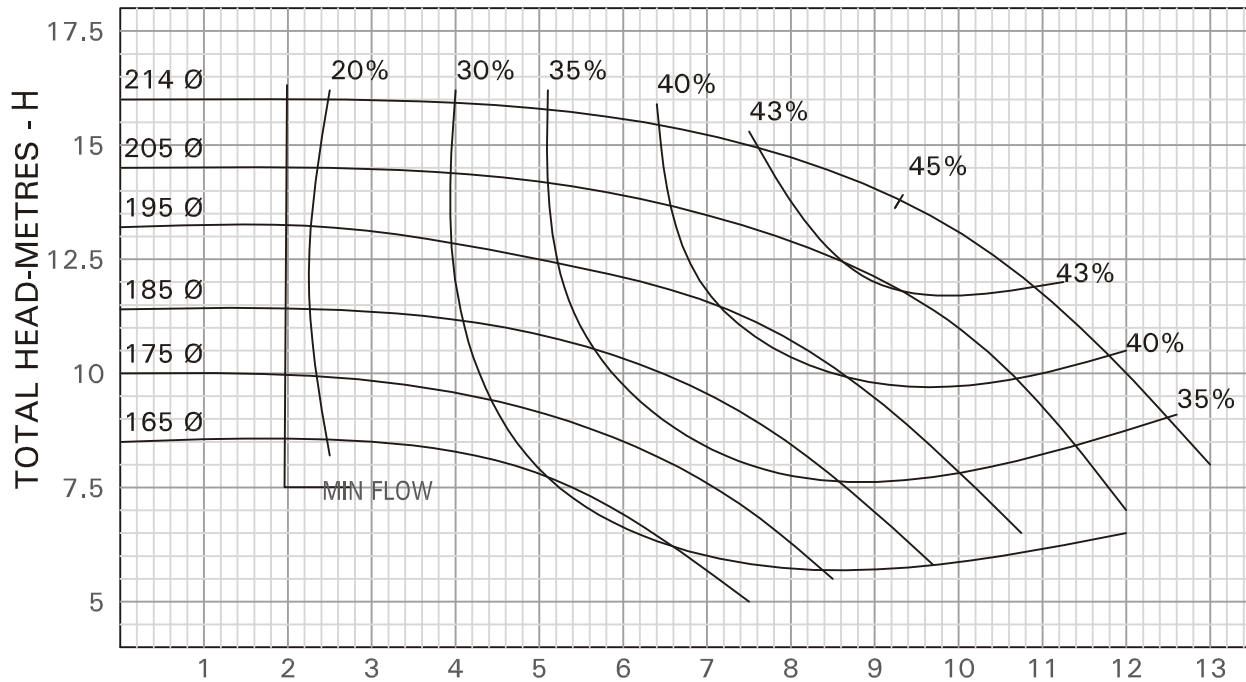

RECOMMENDED DELIVERY PIPE SIZE mm	40	50	65	
RECOMMENDED SUCTION PIPE SIZE mm	50		65	

**KIRLOSKAR BROTHERS LIMITED**

NO. HD10204B0

**PERFORMANCE CURVE OF PUMP DB 32/26**

SUC. 50 mm DEL 32 mm

THIS CURVE RELATES TO LIQUID OF SP.GR. = 1.0

n = 1450 rpm  
(NOMINAL)



Enriching Lives

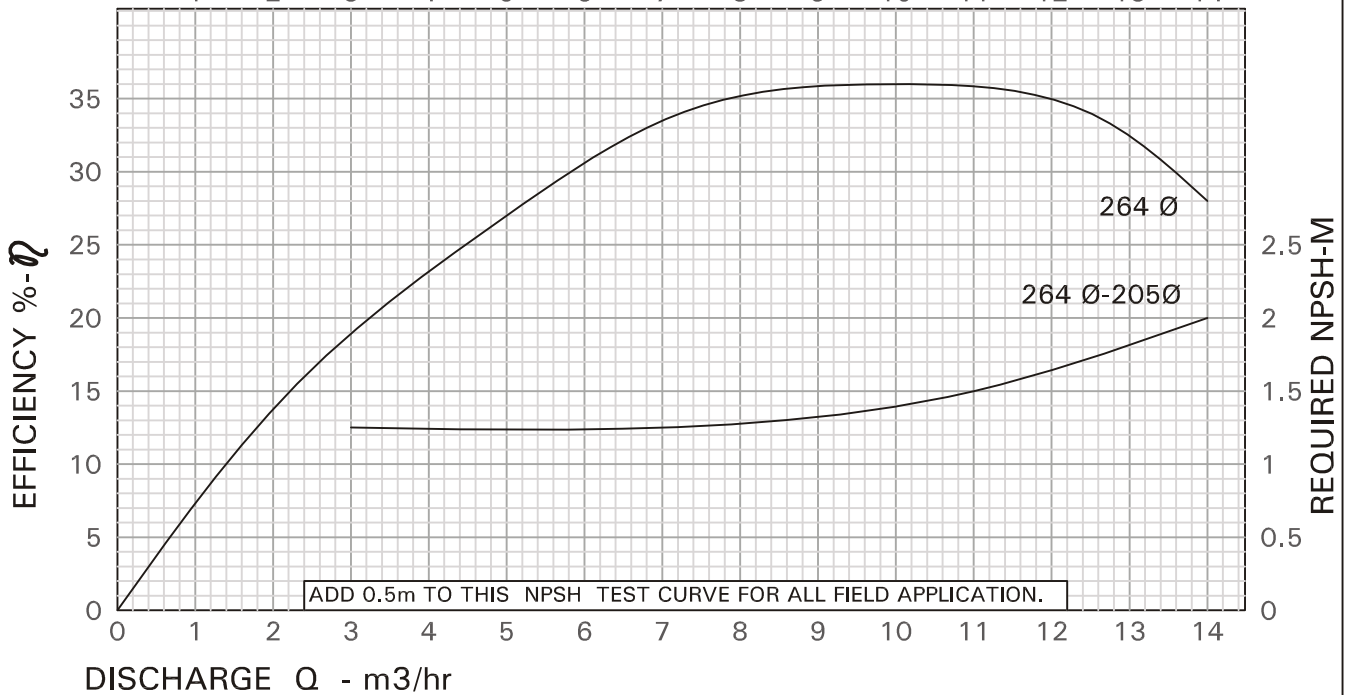
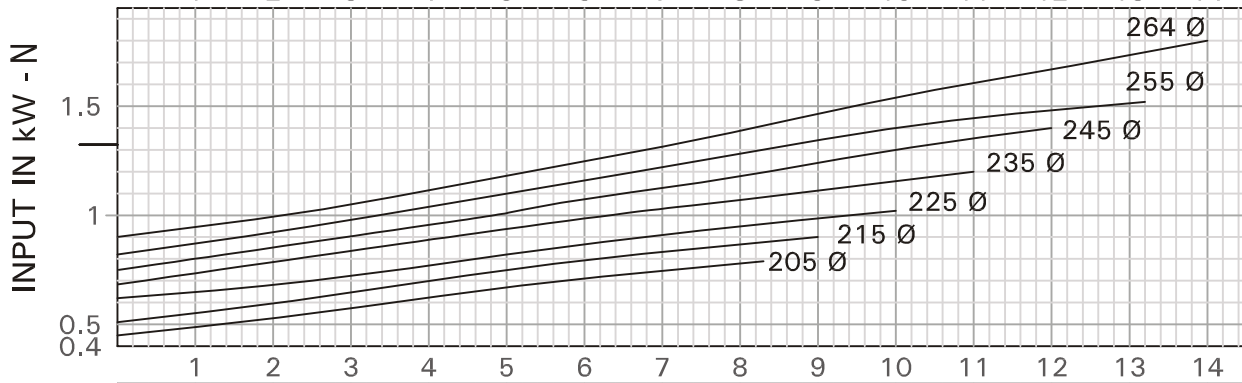
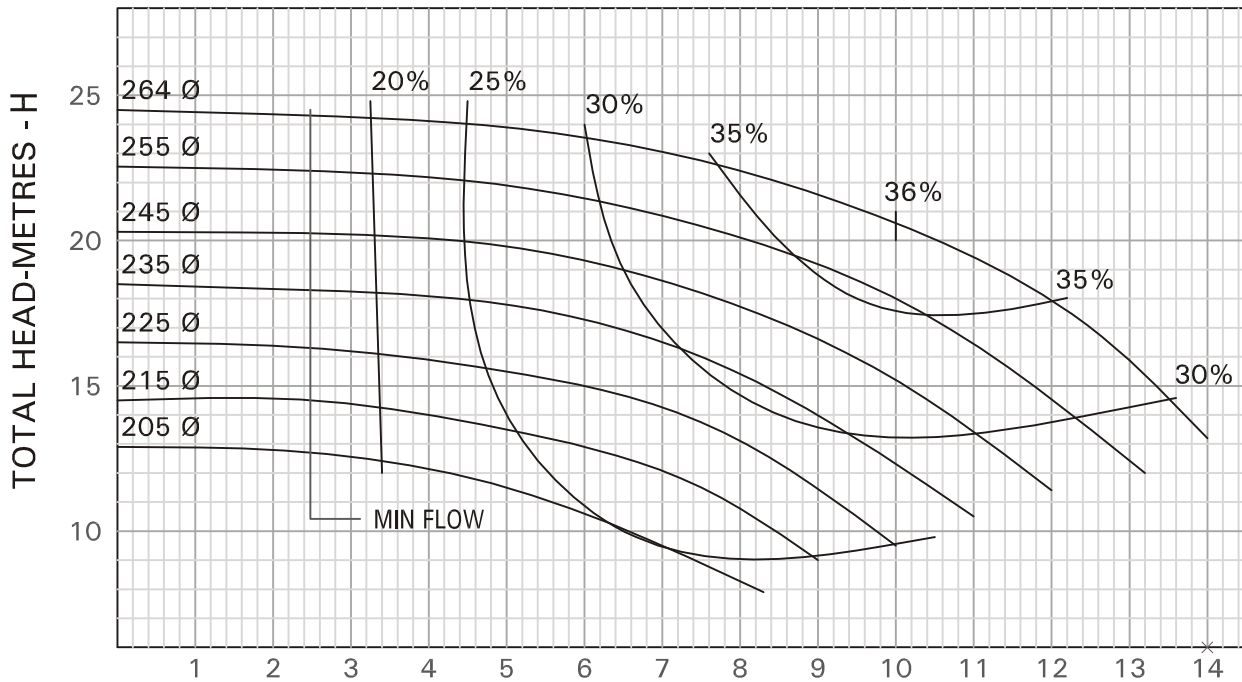

RECOMMENDED DELIVERY PIPE SIZE mm	40	50	65	
RECOMMENDED SUCTION PIPE SIZE mm	50		65	

# KIRLOSKAR BROTHERS LIMITED

NO. HD10205B0

## PERFORMANCE CURVE OF PUMP DB 40/13

SUC. 65 mm DEL 50mm

THIS CURVE RELATES TO LIQUID OF SP.GR. = 1.0

n = 1450<sup>rpm</sup>  
(NOMINAL)



Enriching Lives

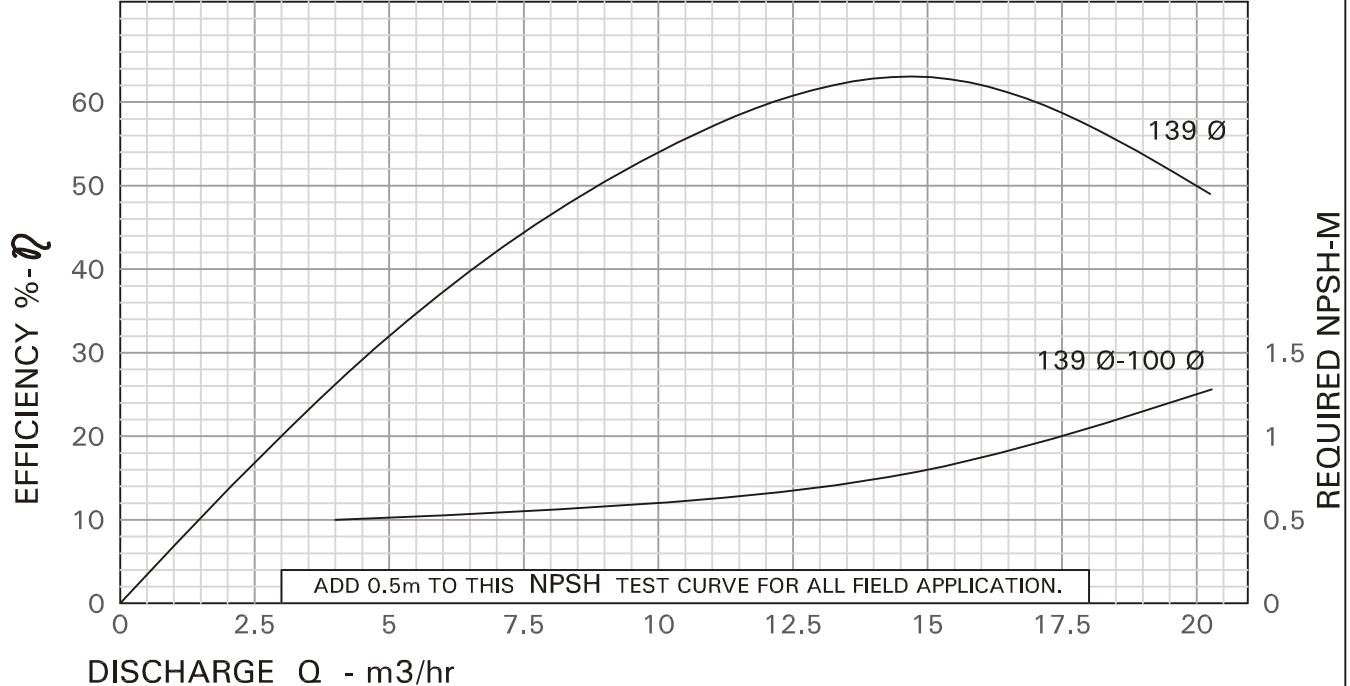
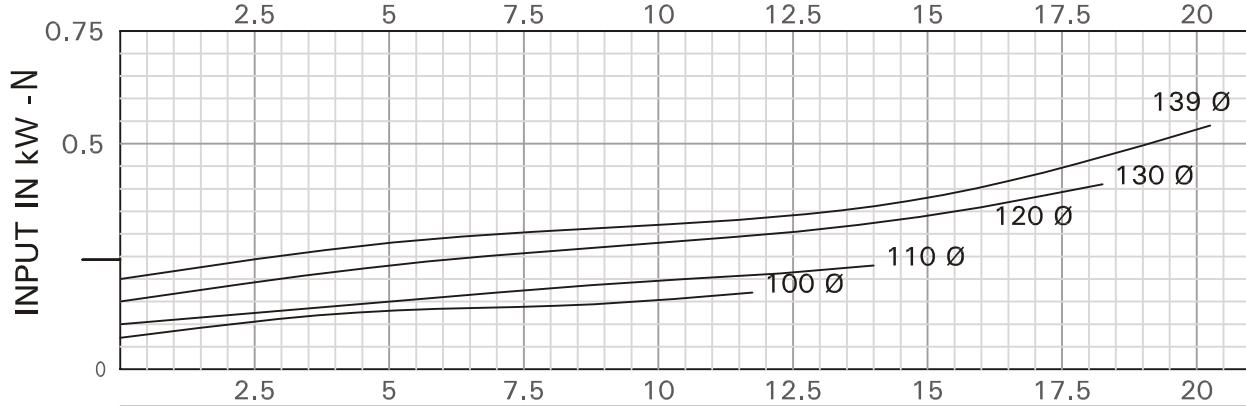
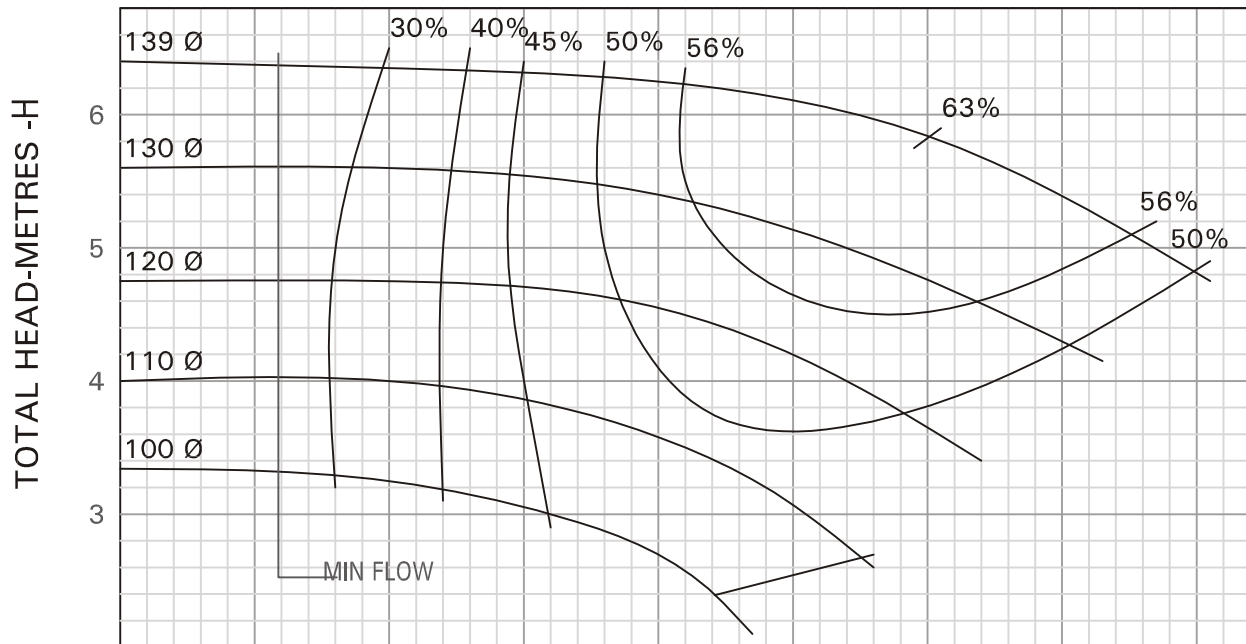

RECOMMENDED DELIVERY PIPE SIZE mm	50	65	80
RECOMMENDED SUCTION PIPE SIZE mm	65	80	

# KIRLOSKAR BROTHERS LIMITED

NO. HD10206B0

## PERFORMANCE CURVE OF PUMP DB 40/16

SUC. 65 mm DEL 40mm

THIS CURVE RELATES TO LIQUID OF SP.GR. = 1.0

n = 1450<sup>rpm</sup>  
(NOMINAL)



Enriching Lives

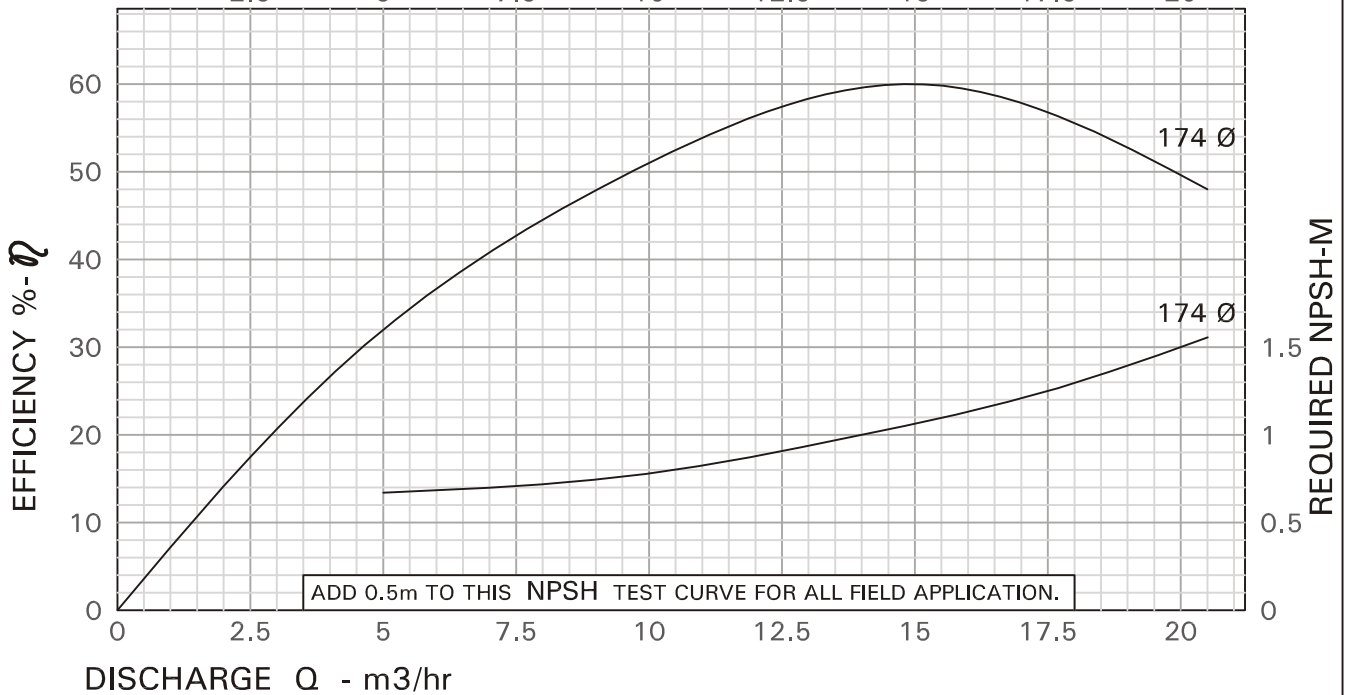
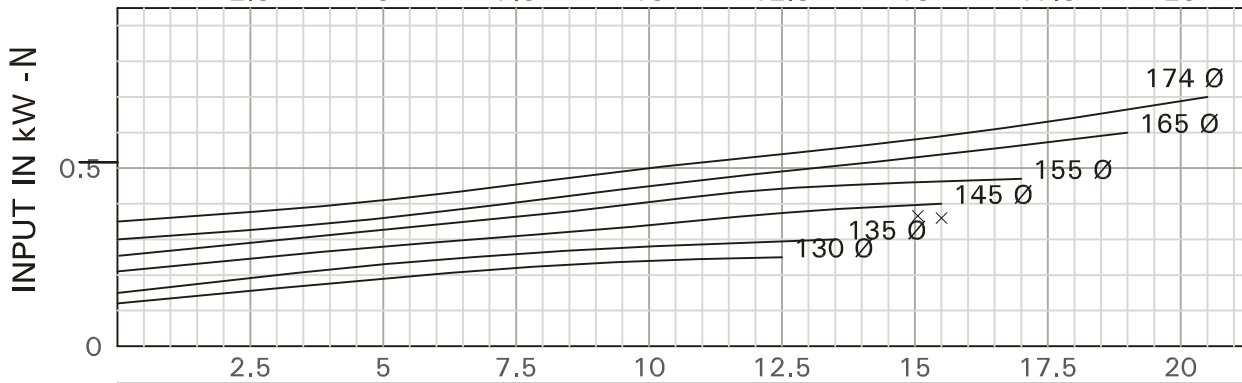
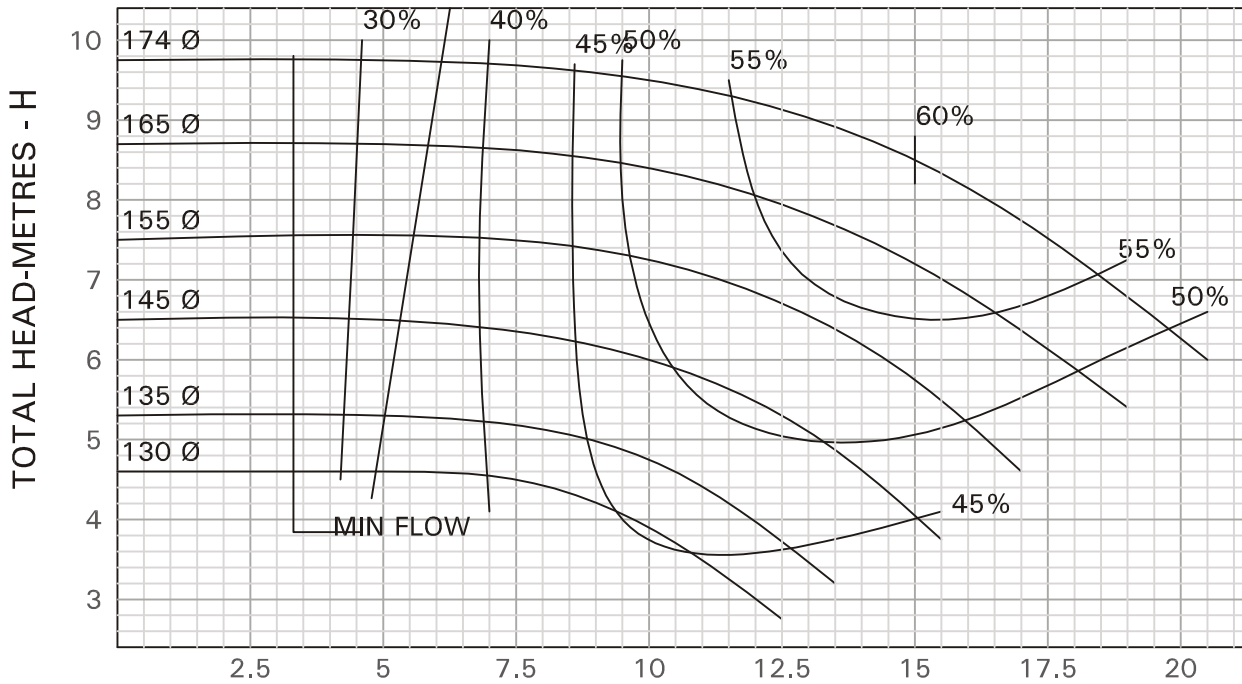

RECOMMENDED DELIVERY PIPE SIZE mm	50	65	80	
RECOMMENDED SUCTION PIPE SIZE mm	65	80		

# KIRLOSKAR BROTHERS LIMITED

NO. HD10207B0

## PERFORMANCE CURVE OF PUMP DB 40/20

SUC. 65 mm DEL 40mm

THIS CURVE RELATES TO LIQUID OF SP.GR. = 1.0

$n = 1450^{rpm}$   
(NOMINAL)



Enriching Lives

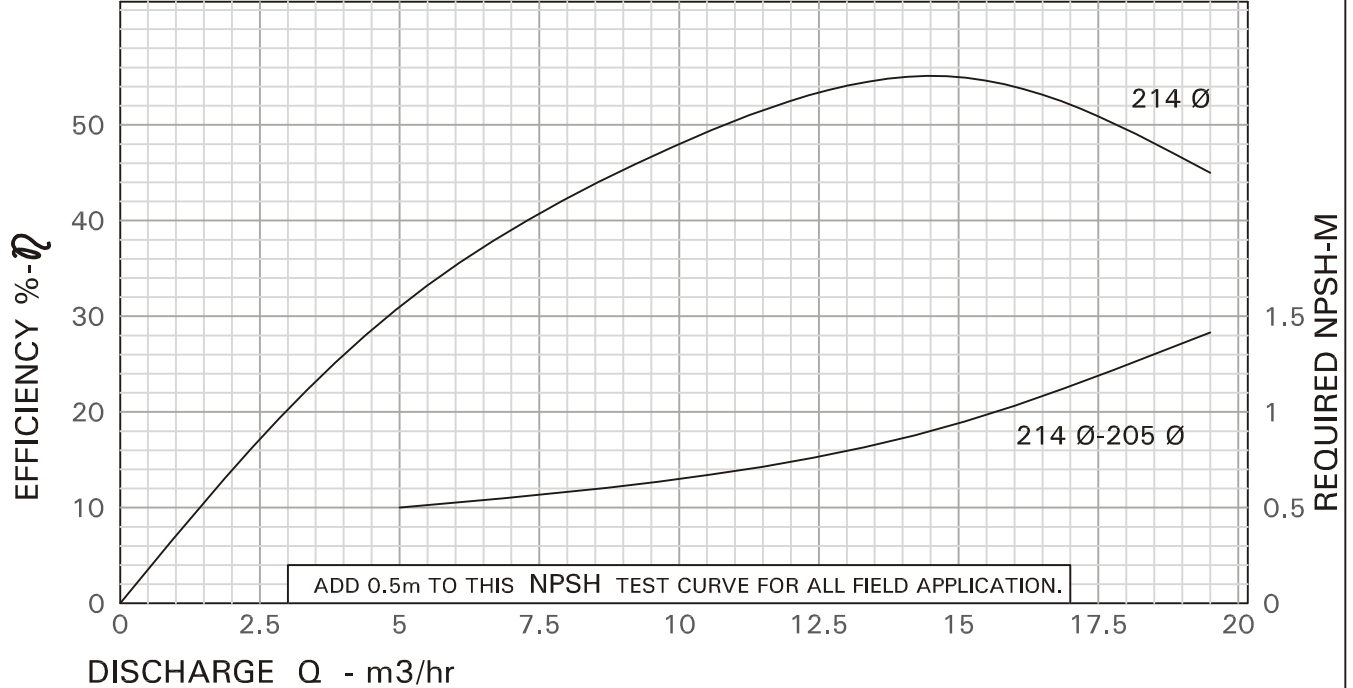
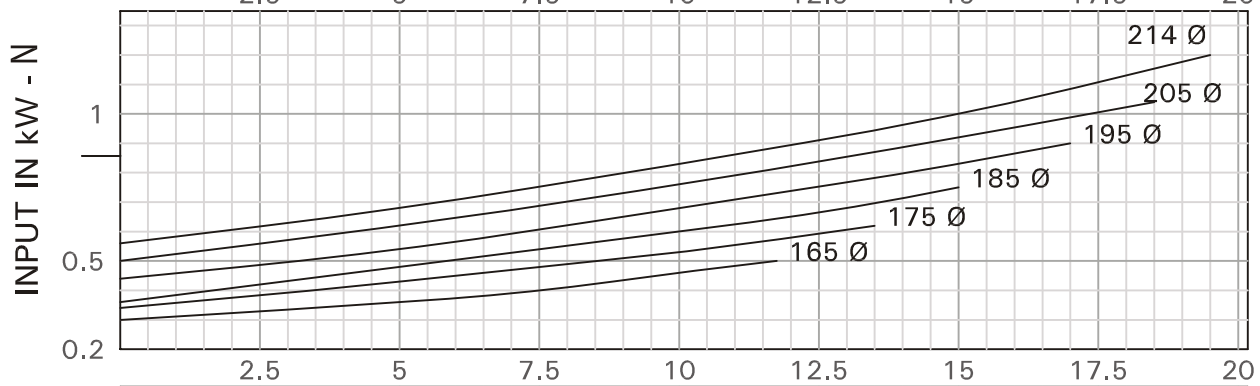
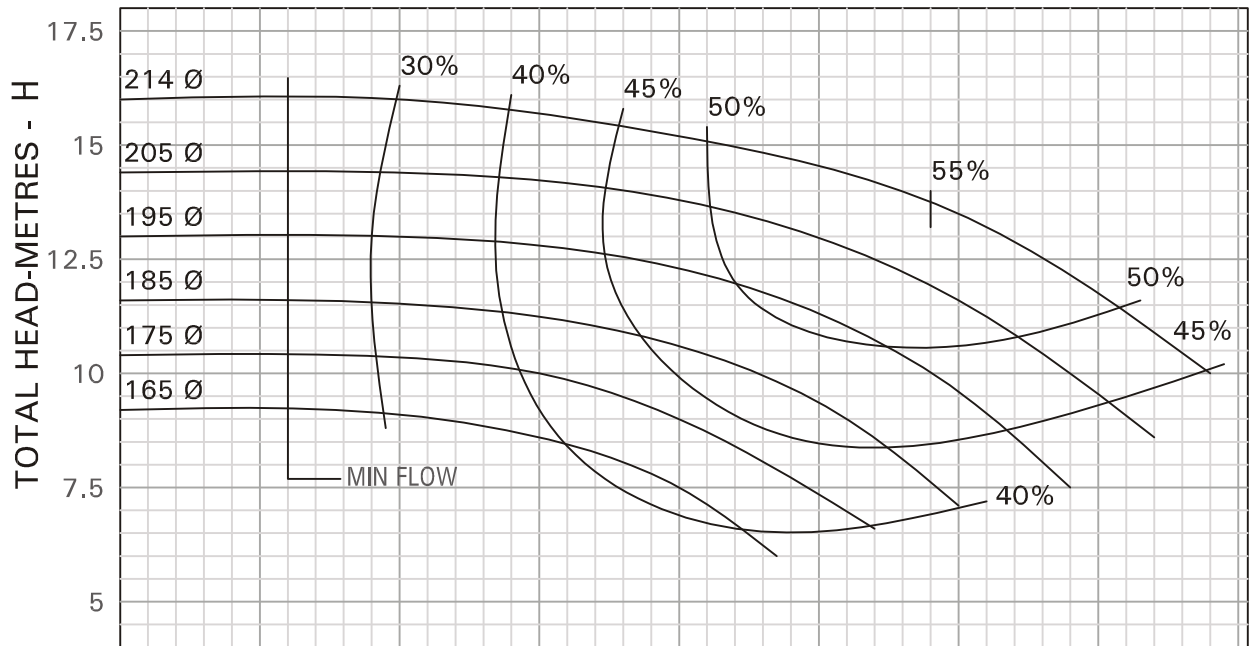

RECOMMENDED DELIVERY PIPE SIZE mm	50	65	80
RECOMMENDED SUCTION PIPE SIZE mm	65	80	

# KIRLOSKAR BROTHERS LIMITED

NO. HD10208B0

## PERFORMANCE CURVE OF PUMP DB 40/26

SUC. 65 mm DEL 50mm

THIS CURVE RELATES TO LIQUID OF SP.GR. = 1.0

n = 1450<sup>rpm</sup>  
(NOMINAL)



Enriching Lives

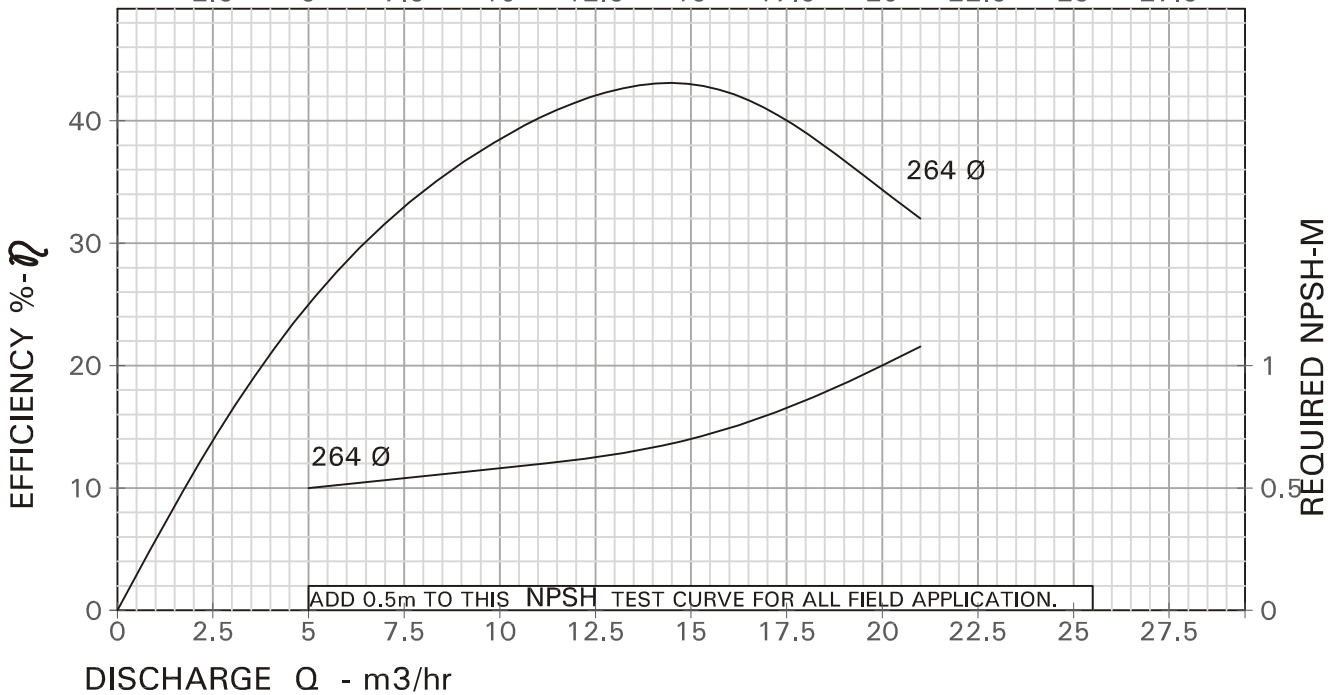
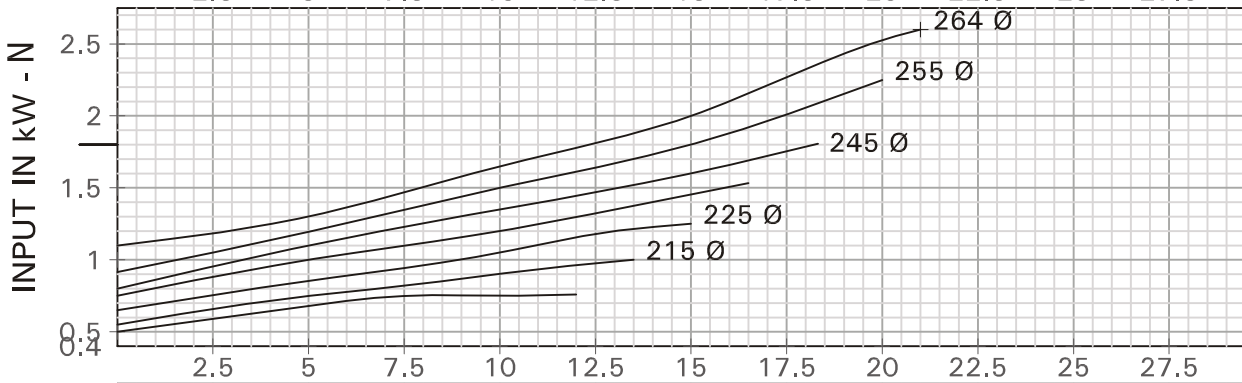
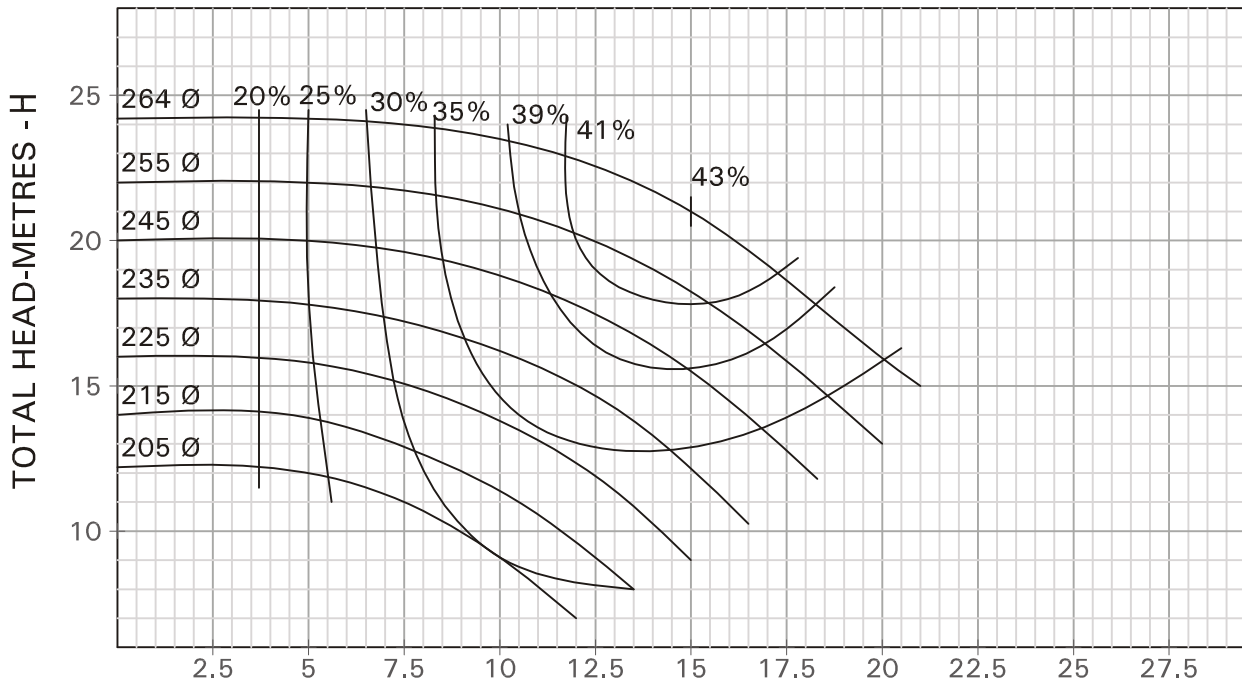

RECOMMENDED DELIVERY PIPE SIZE mm	
RECOMMENDED SUCTION PIPE SIZE mm	

# KIRLOSKAR BROTHERS LIMITED

NO. HD10209B0

## PERFORMANCE CURVE OF PUMP DB 50/13

SUC. 65 mm DEL. 50mm

THIS CURVE RELATES TO LIQUID OF SP.GR. = 1.0

n = 1450 rpm  
(NOMINAL)



Enriching Lives

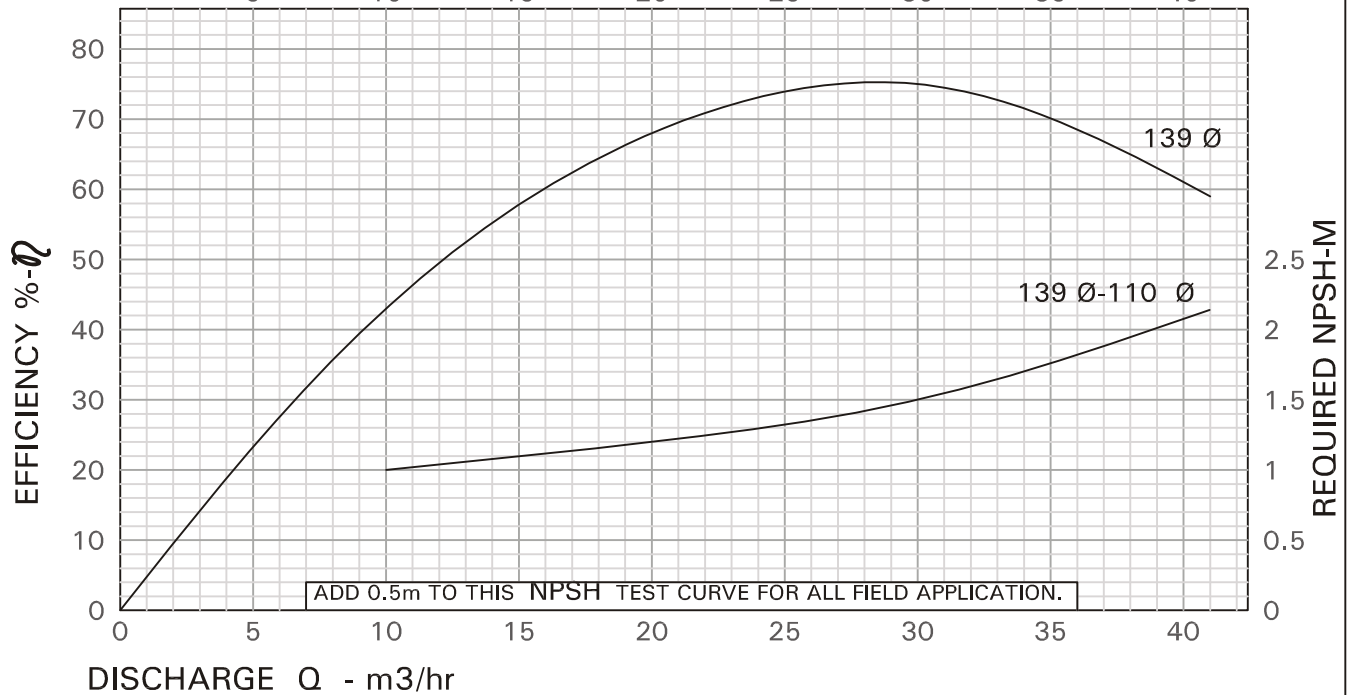
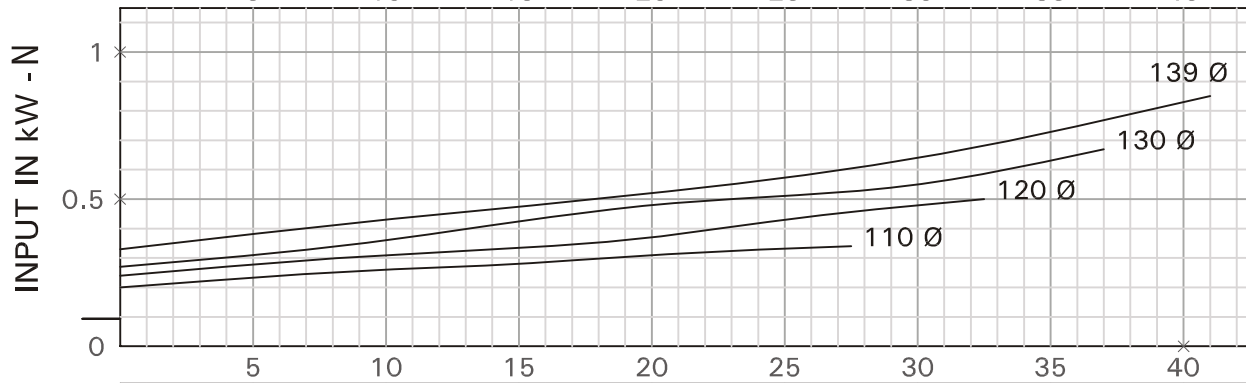
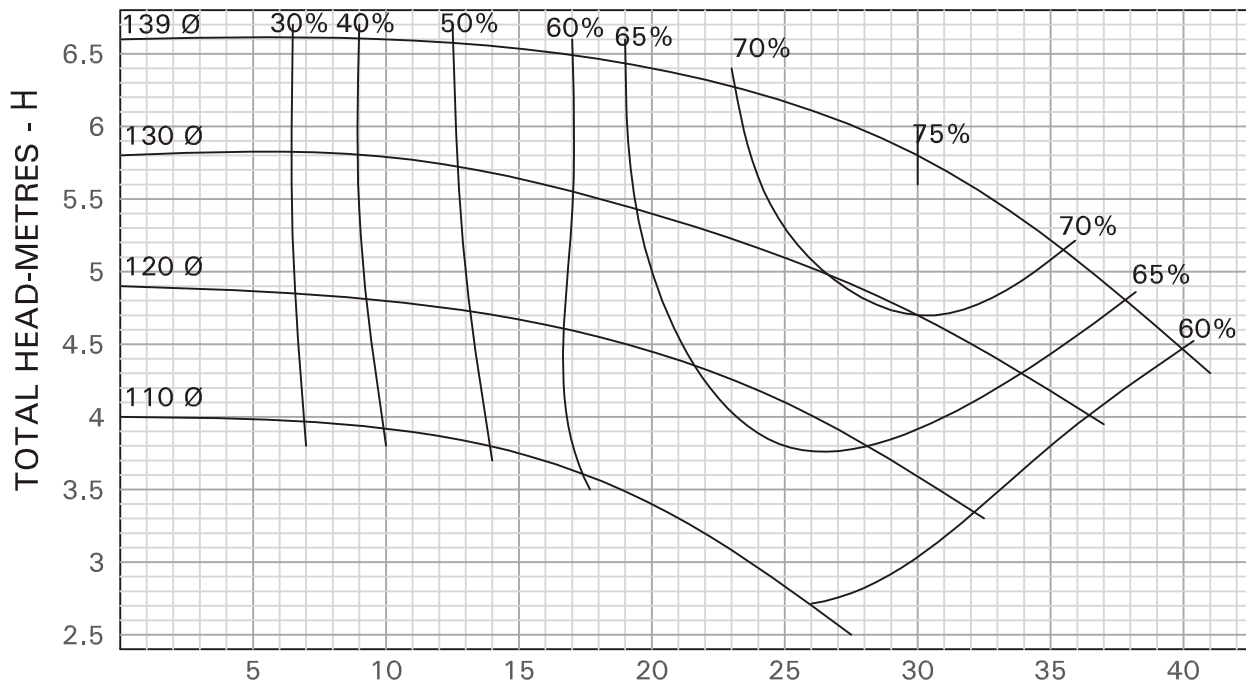

RECOMMENDED DELIVERY PIPE SIZE mm	50	65	80	100	
RECOMMENDED SUCTION PIPE SIZE mm		80		100	

**KIRLOSKAR BROTHERS LIMITED**

NO. HD10210B0

**PERFORMANCE CURVE OF PUMP DB 50/16**

SUC. 65 mm DEL 50mm

THIS CURVE RELATES TO LIQUID OF SP.GR. = 1.0

n = 1450 rpm  
(NOMINAL)



Enriching Lives

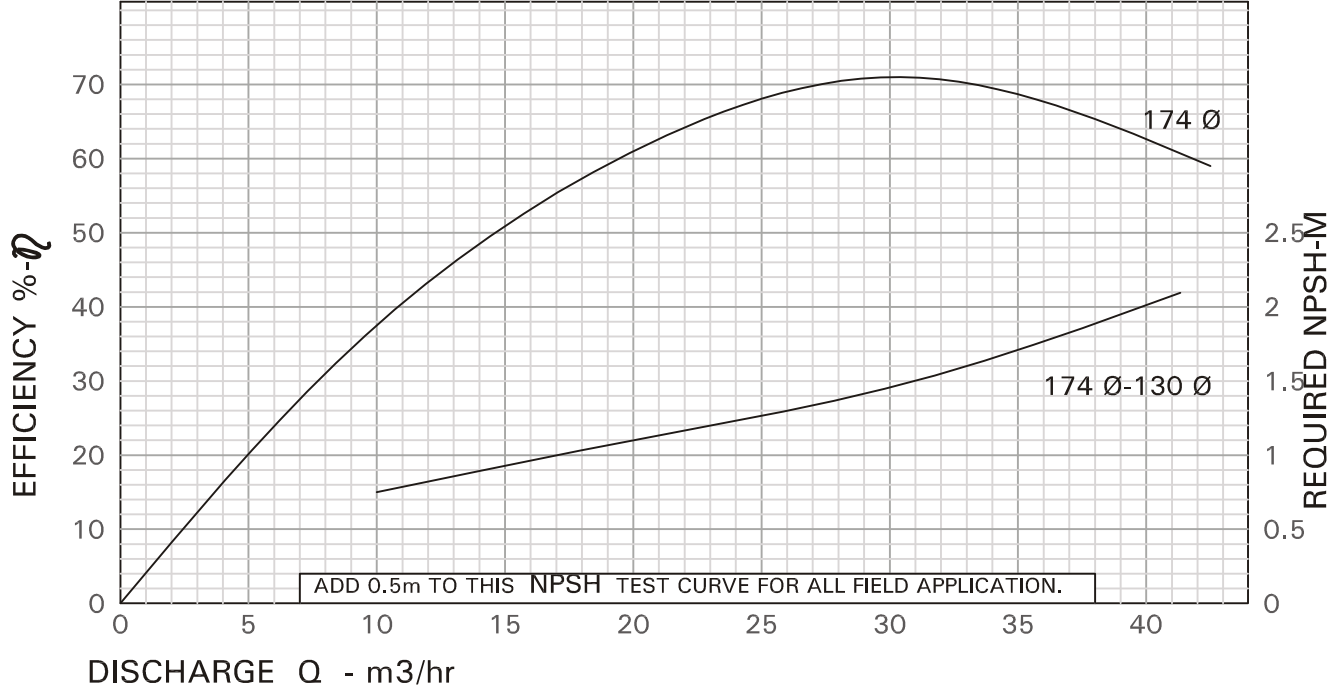
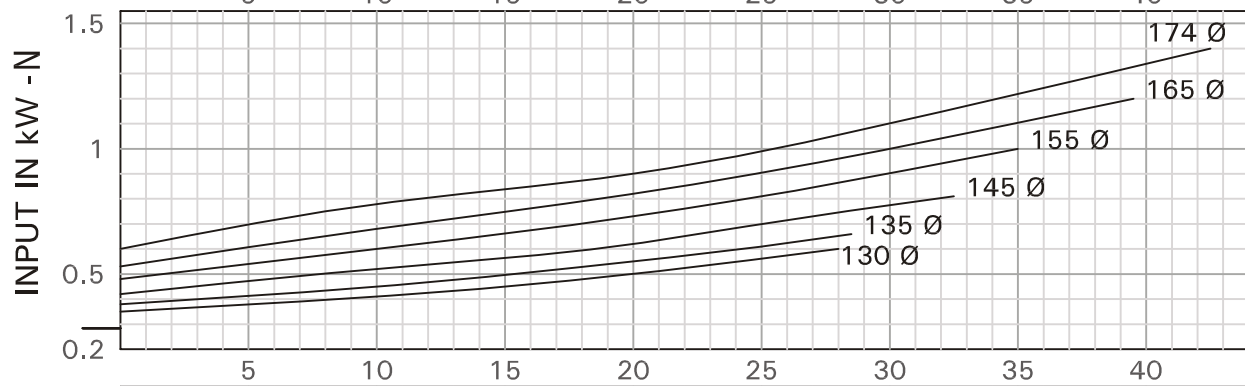
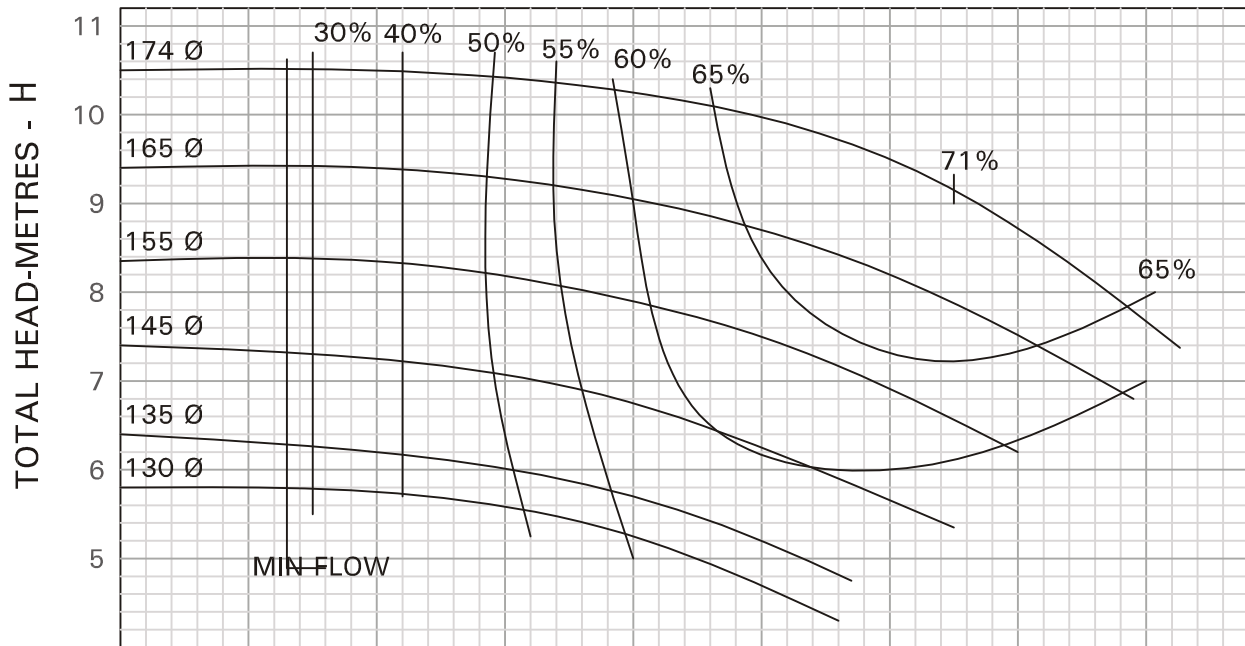

RECOMMENDED DELIVERY PIPE SIZE mm	50	65	80	100
RECOMMENDED SUCTION PIPE SIZE mm	65		80	100

# KIRLOSKAR BROTHERS LIMITED

NO. HD10211B0

## PERFORMANCE CURVE OF PUMP DB 50/20

SUC. 65 mm DEL 50mm

THIS CURVE RELATES TO LIQUID OF SP.GR. = 1.0

$n = 1450^{rpm}$   
(NOMINAL)



Enriching Lives

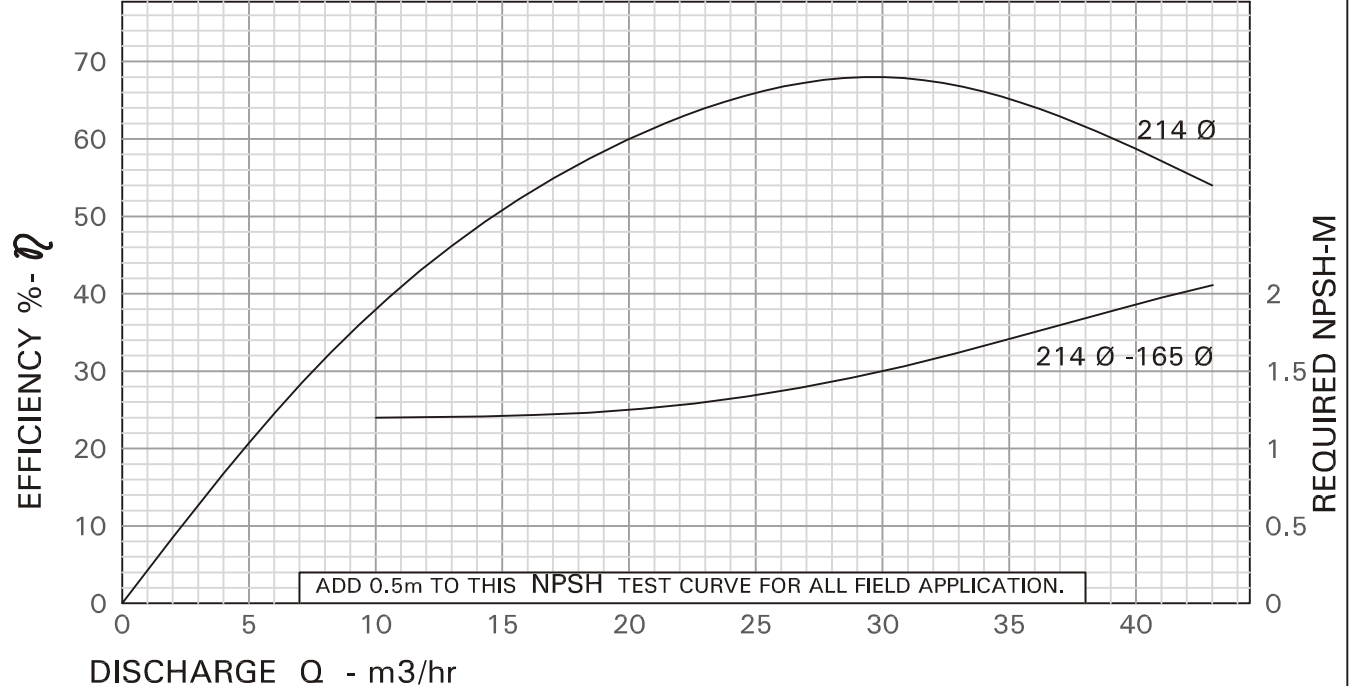
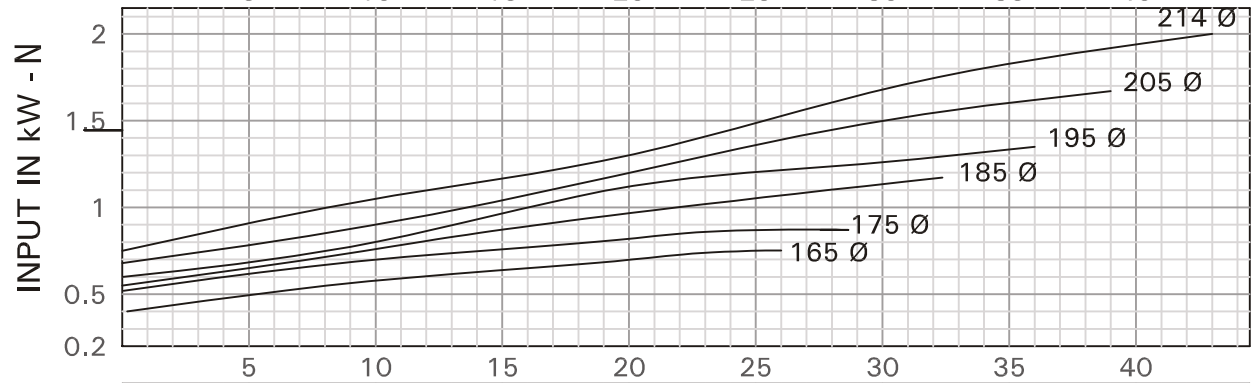
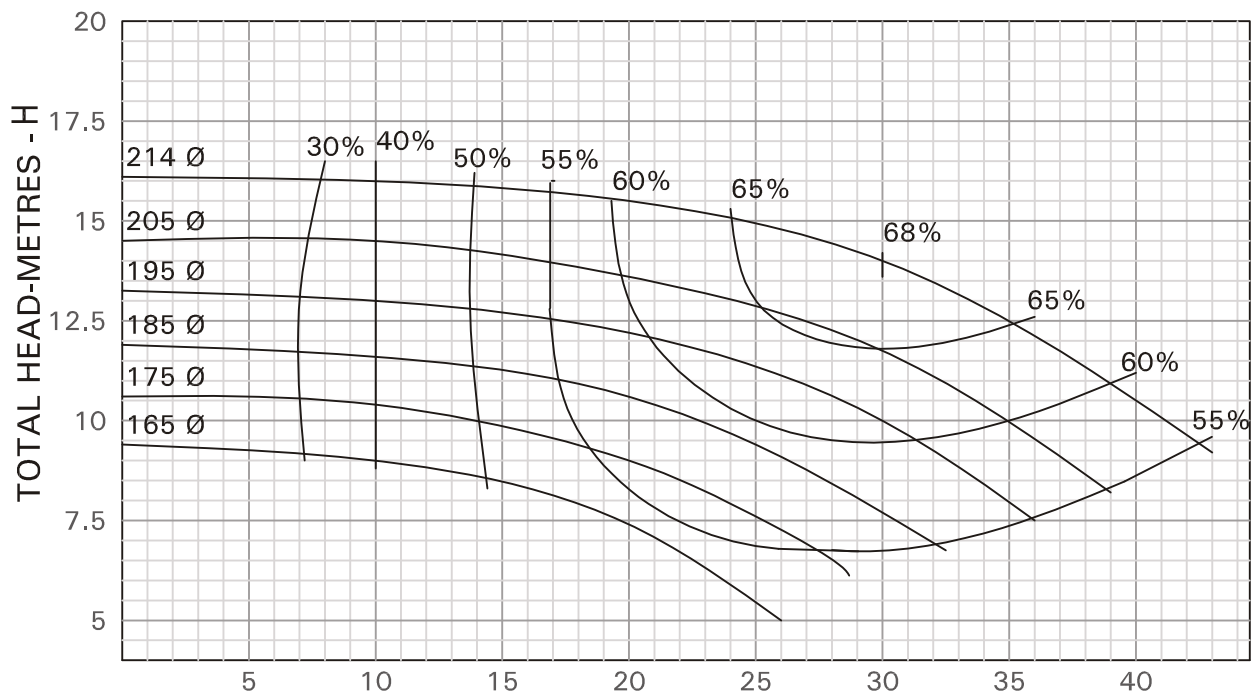

RECOMMENDED DELIVERY PIPE SIZE mm	50	65	80	100	
RECOMMENDED SUCTION PIPE SIZE mm	80		100		

# KIRLOSKAR BROTHERS LIMITED

NO. HD10212B0

## PERFORMANCE CURVE OF PUMP DB 50/26

SUC. 65 mm DEL 50mm

THIS CURVE RELATES TO LIQUID OF SP.GR. = 1.0

n = 1450 rpm  
(NOMINAL)



Enriching Lives

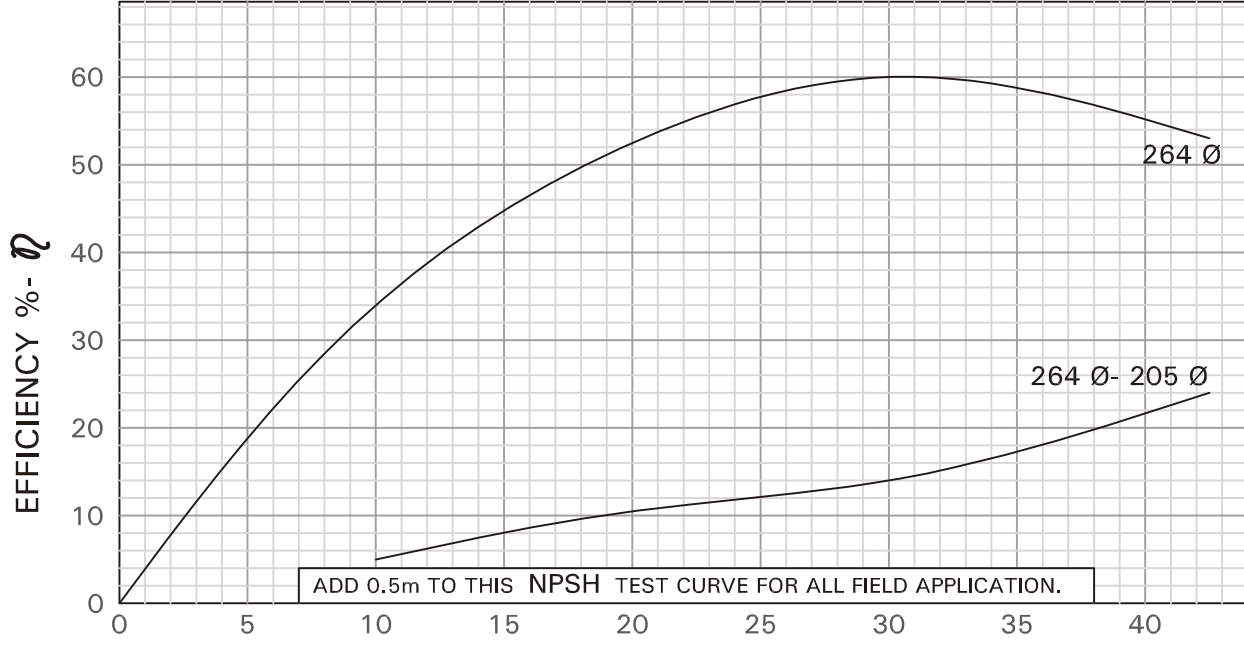
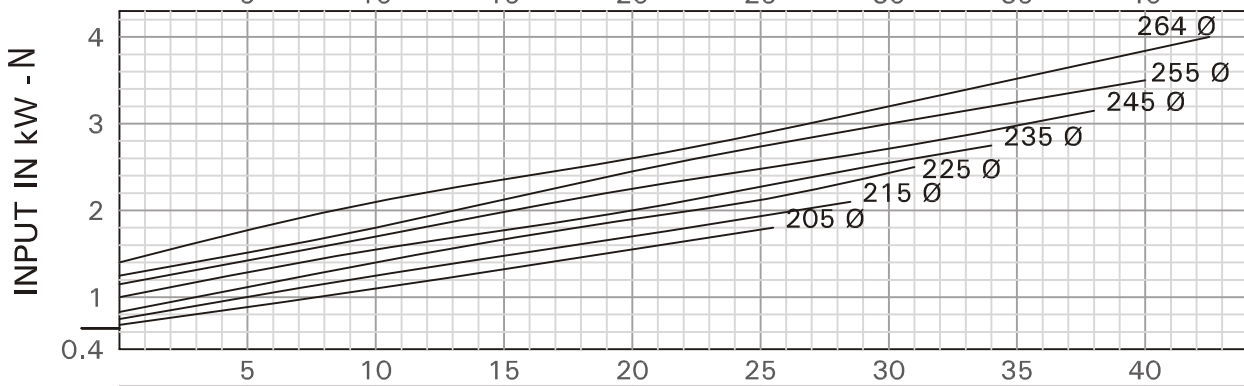
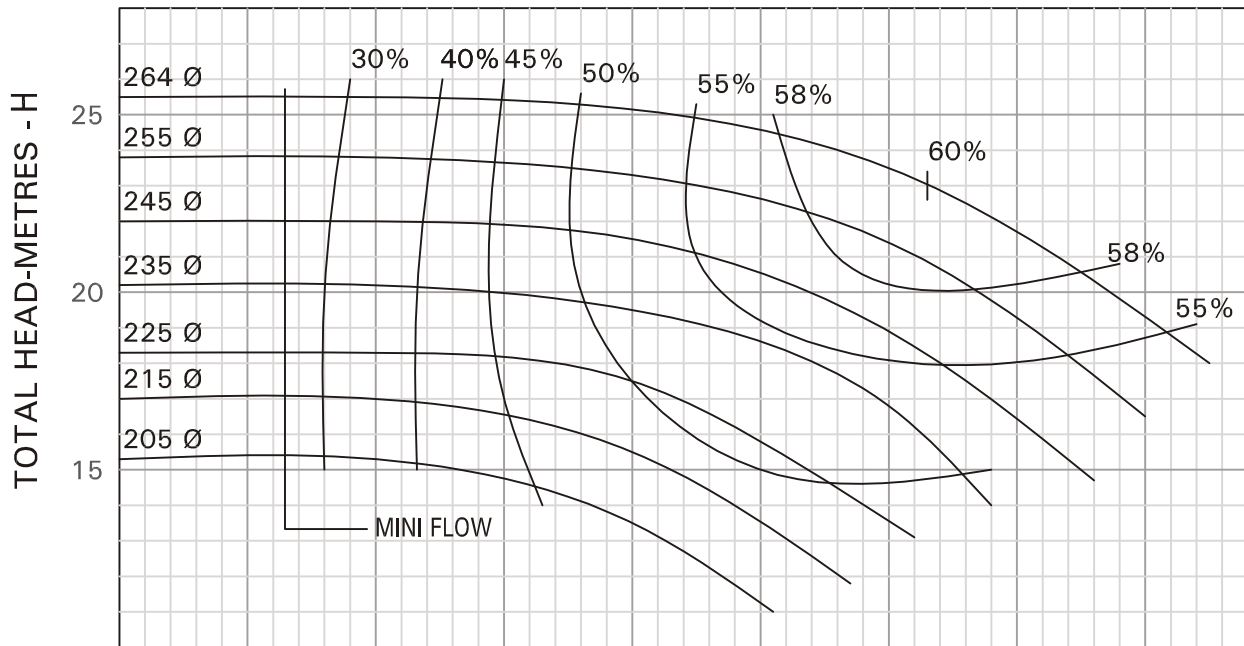

RECOMMENDED DELIVERY PIPE SIZE mm	50	65	80	100	
RECOMMENDED SUCTION PIPE SIZE mm	80		100		

# KIRLOSKAR BROTHERS LIMITED

NO. HD10232AB00



## PERFORMANCE CURVE OF PUMP DB 50/32K

SUC. 65 mm DEL 50 mm

THIS CURVE RELATES TO LIQUID OF SP.GR. = 1.0

n = 1450 rpm  
(NOMINAL)

Enriching Lives

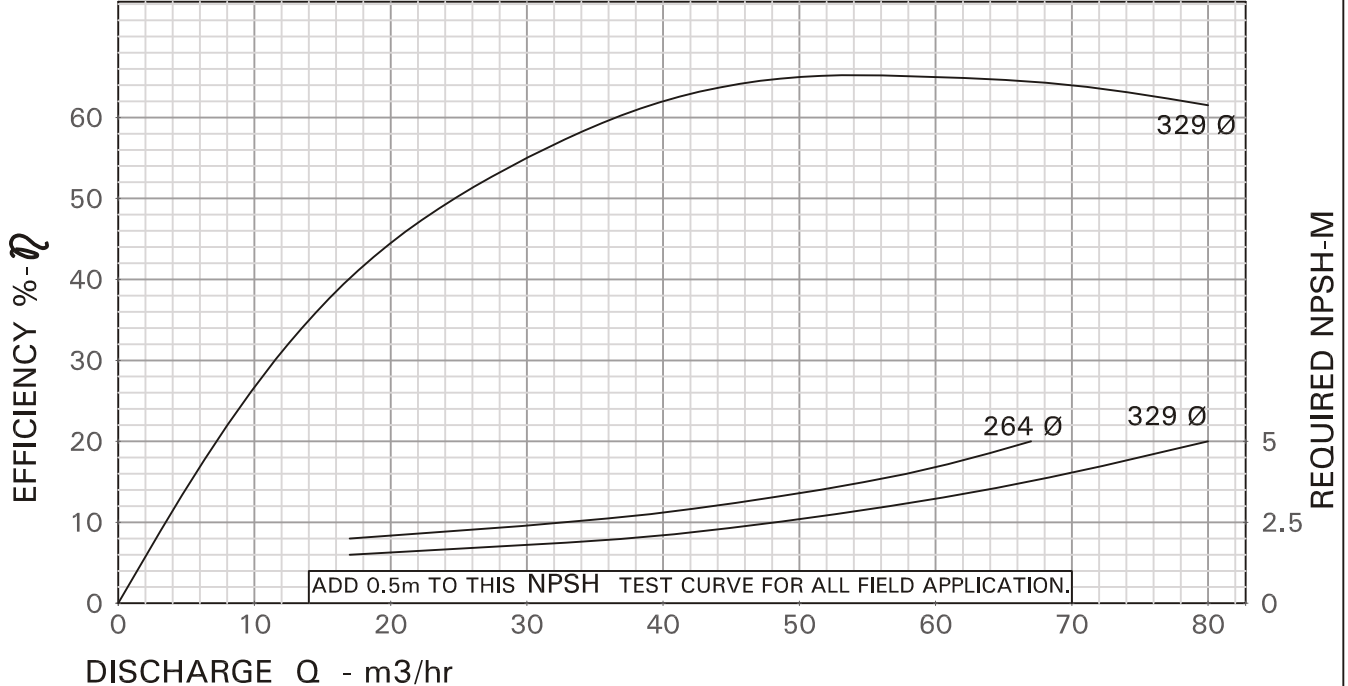
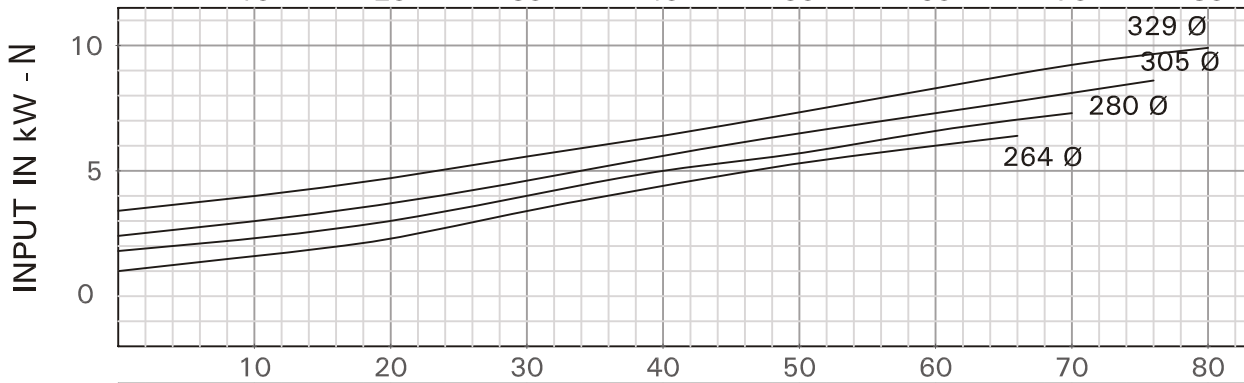
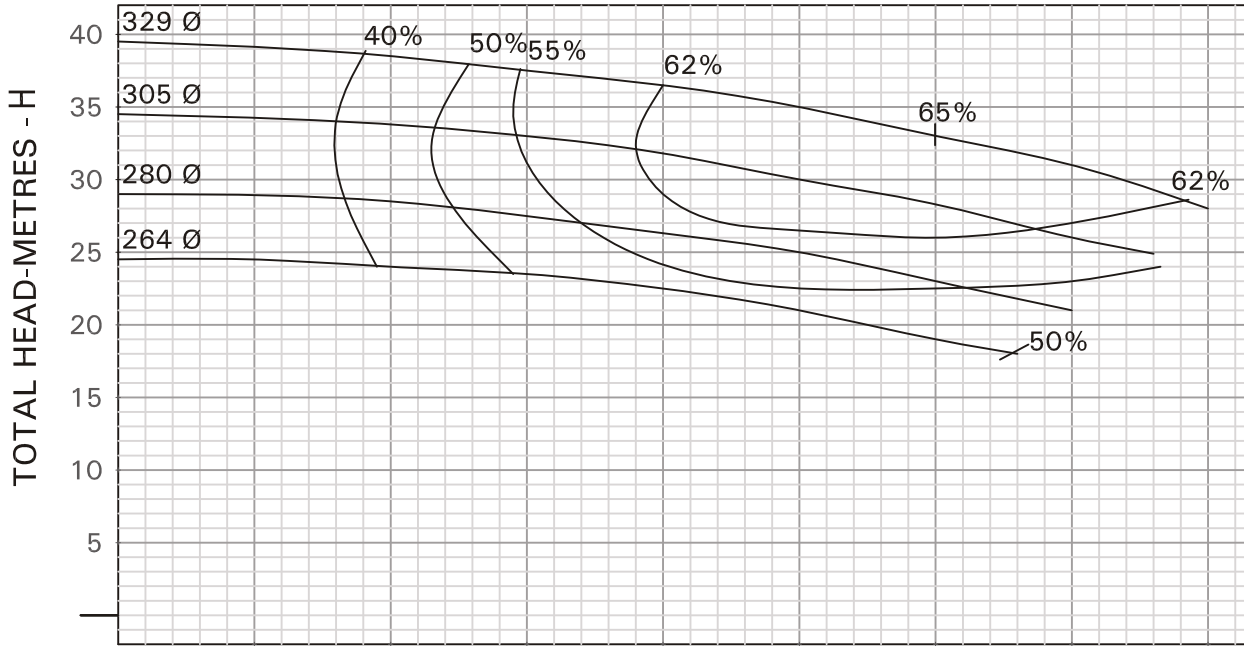

RECOMMENDED DELIVERY PIPE SIZE mm	65	80	
RECOMMENDED SUCTION PIPE SIZE mm	80	100	

# KIRLOSKAR BROTHERS LIMITED

NO. HD10213B0

## PERFORMANCE CURVE OF PUMP DB 65/13

SUC. 80 mm DEL. 65 mm

THIS CURVE RELATES TO LIQUID OF SP.GR. = 1.0

n = 1450 rpm  
(NOMINAL)



Enriching Lives

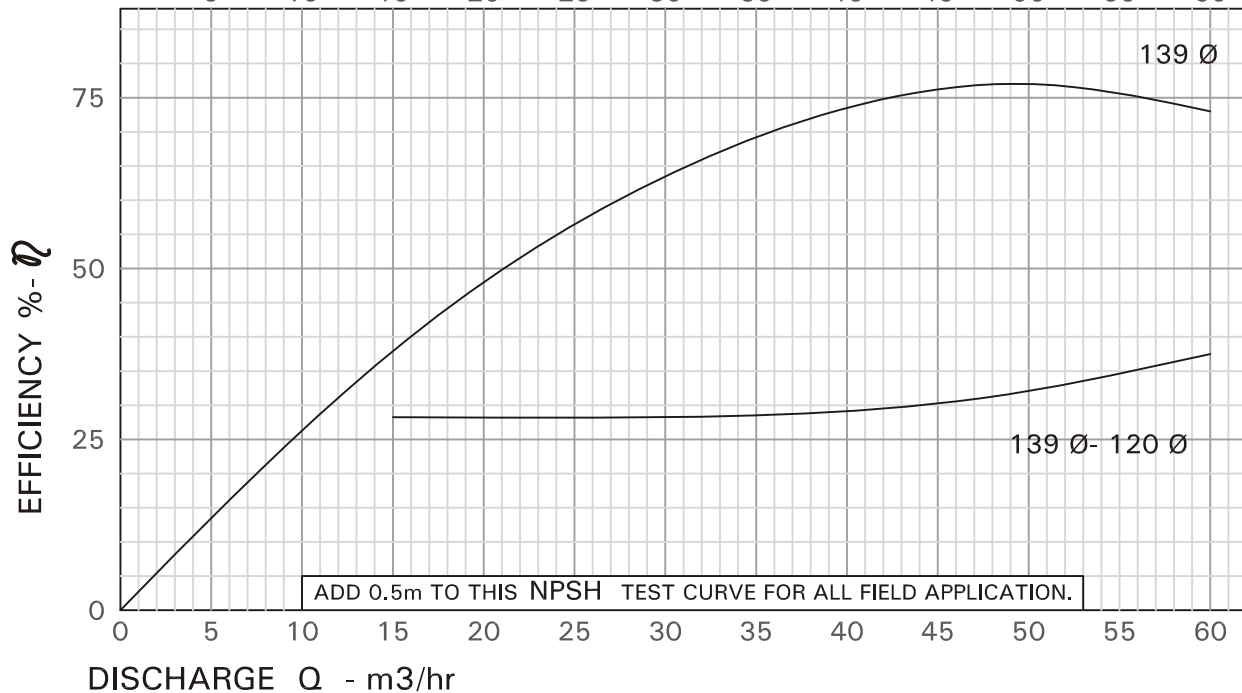
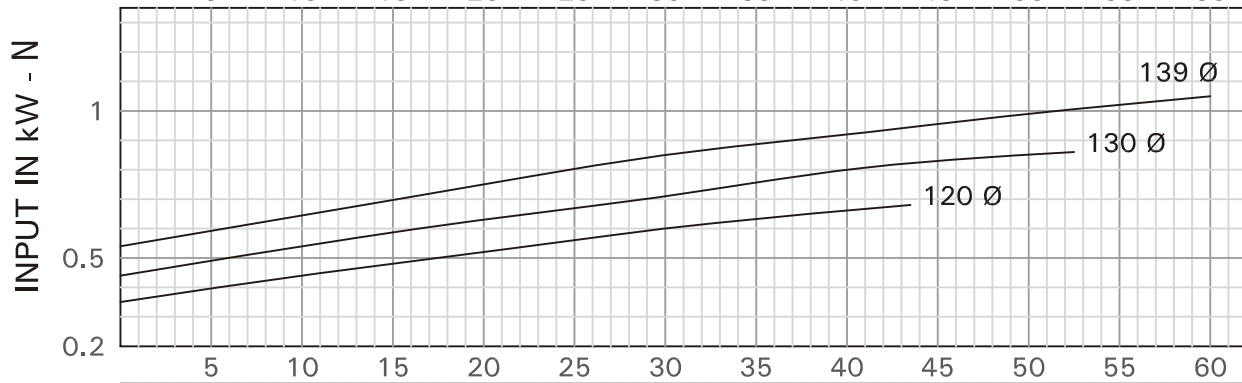
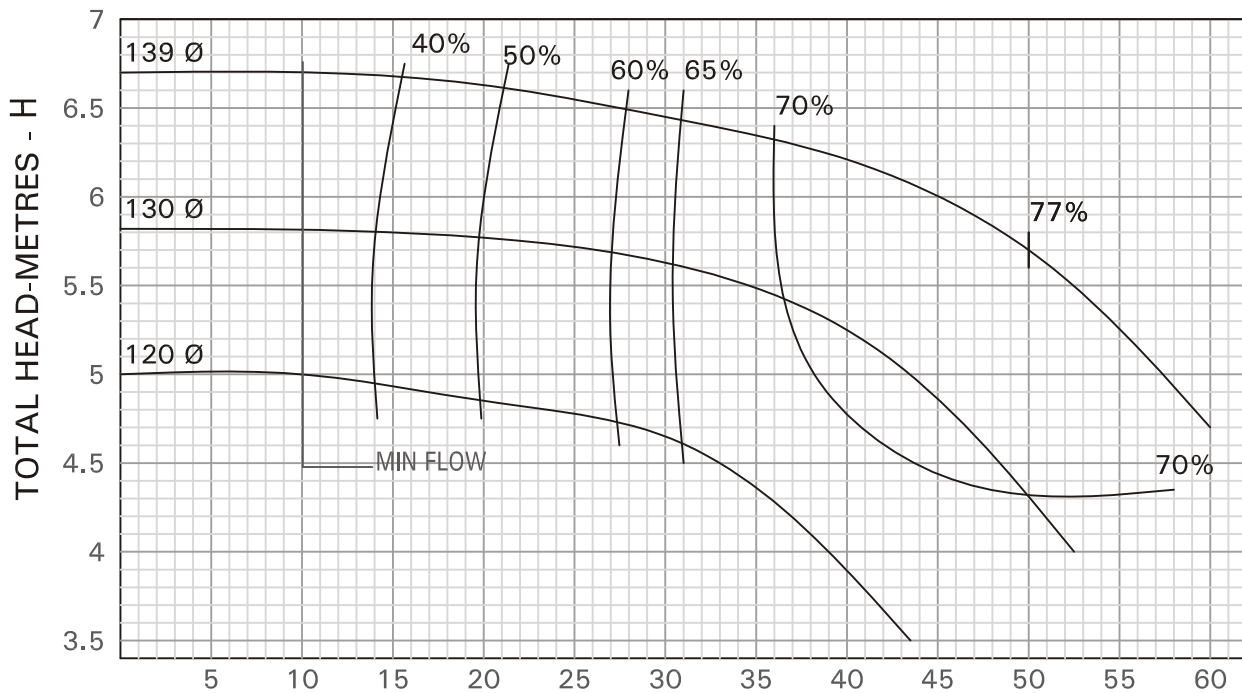

RECOMMENDED DELIVERY PIPE SIZE mm	80	100	125
RECOMMENDED SUCTION PIPE SIZE mm	100	125	

# KIRLOSKAR BROTHERS LIMITED

NO. HD10214B0

## PERFORMANCE CURVE OF PUMP DB 65/16

SUC. 80 mm DEL 65mm

THIS CURVE RELATES TO LIQUID OF SP.GR. = 1.0

n = 1450 rpm  
(NOMINAL)



Enriching Lives

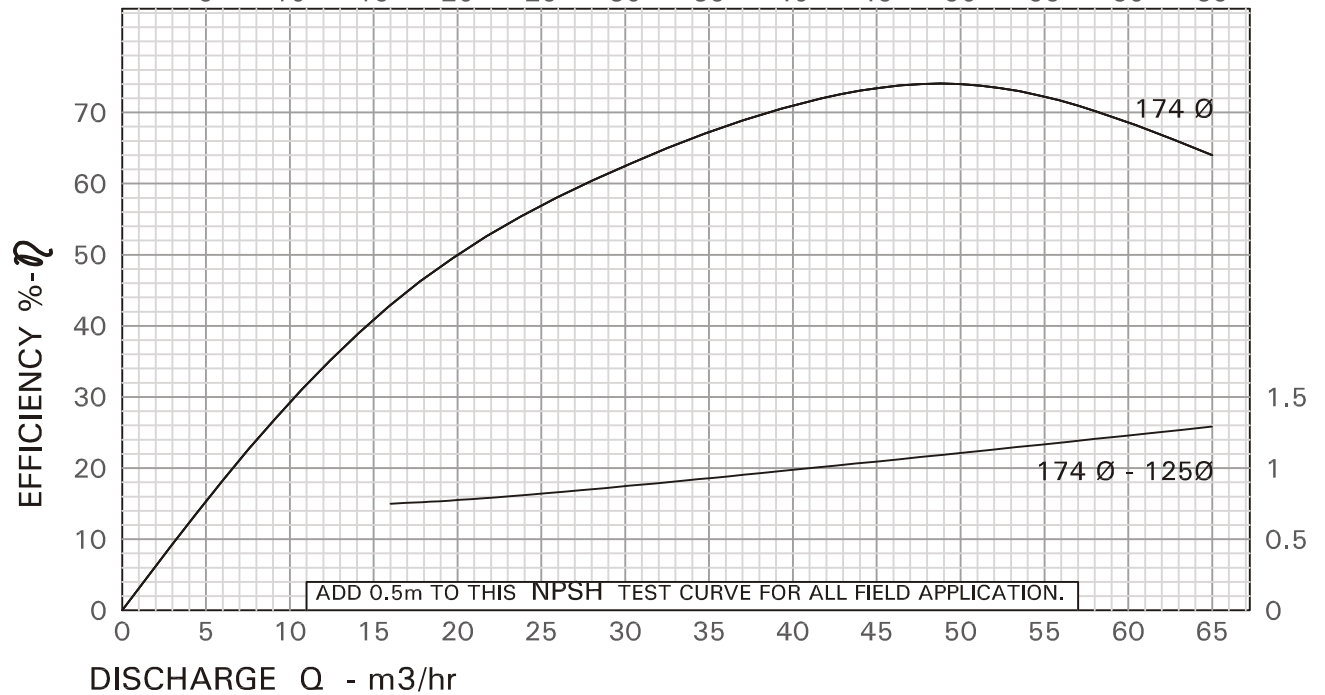
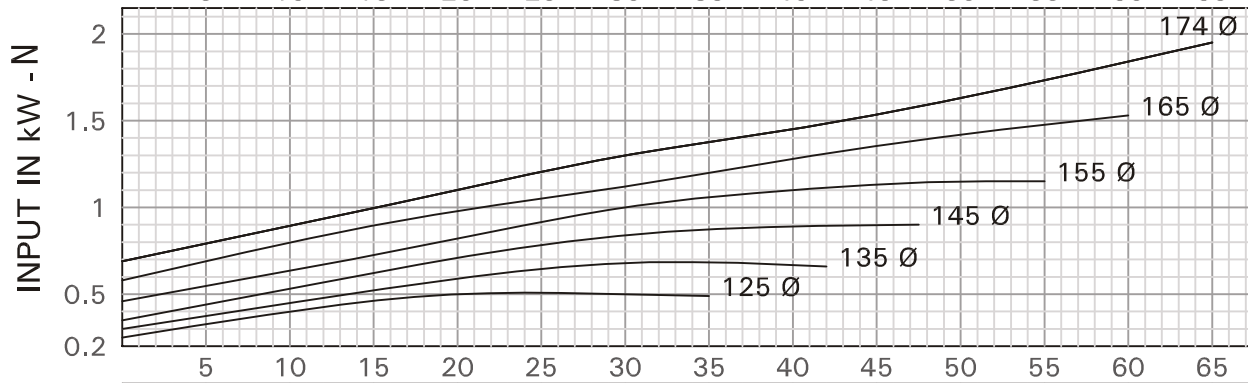
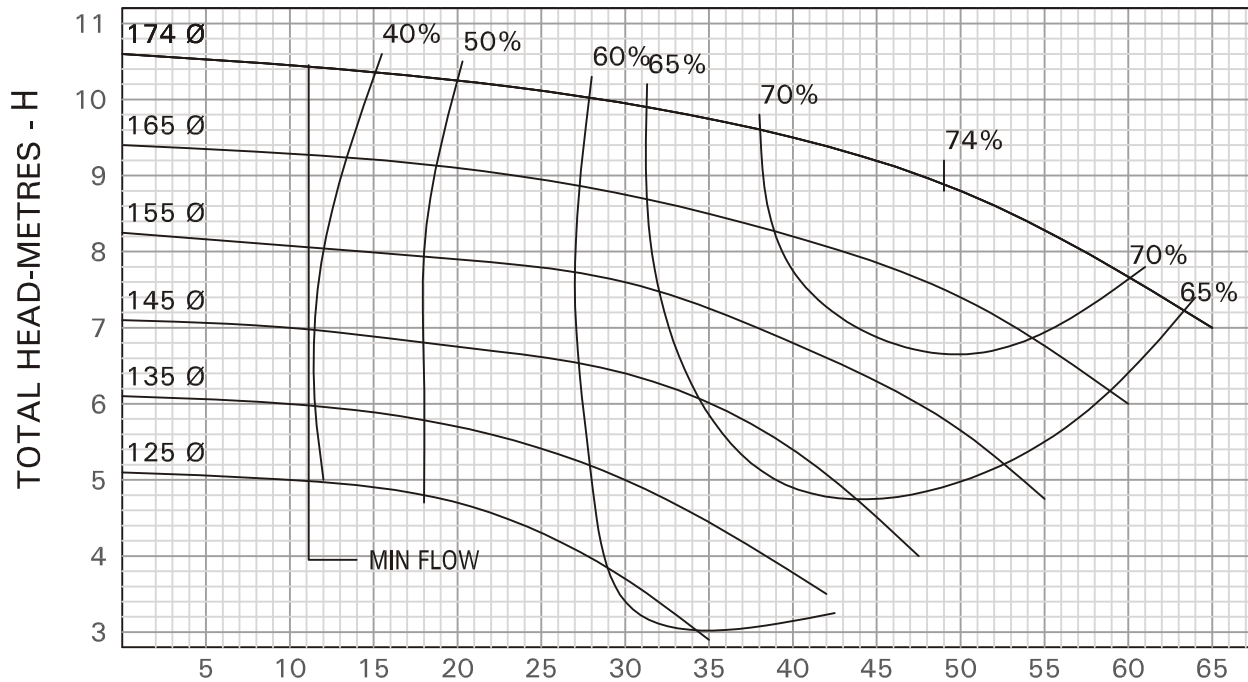

RECOMMENDED DELIVERY PIPE SIZE mm	65	80	100	125	
RECOMMENDED SUCTION PIPE SIZE mm	100		125		

# KIRLOSKAR BROTHERS LIMITED

NO. HD10215B0

## PERFORMANCE CURVE OF PUMP DB 65/20

SUC. 80 mm DEL 65 mm

THIS CURVE RELATES TO LIQUID OF SP.GR. = 1.0

n = 1450 rpm  
(NOMINAL)



Enriching Lives

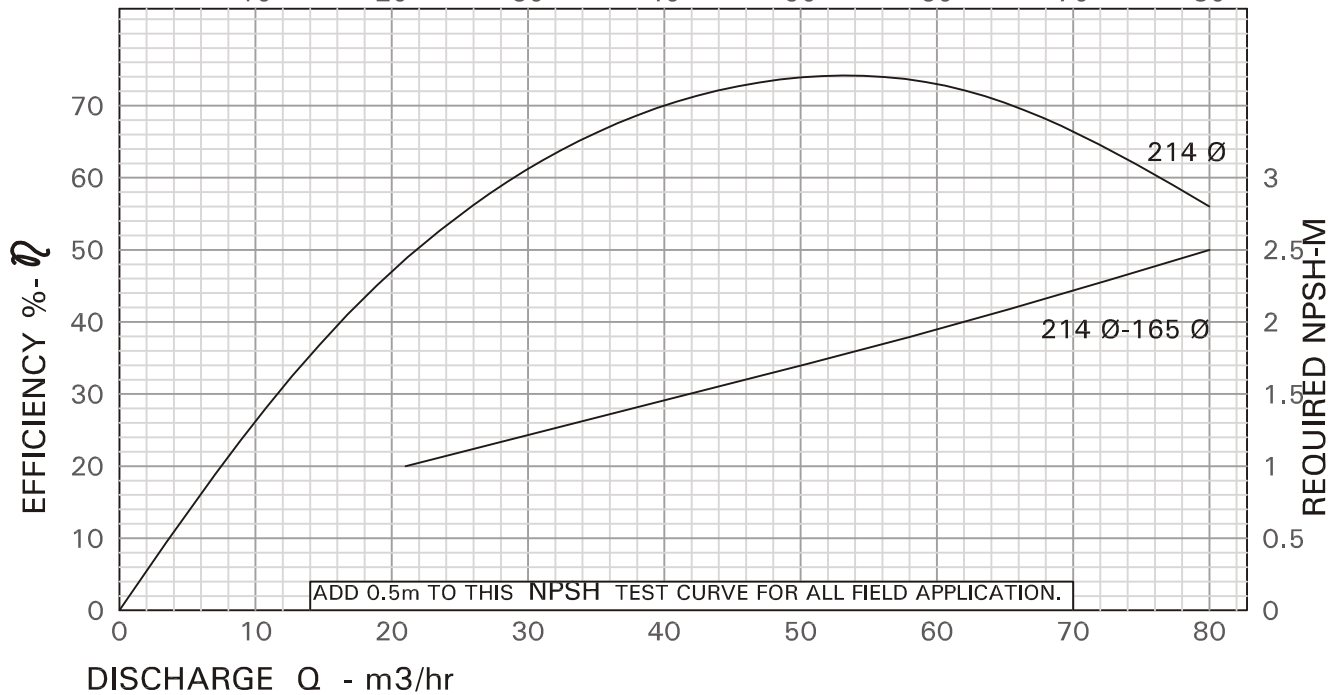
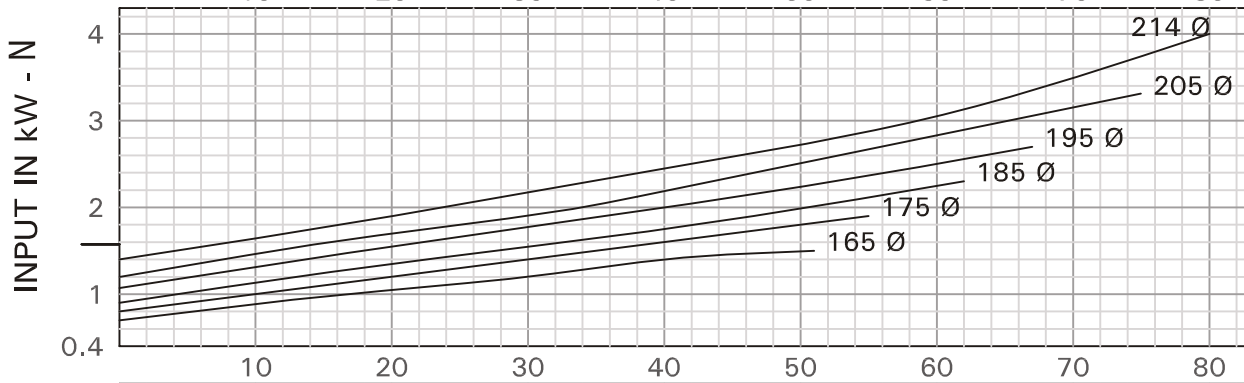
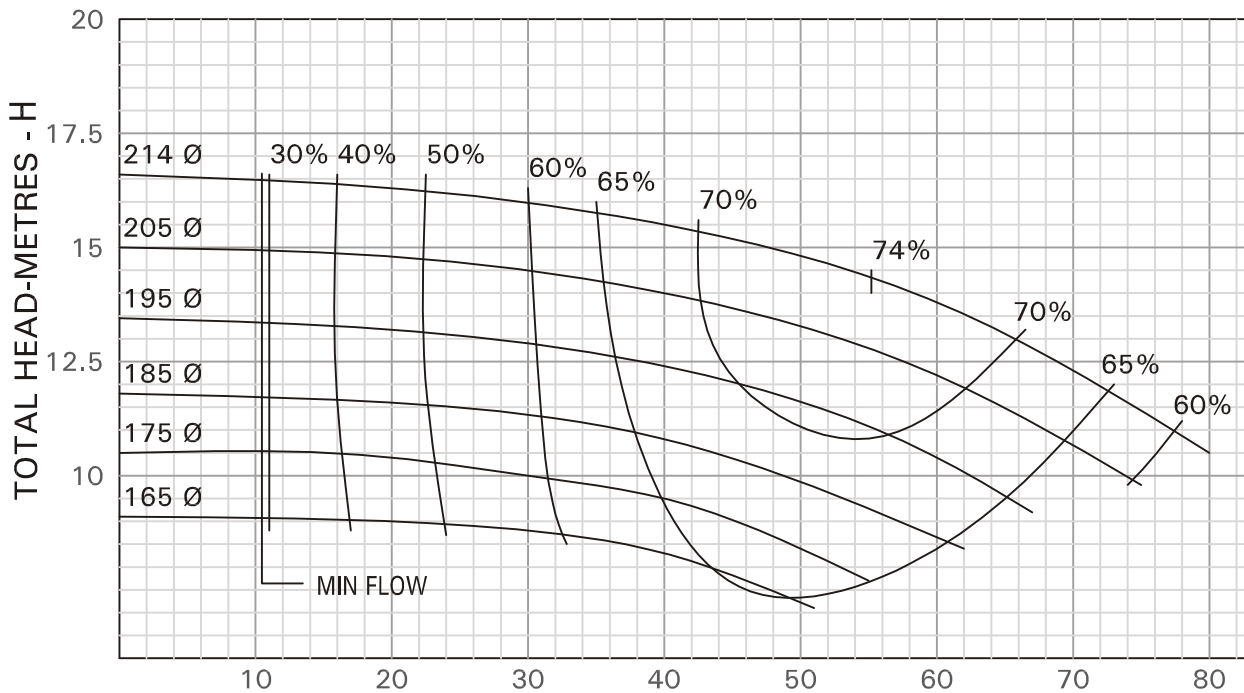

RECOMMENDED DELIVERY PIPE SIZE mm	80	100	125
RECOMMENDED SUCTION PIPE SIZE mm	100		125

**KIRLOSKAR BROTHERS LIMITED**

NO. HD10216B0

PERFORMANCE CURVE OF PUMP DB 65/26

SUC. 80 mm DEL 65mm

THIS CURVE RELATES TO LIQUID OF SP.GR. = 1.0

n = 1450 rpm  
(NOMINAL)



Enriching Lives

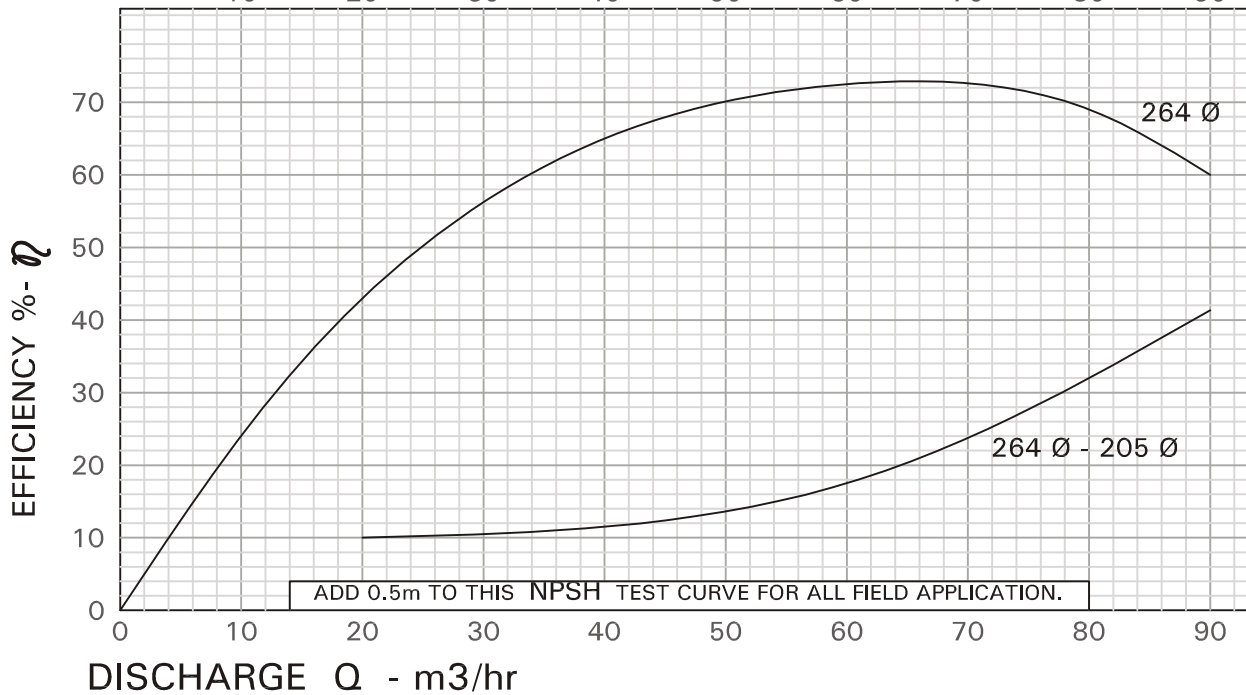
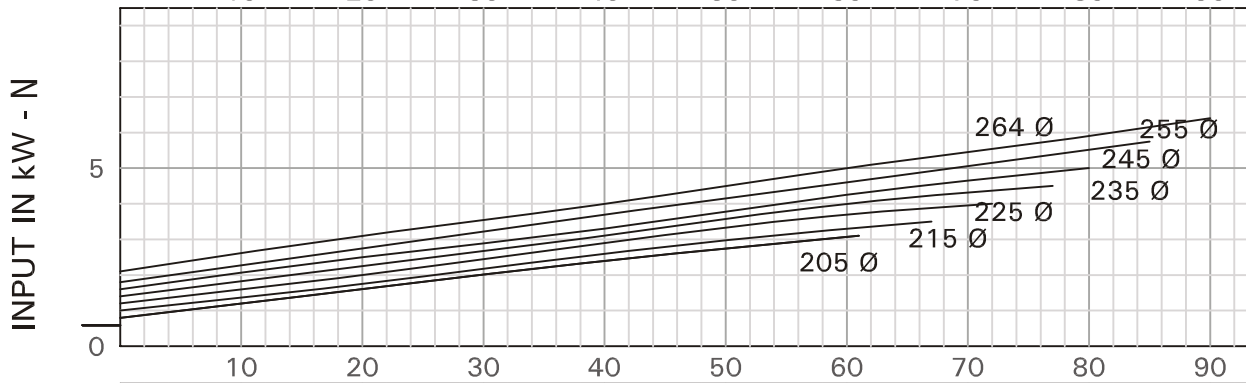
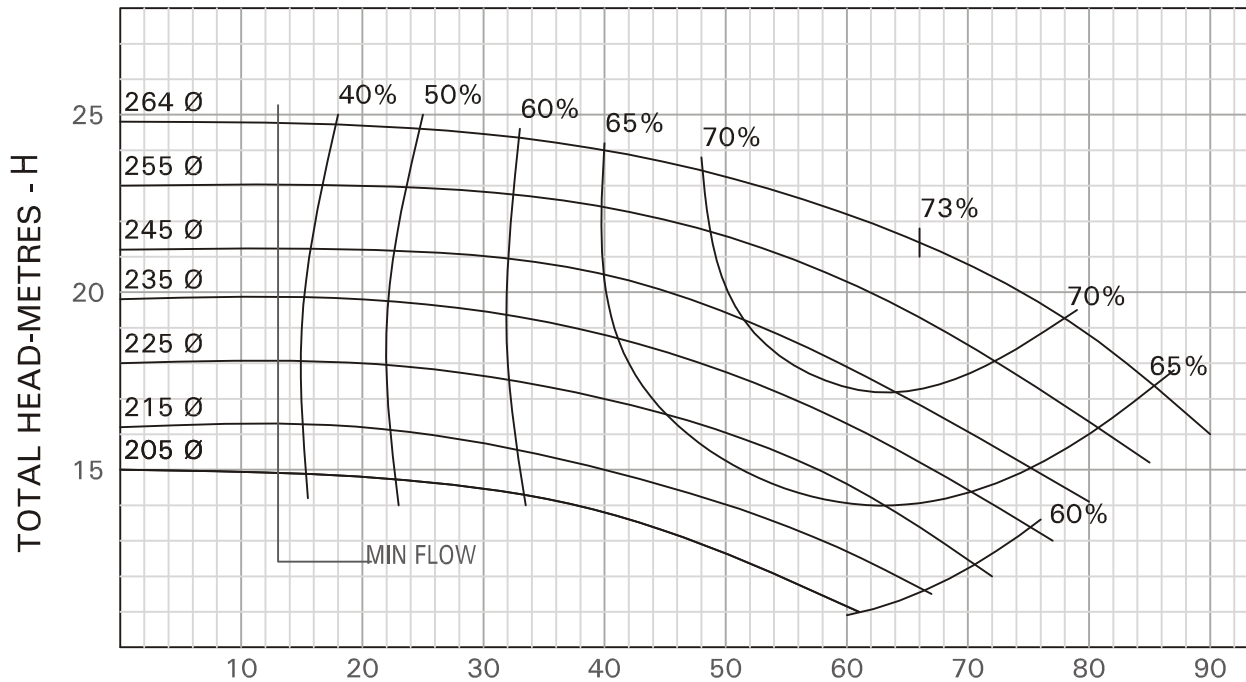

RECOMMENDED DELIVERY PIPE SIZE mm	80	100	125	
RECOMMENDED SUCTION PIPE SIZE mm	100	125	150	

# KIRLOSKAR BROTHERS LIMITED

NO. HD10217B0-R

## PERFORMANCE CURVE OF PUMP DB 65/32

SUC. 80 mm DEL 65 mm

THIS CURVE RELATES TO LIQUID OF SP.GR. = 1.0

n = 1450 rpm  
(NOMINAL)



Enriching Lives

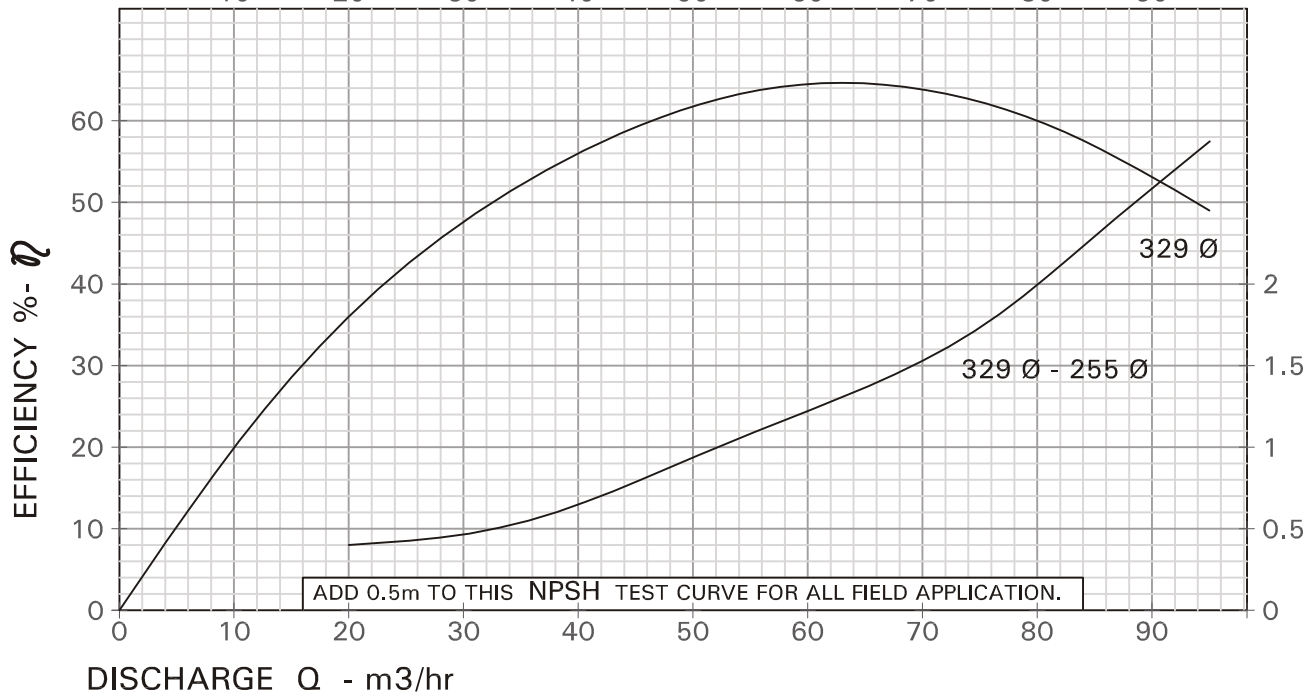
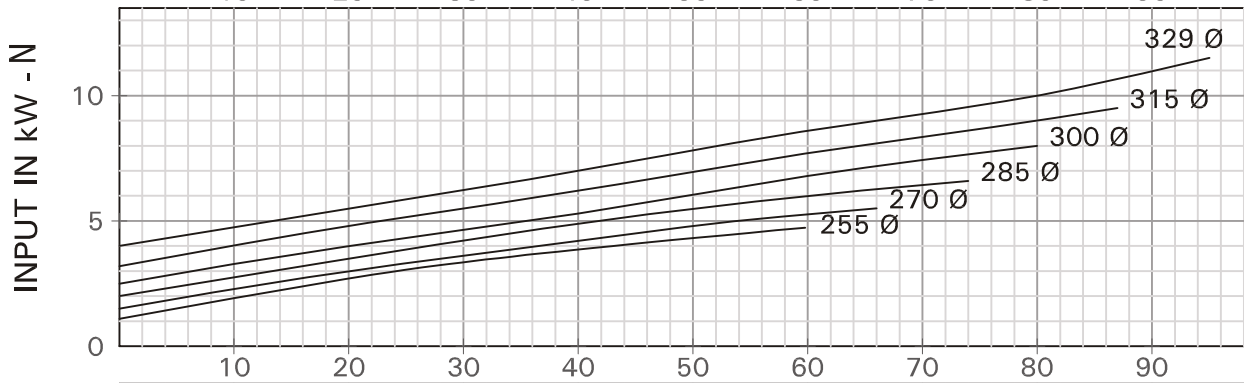
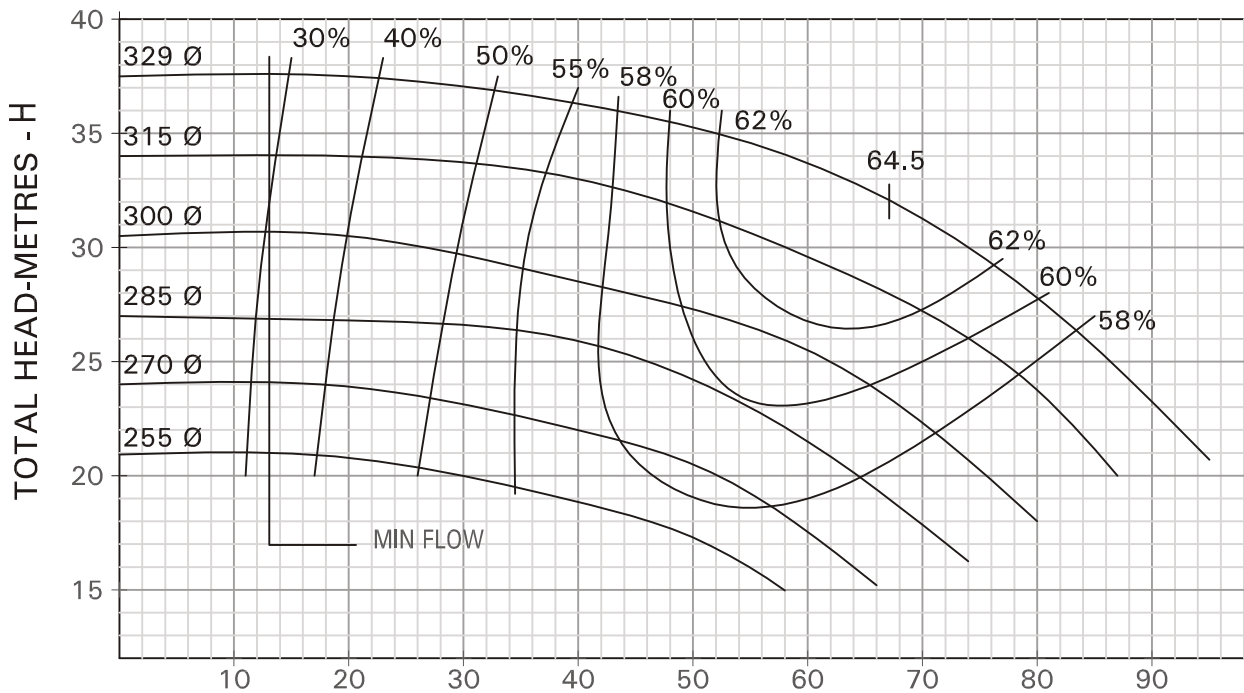

RECOMMENDED DELIVERY PIPE SIZE mm	100	125	
RECOMMENDED SUCTION PIPE SIZE mm	100	125	150

# KIRLOSKAR BROTHERS LIMITED

NO. HD10218B0

## PERFORMANCE CURVE OF PUMP DB 80/16

SUC. 100 mm DEL 80 mm

THIS CURVE RELATES TO LIQUID OF SP.GR. = 1.0

n = 1450 rpm  
(NOMINAL)



Enriching Lives

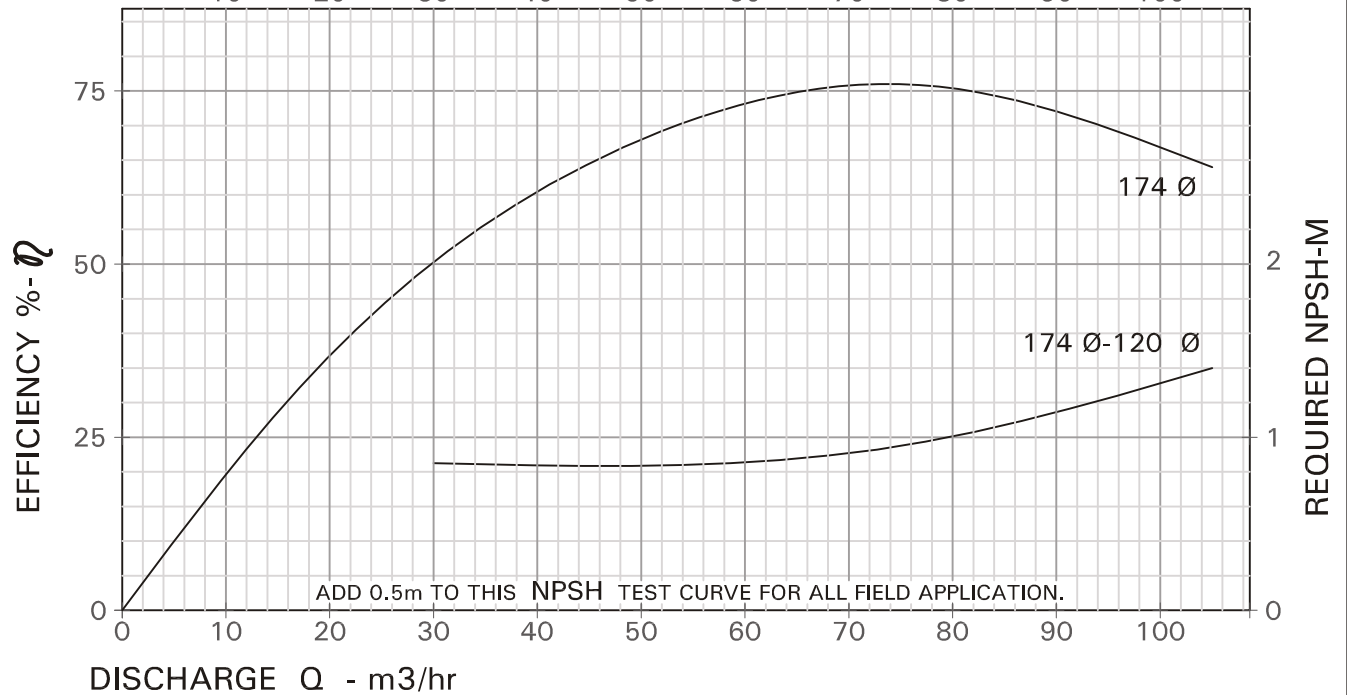
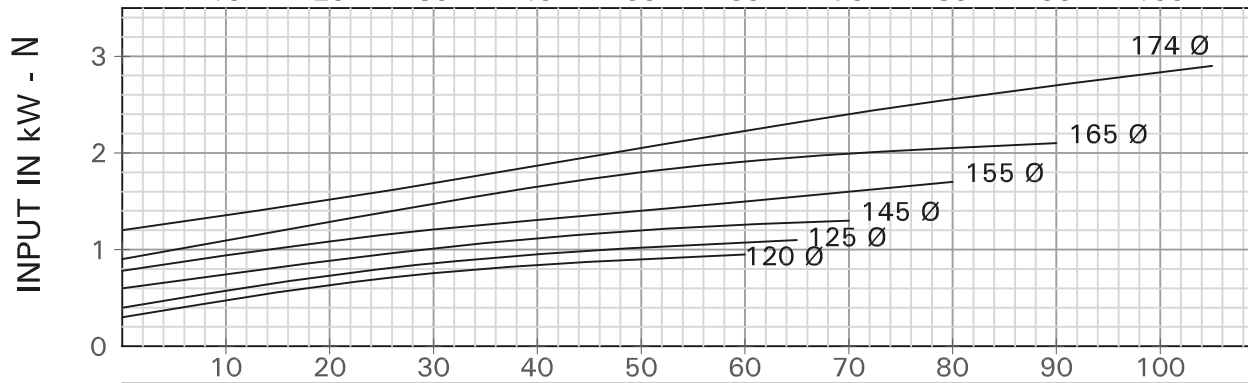
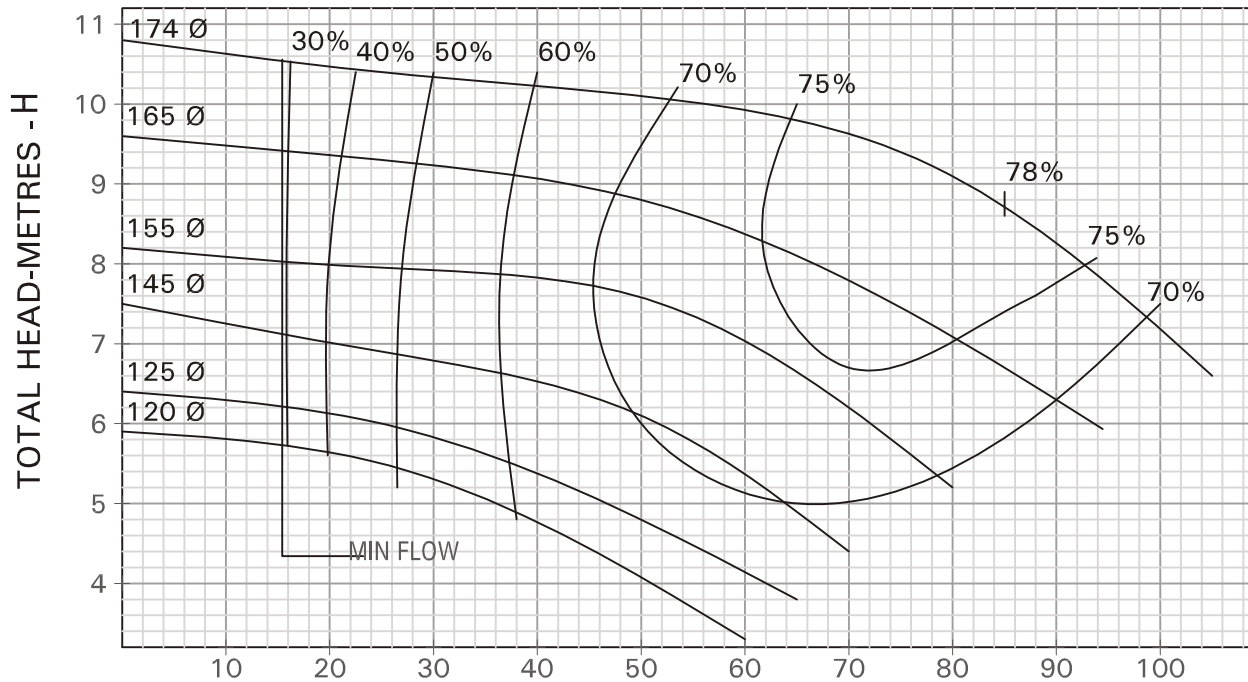

RECOMMENDED DELIVERY PIPE SIZE mm	100	125	
RECOMMENDED SUCTION PIPE SIZE mm	125	150	

# KIRLOSKAR BROTHERS LIMITED

NO. HD10219B0

## PERFORMANCE CURVE OF PUMP DB 80/20

SUC. 100 mm DEL 80 mm

THIS CURVE RELATES TO LIQUID OF SP.GR. = 1.0

n = 1450 rpm  
(NOMINAL)



Enriching Lives

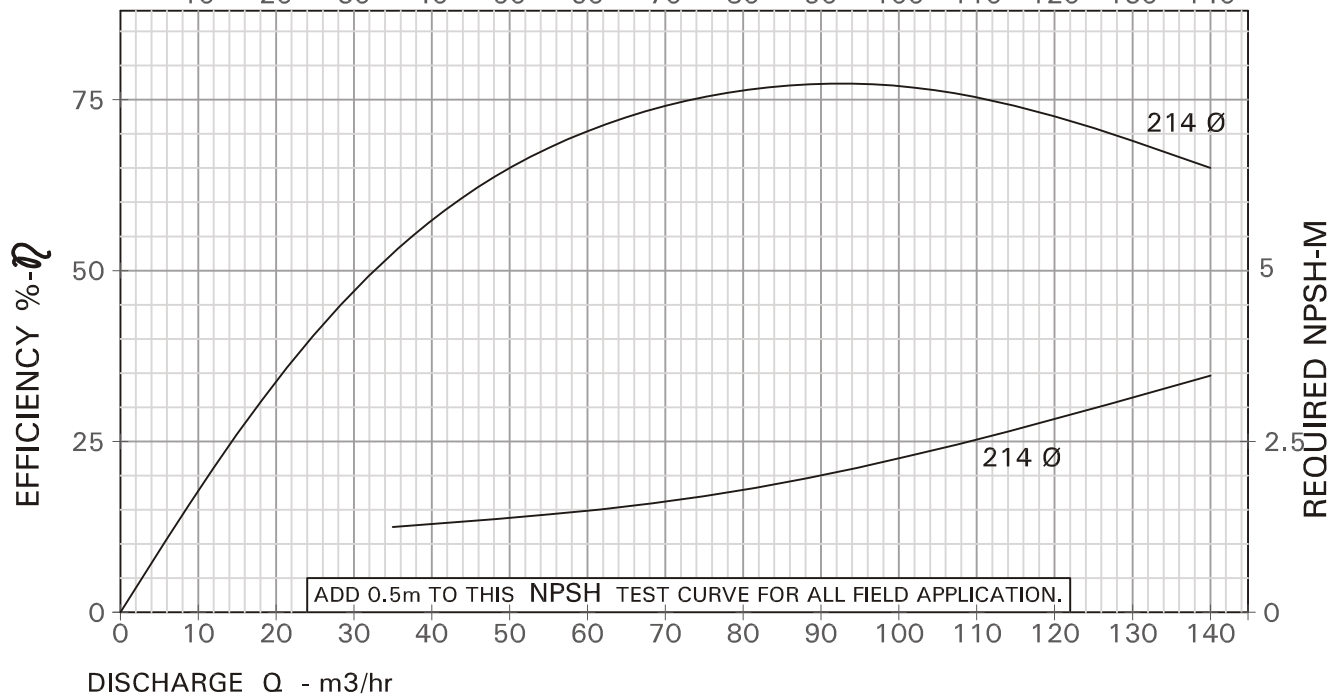
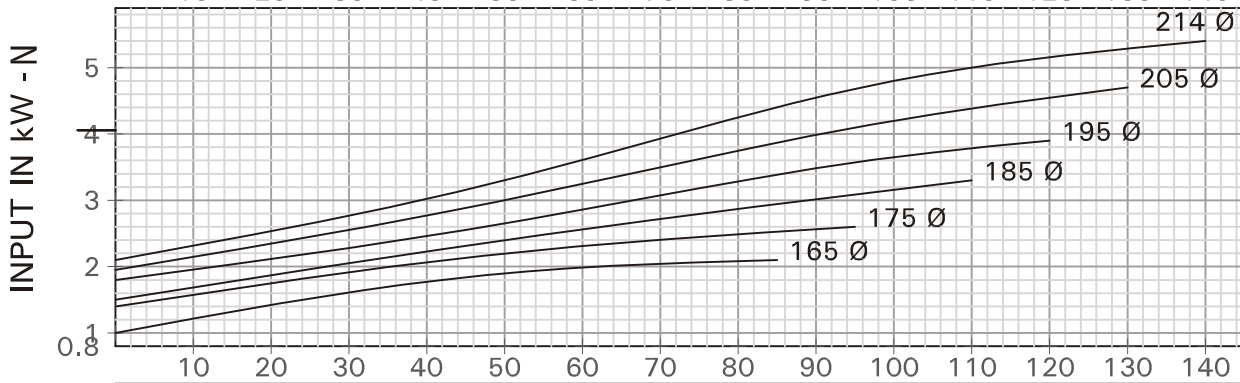
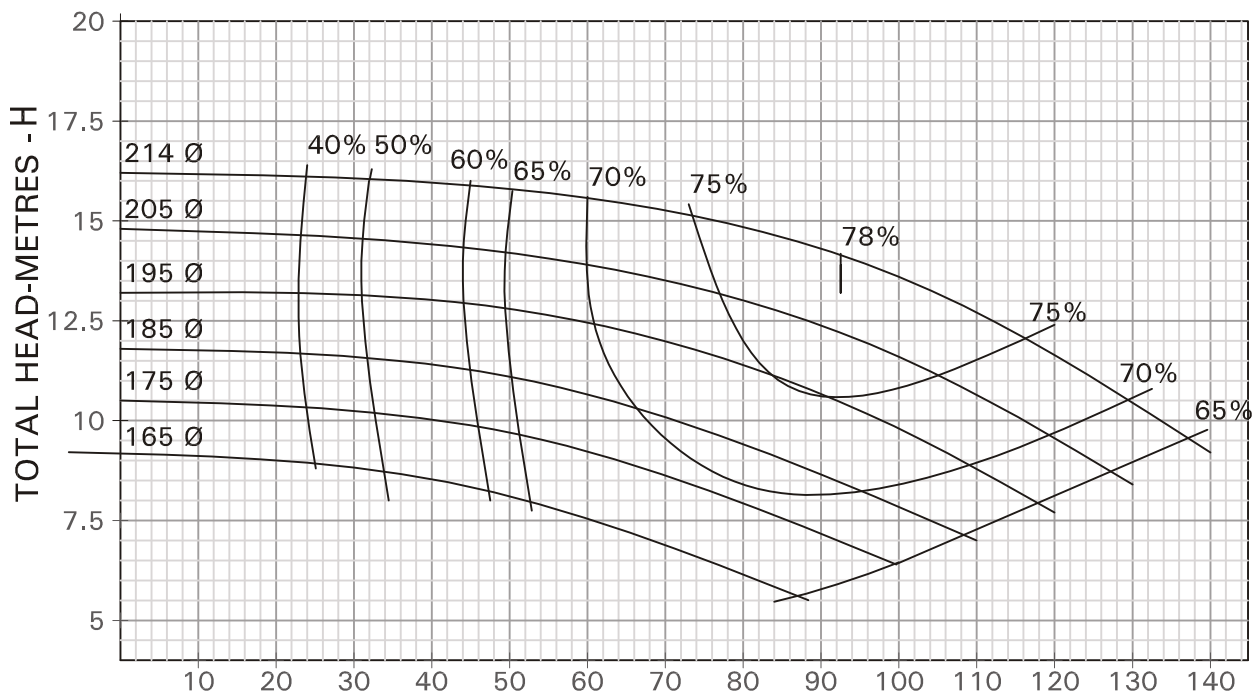

RECOMMENDED DELIVERY PIPE SIZE mm	
RECOMMENDED SUCTION PIPE SIZE mm	

# KIRLOSKAR BROTHERS LIMITED

NO. HD10220B0

## PERFORMANCE CURVE OF PUMP DB 80/26

SUC. 100 mm DEL. 80 mm

THIS CURVE RELATES TO LIQUID OF SP.GR. = 1.0

n = 1450<sup>rpm</sup>  
(NOMINAL)



Enriching Lives

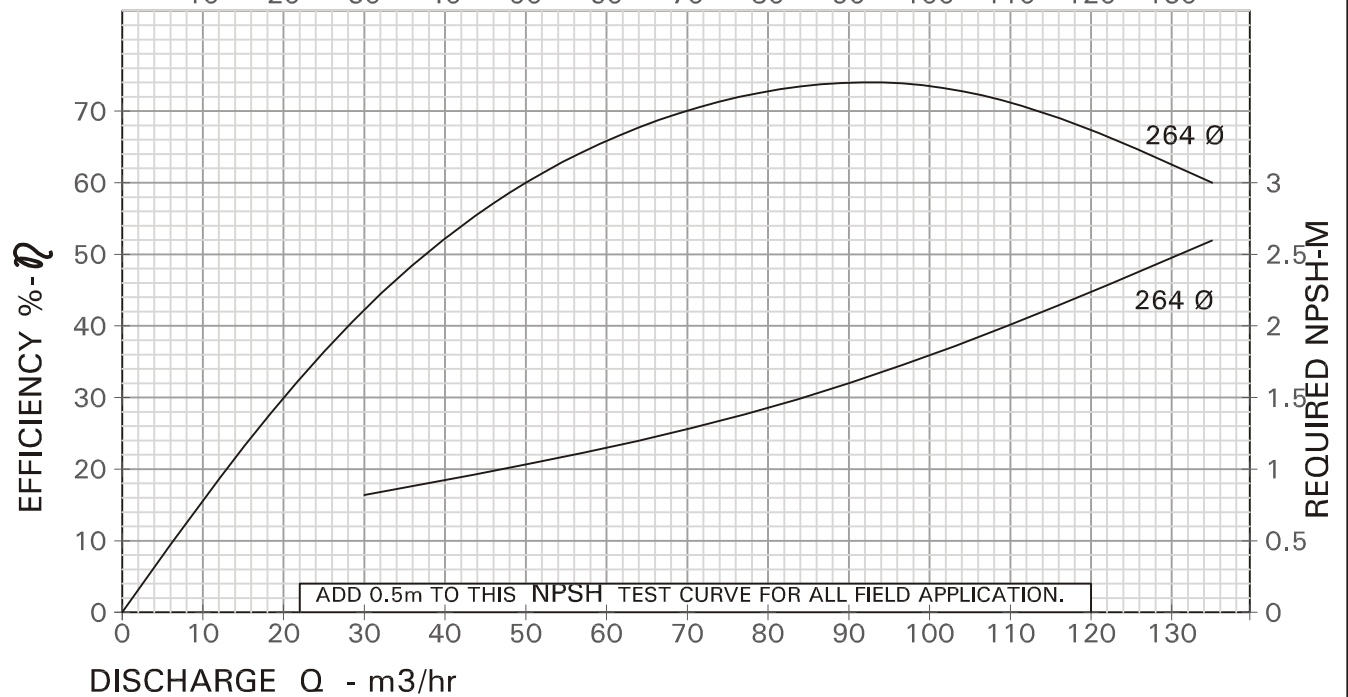
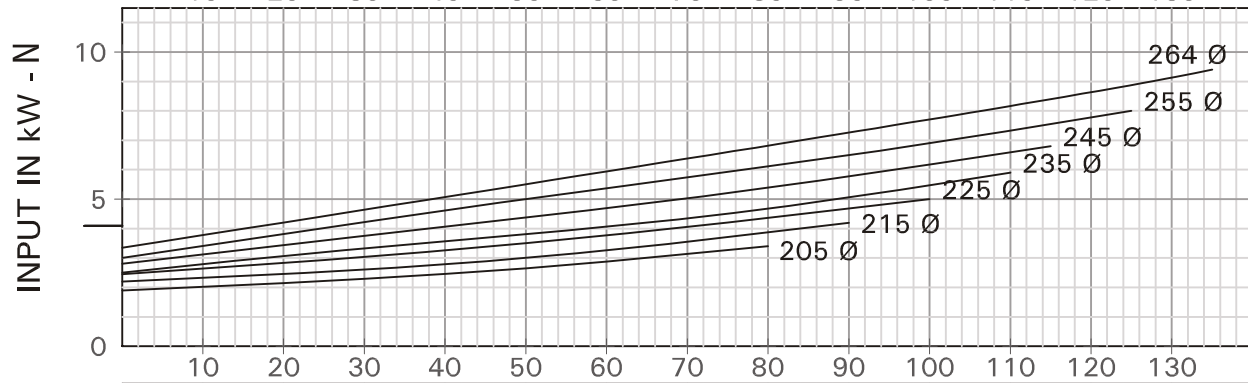
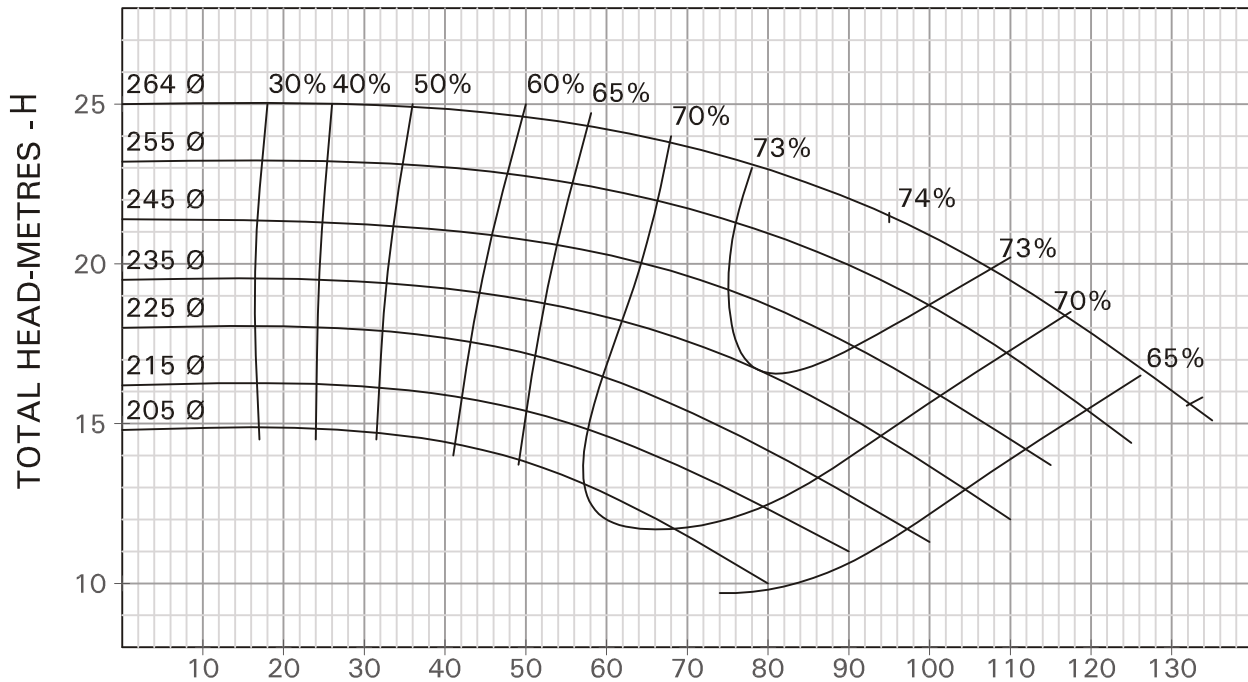

RECOMMENDED DELIVERY PIPE SIZE mm	
RECOMMENDED SUCTION PIPE SIZE mm	

# KIRLOSKAR BROTHERS LIMITED

NO. HD10221B0

## PERFORMANCE CURVE OF PUMP DB 80/32

SUC. 100 mm DEL 80 mm

THIS CURVE RELATES TO LIQUID OF SP.GR. = 1.0

n = 1450<sup>rpm</sup>  
(NOMINAL)



Enriching Lives

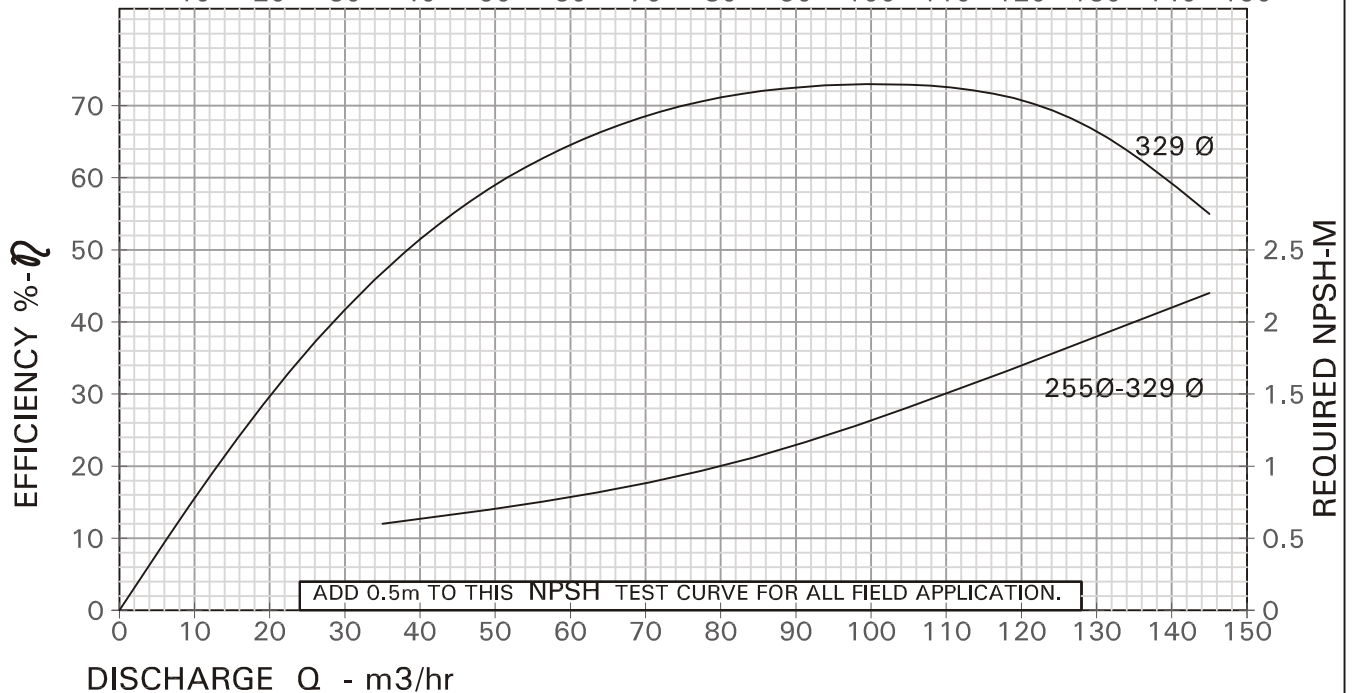
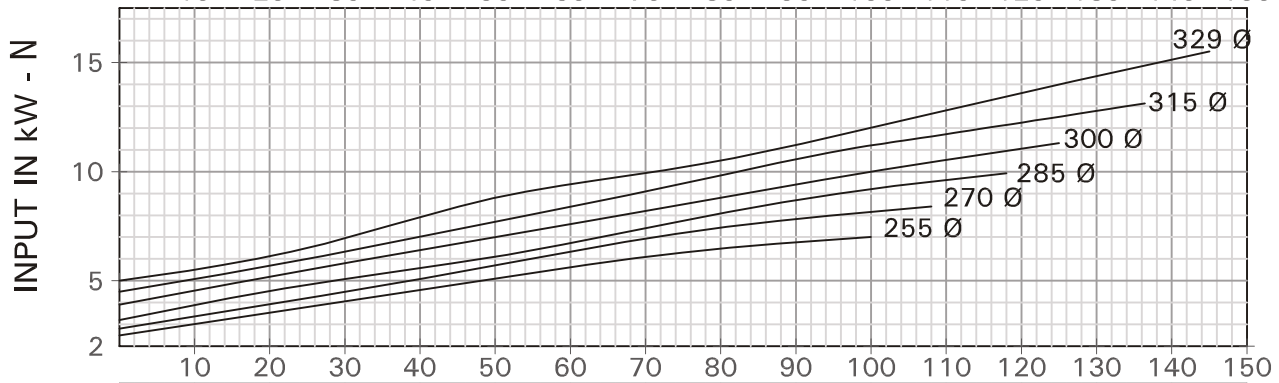
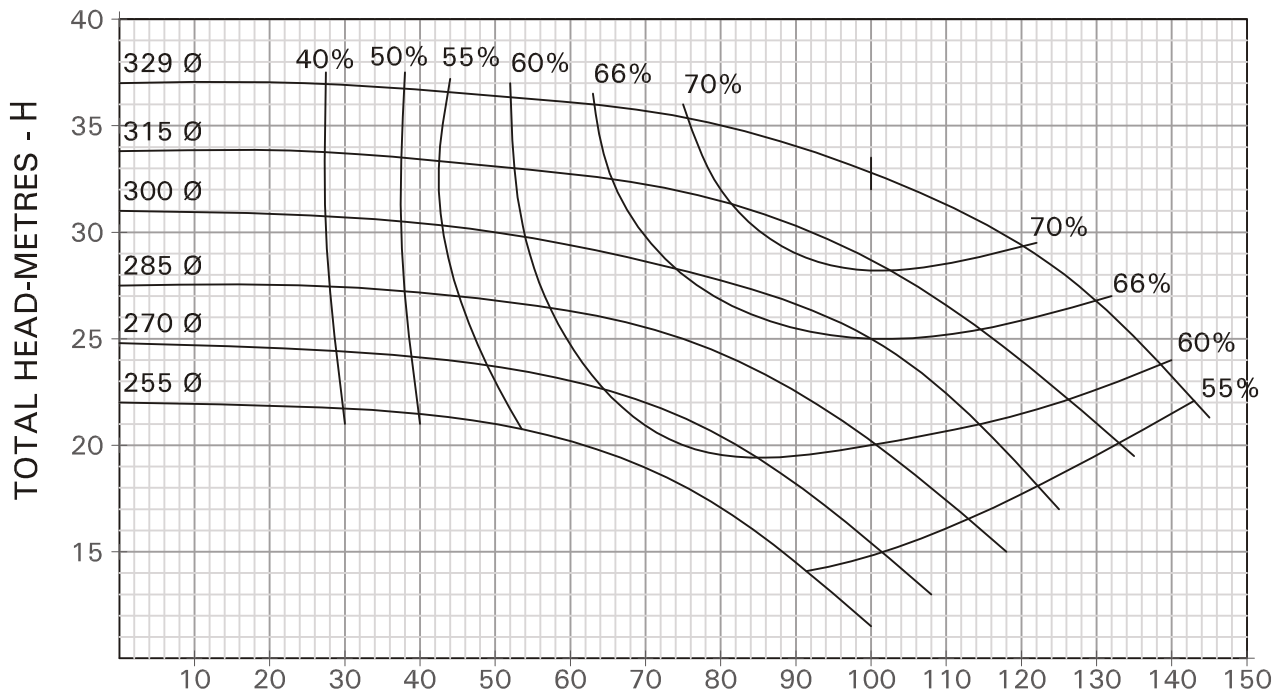

RECOMMENDED DELIVERY PIPE SIZE mm	100	125	150	
RECOMMENDED SUCTION PIPE SIZE mm	130	150	175	

# KIRLOSKAR BROTHERS LIMITED

NO. HD10222B0

## PERFORMANCE CURVE OF PUMP DB 100/20

SUC. 125 mm DEL 100 mm

THIS CURVE RELATES TO LIQUID OF SP.GR. = 1.0

n = 1450<sup>rpm</sup>  
(NOMINAL)



Enriching Lives

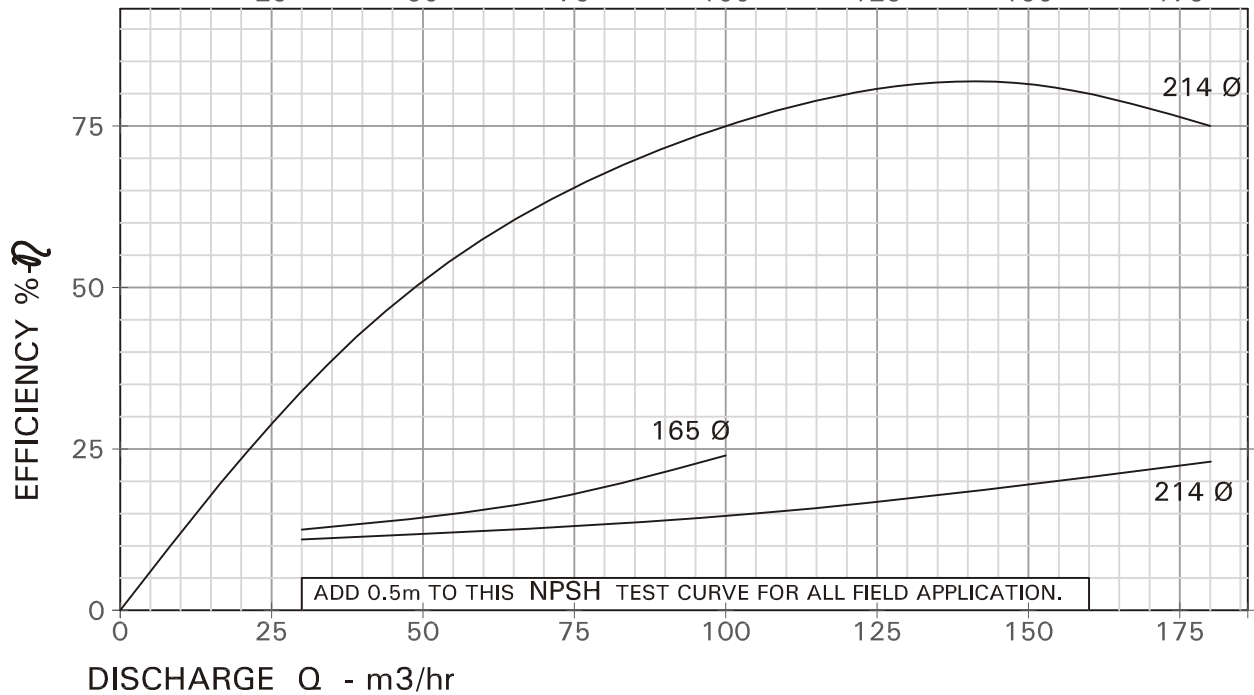
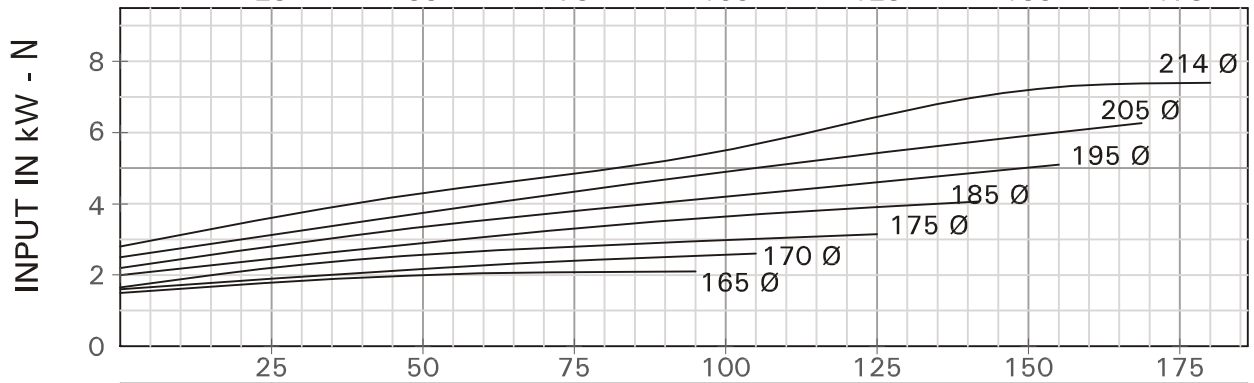
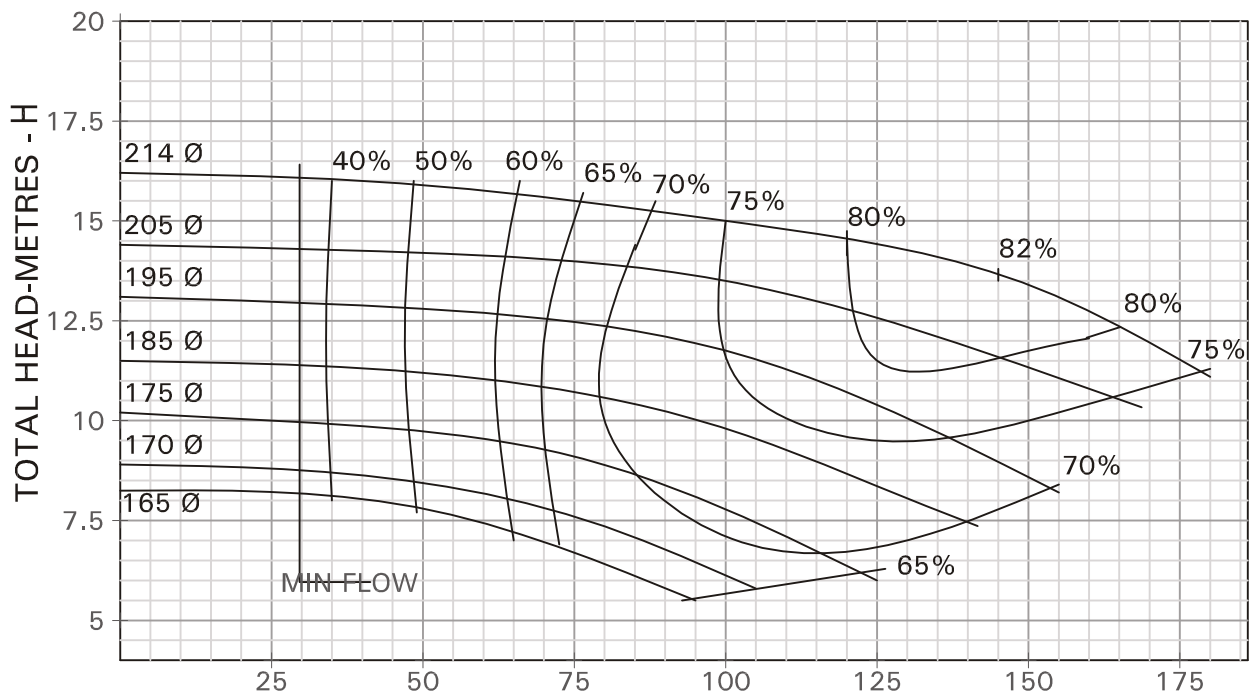

RECOMMENDED DELIVERY PIPE SIZE mm	100	125	150	175
RECOMMENDED SUCTION PIPE SIZE mm	125	150	175	

# KIRLOSKAR BROTHERS LIMITED

NO. HD10223B0

## PERFORMANCE CURVE OF PUMP DB 100/26

SUC. 125 mm DEL 100 mm

THIS CURVE RELATES TO LIQUID OF SP.GR. = 1.0

n = 1450<sup>rpm</sup>  
(NOMINAL)



Enriching Lives

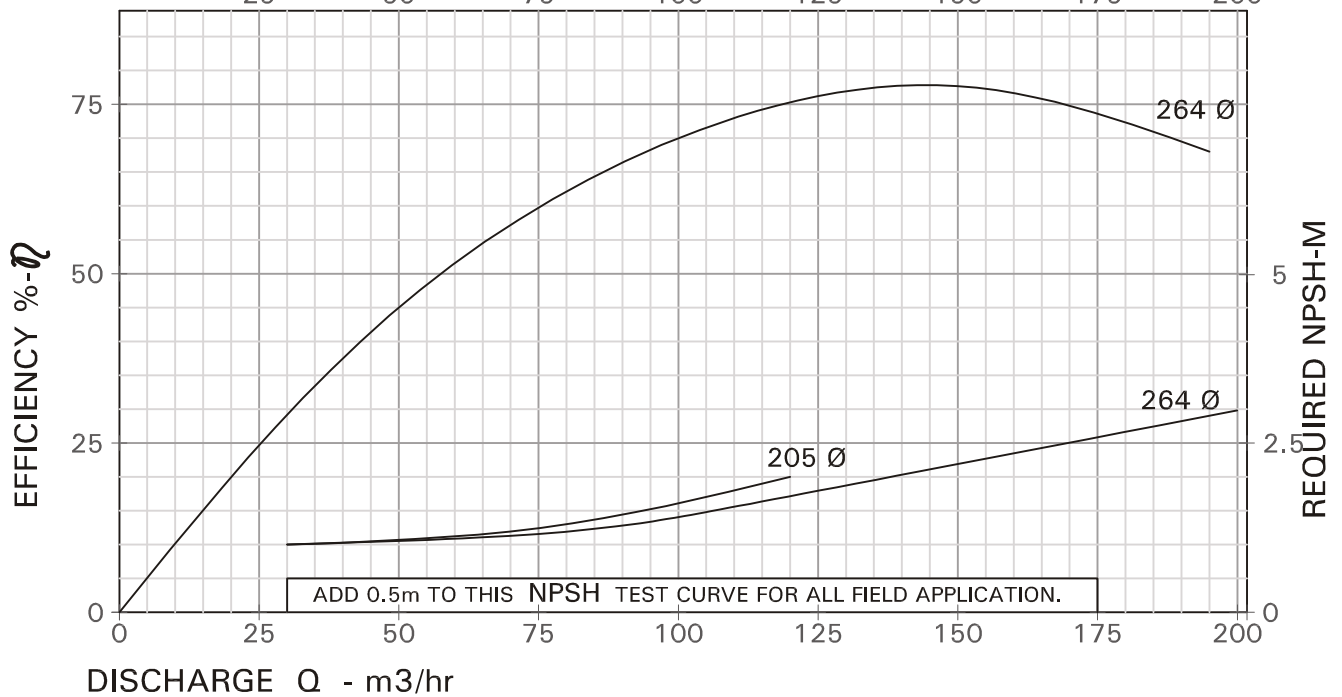
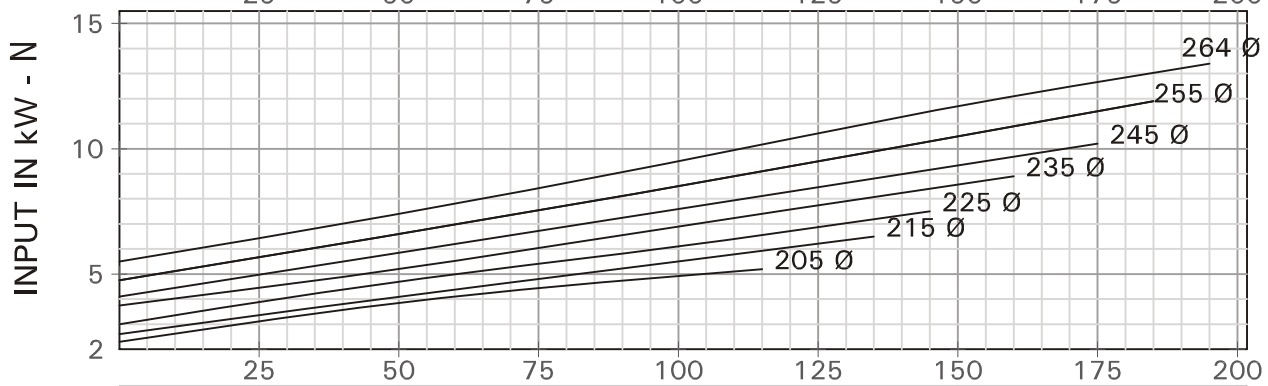
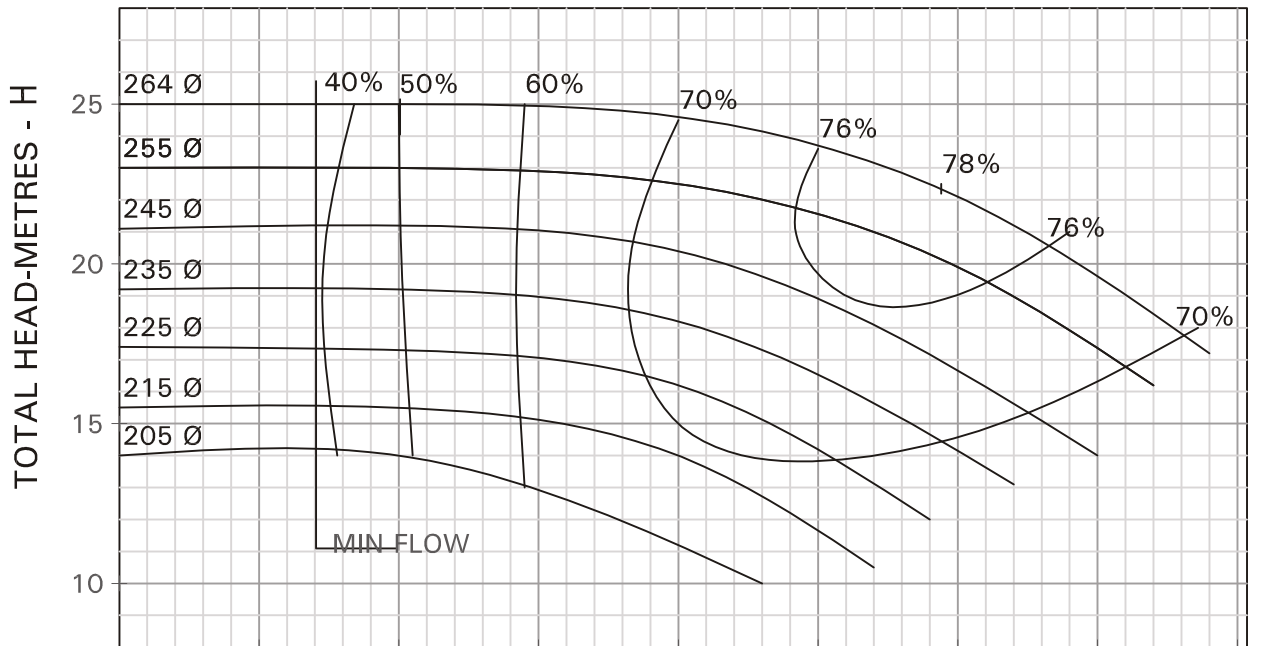

RECOMMENDED DELIVERY PIPE SIZE mm	100	125	150	175	
RECOMMENDED SUCTION PIPE SIZE mm	125	150	175	200	

# KIRLOSKAR BROTHERS LIMITED

NO. HD10224B0

## PERFORMANCE CURVE OF PUMP DB 100/32

SUC. 125 mm DEL 100 mm

THIS CURVE RELATES TO LIQUID OF SP.GR. = 1.0

$n = 1450^{rpm}$   
(NOMINAL)



Enriching Lives

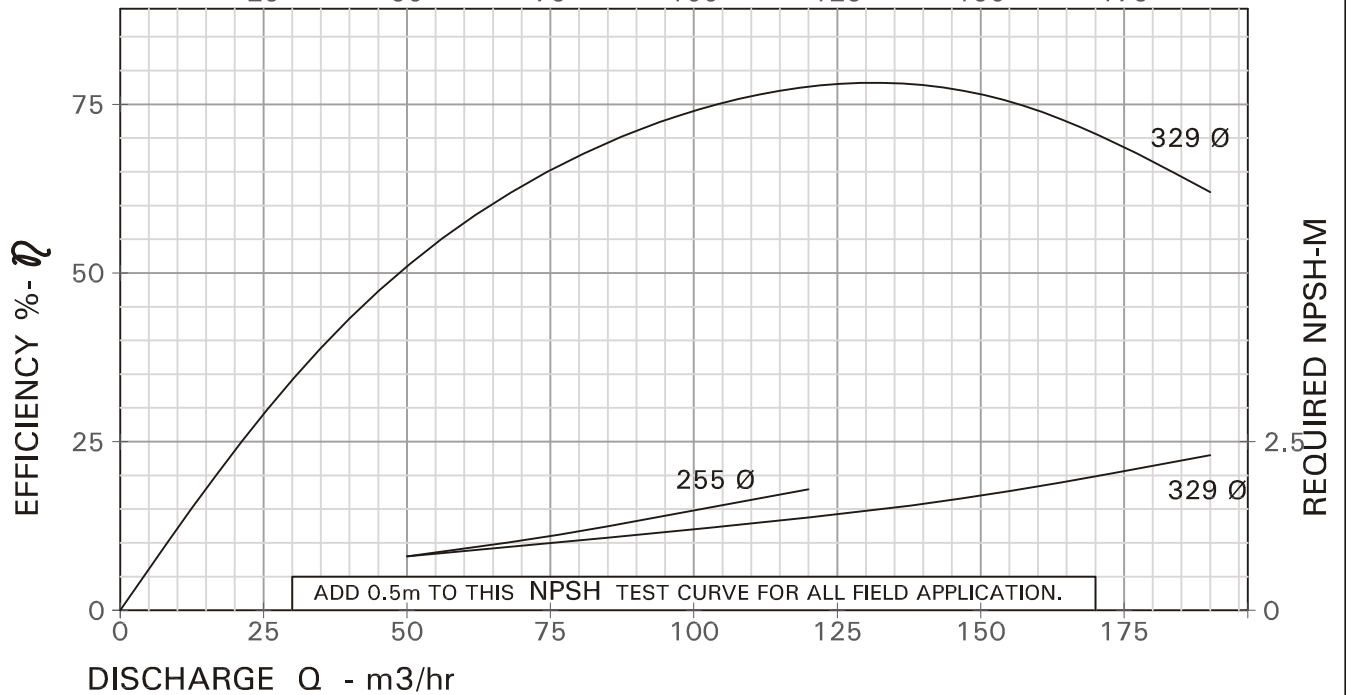
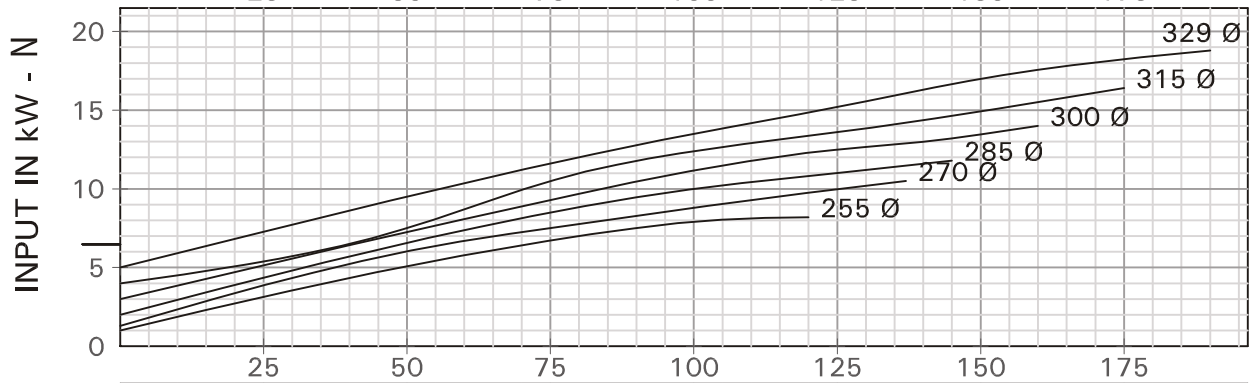
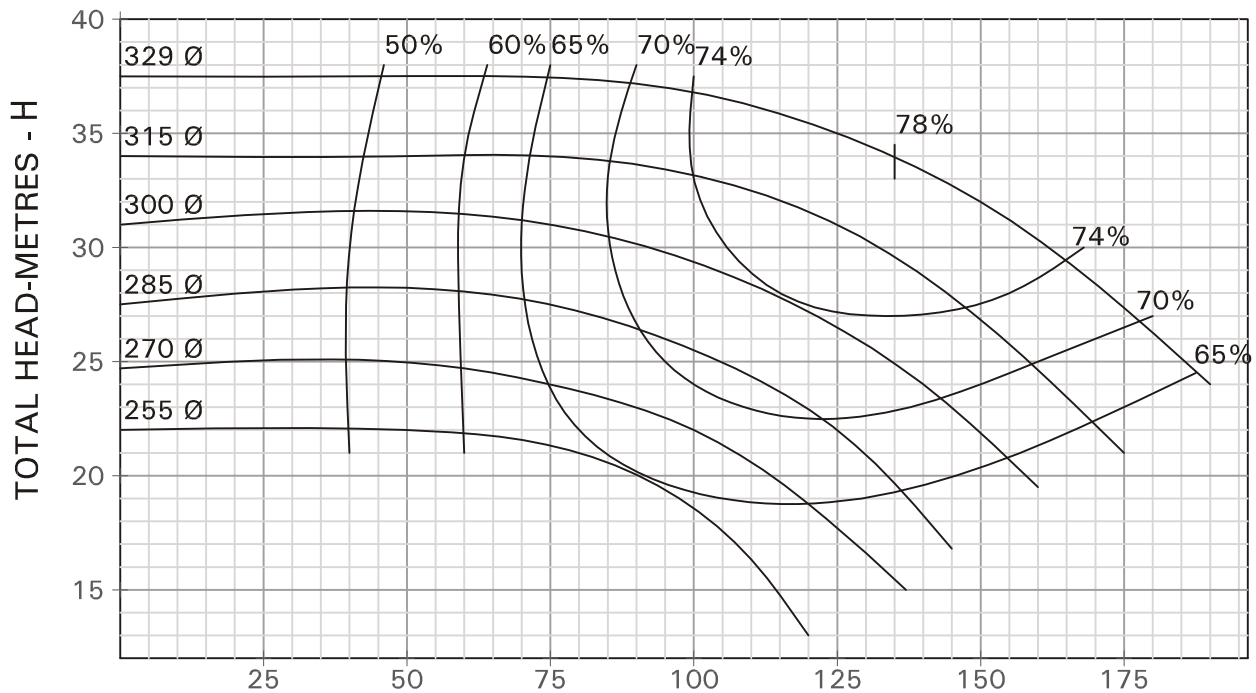

RECOMMENDED DELIVERY PIPE SIZE mm	125	150	175	
RECOMMENDED SUCTION PIPE SIZE mm	150	175	200	

# KIRLOSKAR BROTHERS LIMITED

NO. HD10225B0

## PERFORMANCE CURVE OF PUMP DB 100/40

SUC. 125 mm DEL 100 mm

THIS CURVE RELATES TO LIQUID OF SP.GR. = 1.0

n = 1450 rpm  
(NOMINAL)



Enriching Lives

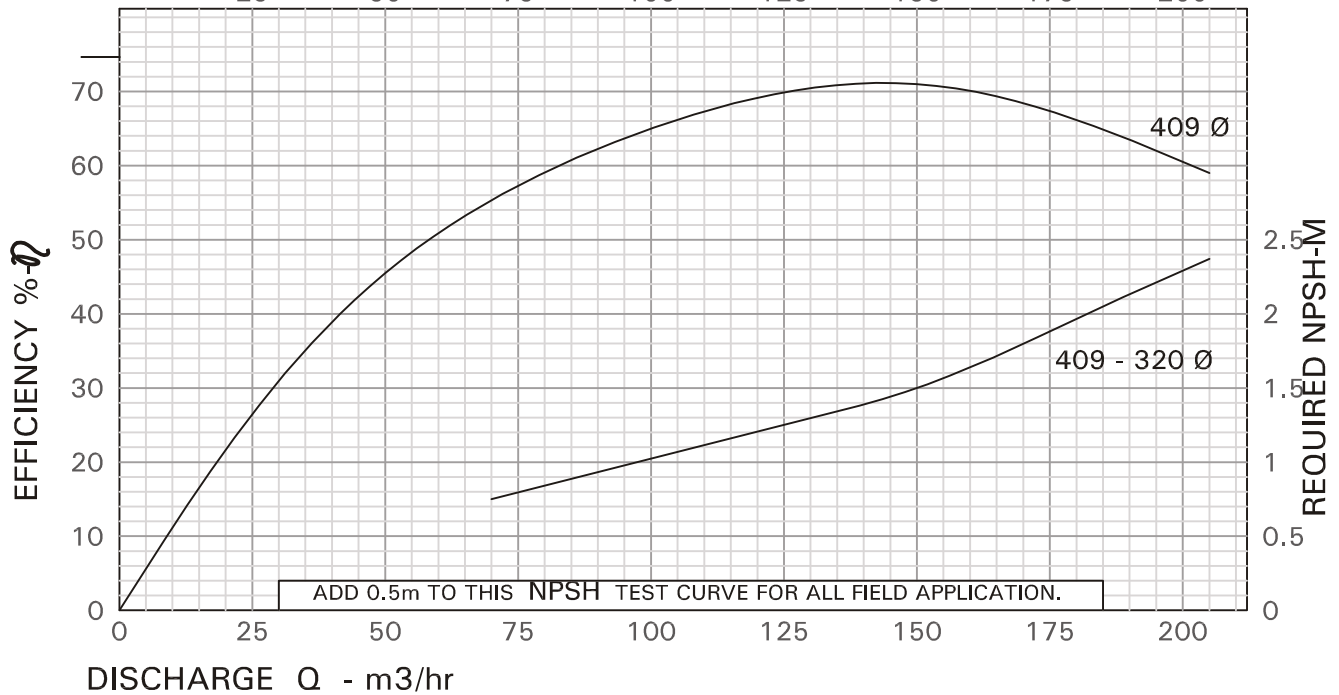
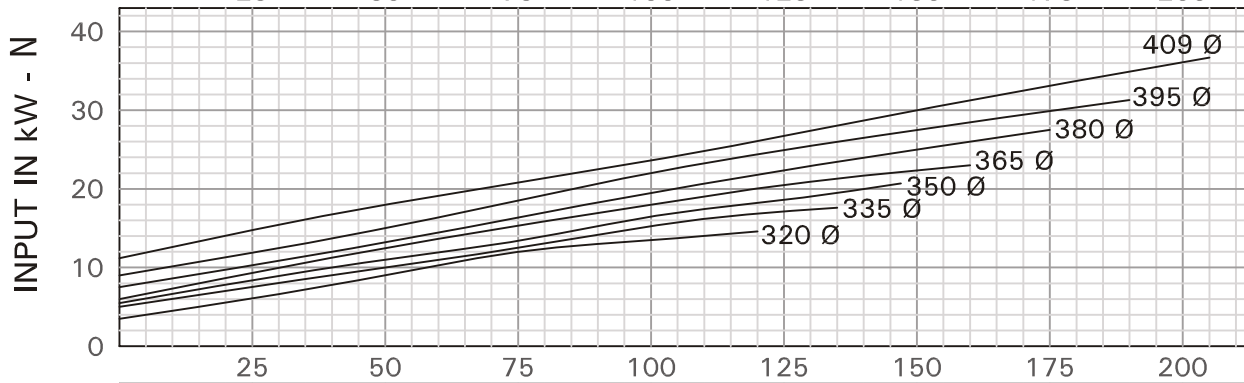
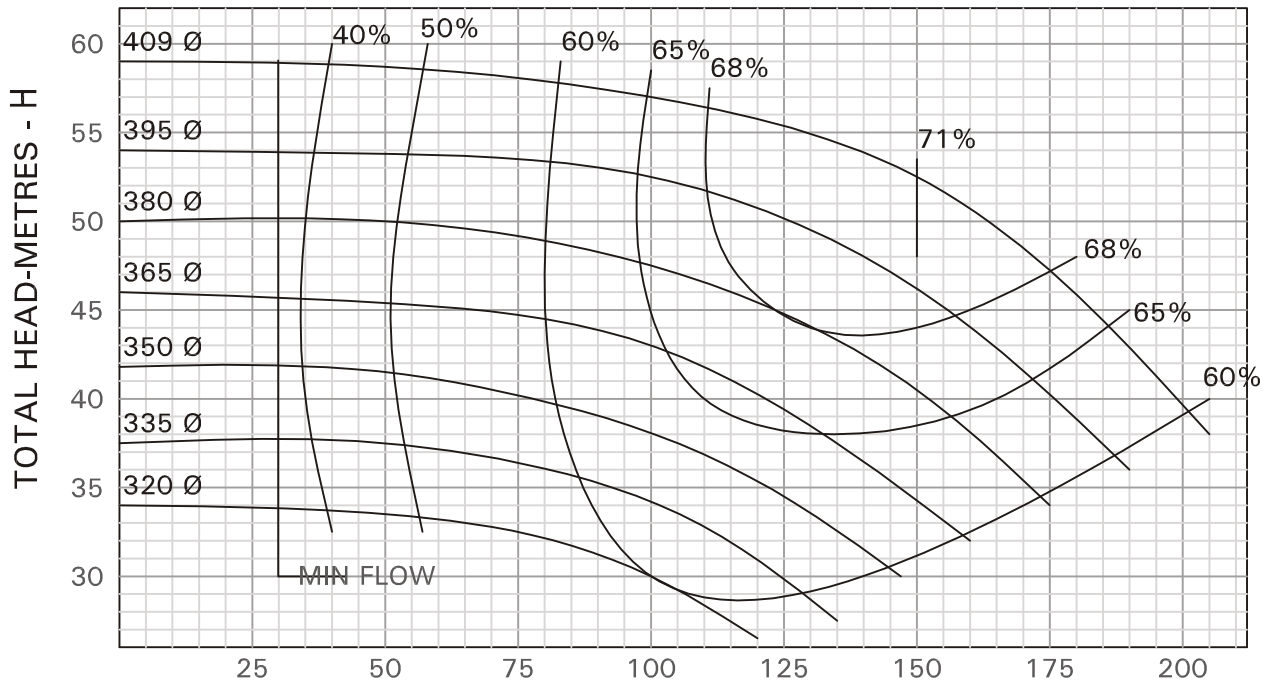

RECOMMENDED DELIVERY PIPE SIZE mm	100	125	150	175	
RECOMMENDED SUCTION PIPE SIZE mm	125	150	175	200	

# KIRLOSKAR BROTHERS LIMITED

NO. HD10226B0

## PERFORMANCE CURVE OF PUMP DB 125/26

SUC. 150 mm DEL 125mm

THIS CURVE RELATES TO LIQUID OF SP.GR. = 1.0

n = 1450 rpm  
(NOMINAL)



Enriching Lives

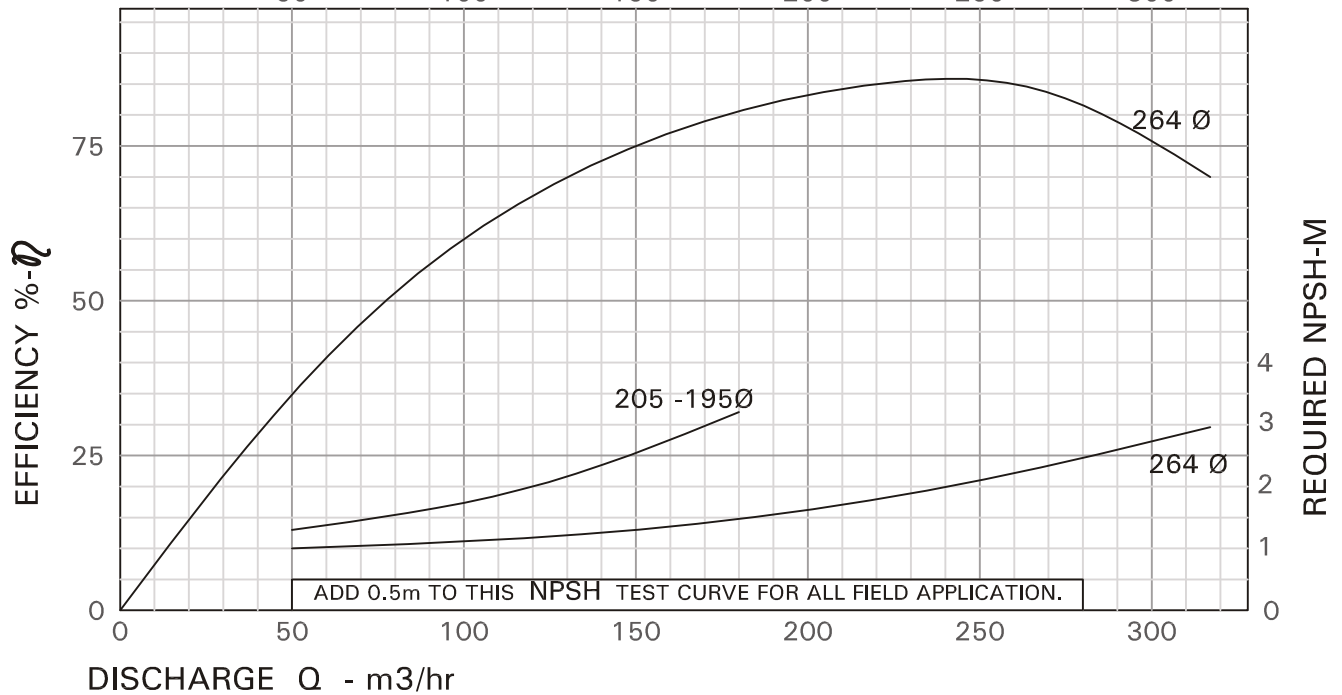
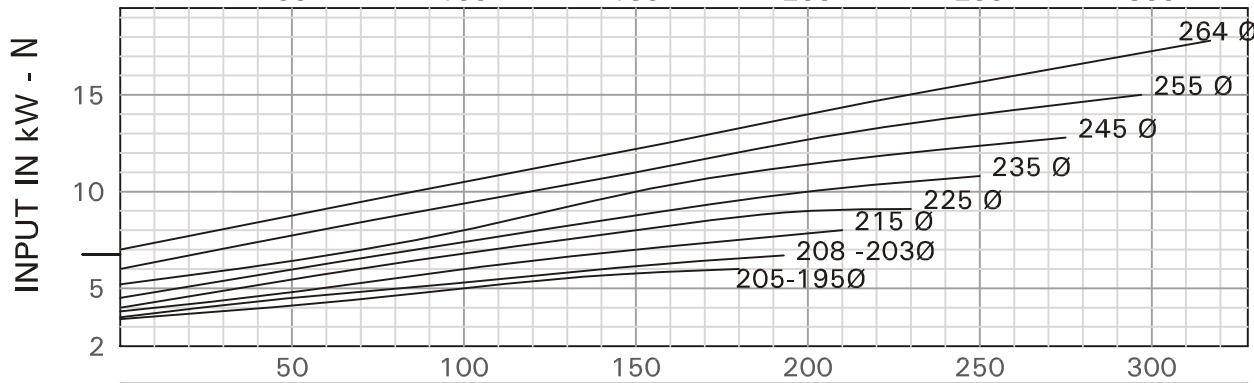
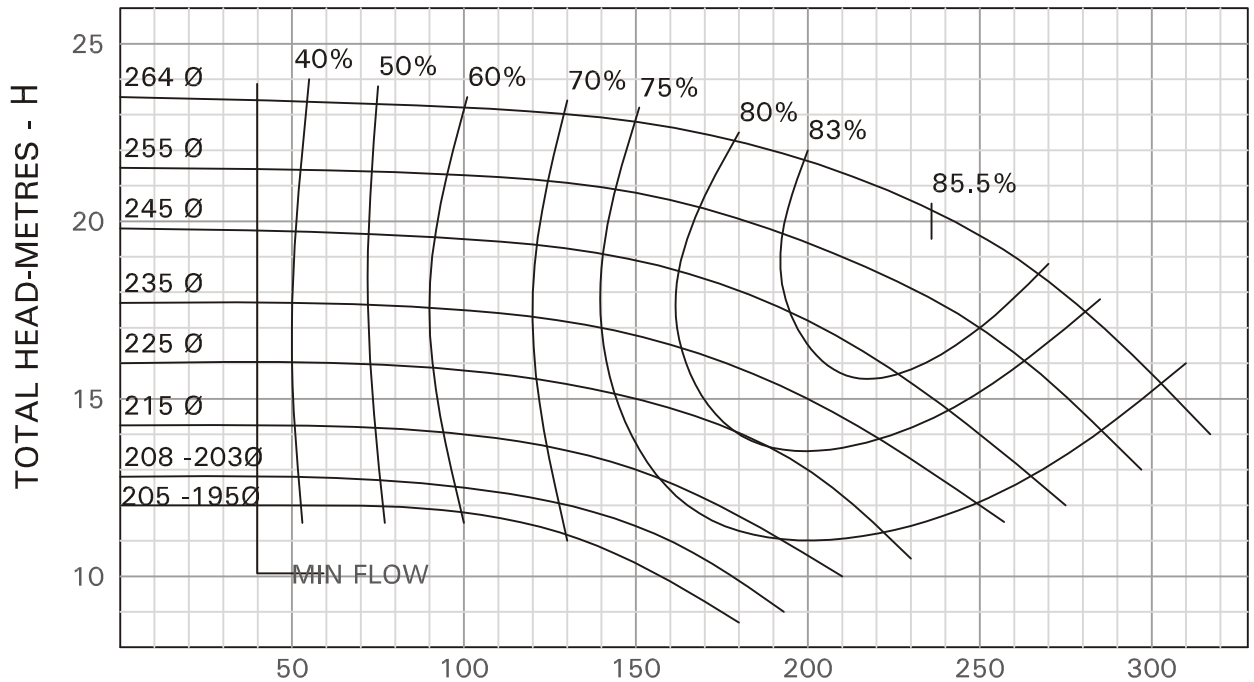

RECOMMENDED DELIVERY PIPE SIZE mm	150	175	200	225
RECOMMENDED SUCTION PIPE SIZE mm	175	200	225	250

**KIRLOSKAR BROTHERS LIMITED**

NO. HD10227B0

PERFORMANCE CURVE OF PUMP DB 125/32

SUC. 150 mm DEL. 125 mm

THIS CURVE RELATES TO LIQUID OF SP.GR. = 1.0

n = 1450<sup>rpm</sup>  
(NOMINAL)



Enriching Lives

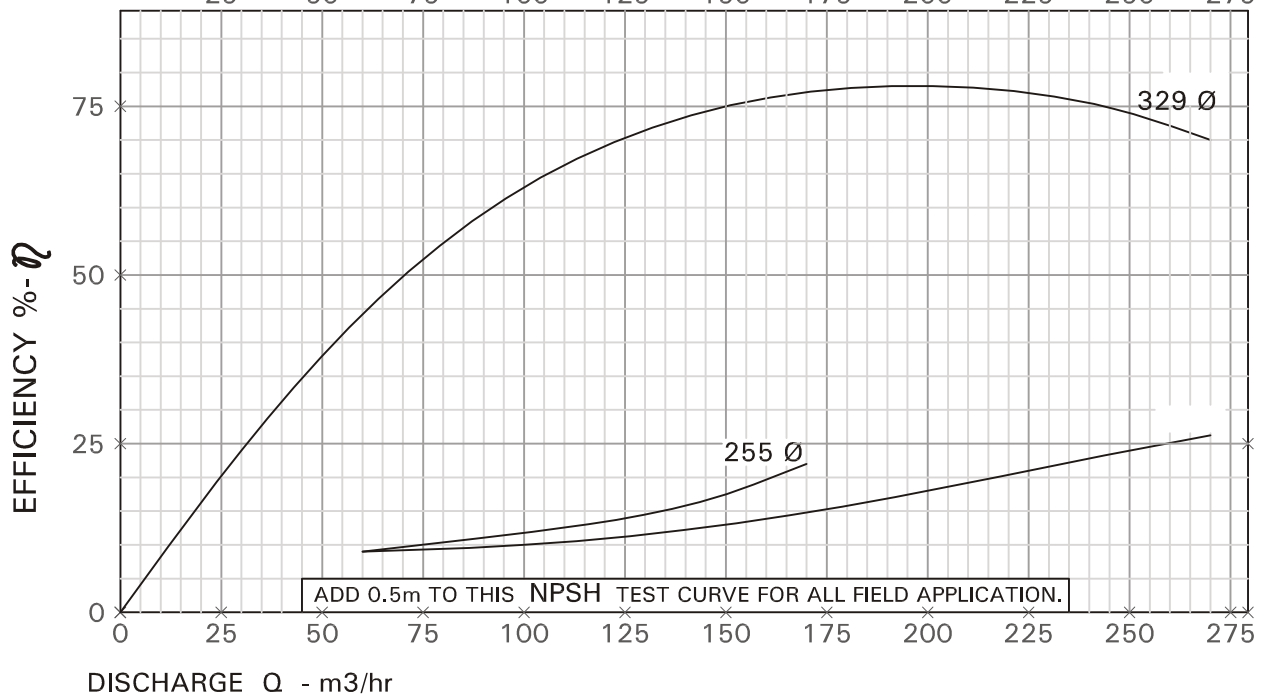
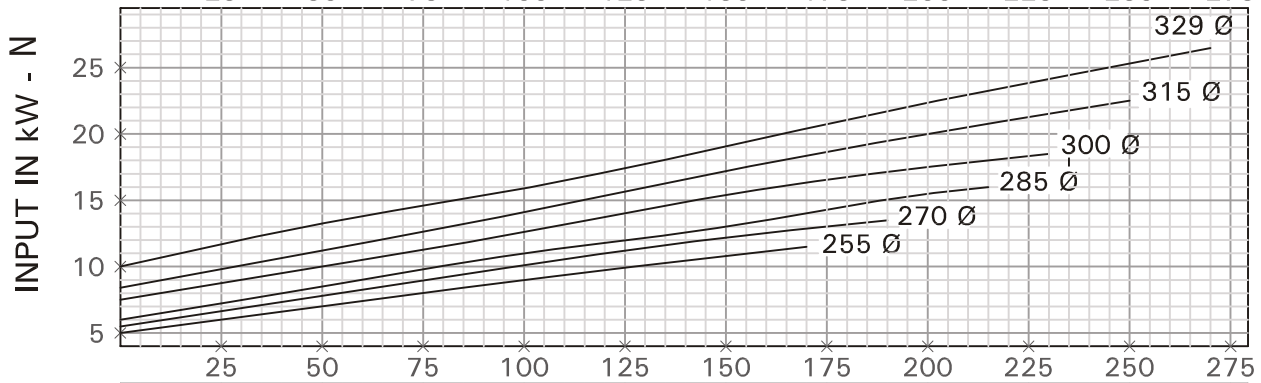
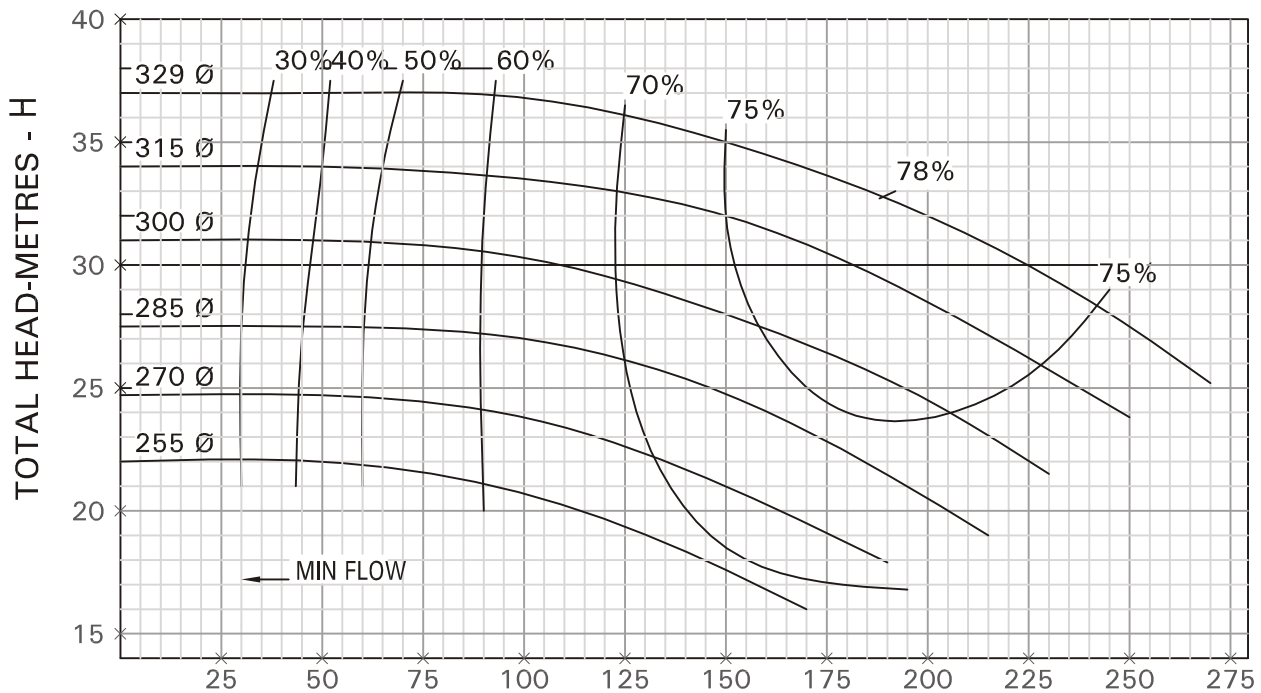

RECOMMENDED DELIVERY PIPE SIZE mm	125	150	175	200	
RECOMMENDED SUCTION PIPE SIZE mm	125	150	175	200	225 250

# KIRLOSKAR BROTHERS LIMITED

NO. HD10228B0

## PERFORMANCE CURVE OF PUMP DB 125/40

SUC. 150 mm DEL. 125 mm

THIS CURVE RELATES TO LIQUID OF SP.GR. = 1.0

n = 1450 rpm  
(NOMINAL)



Enriching Lives

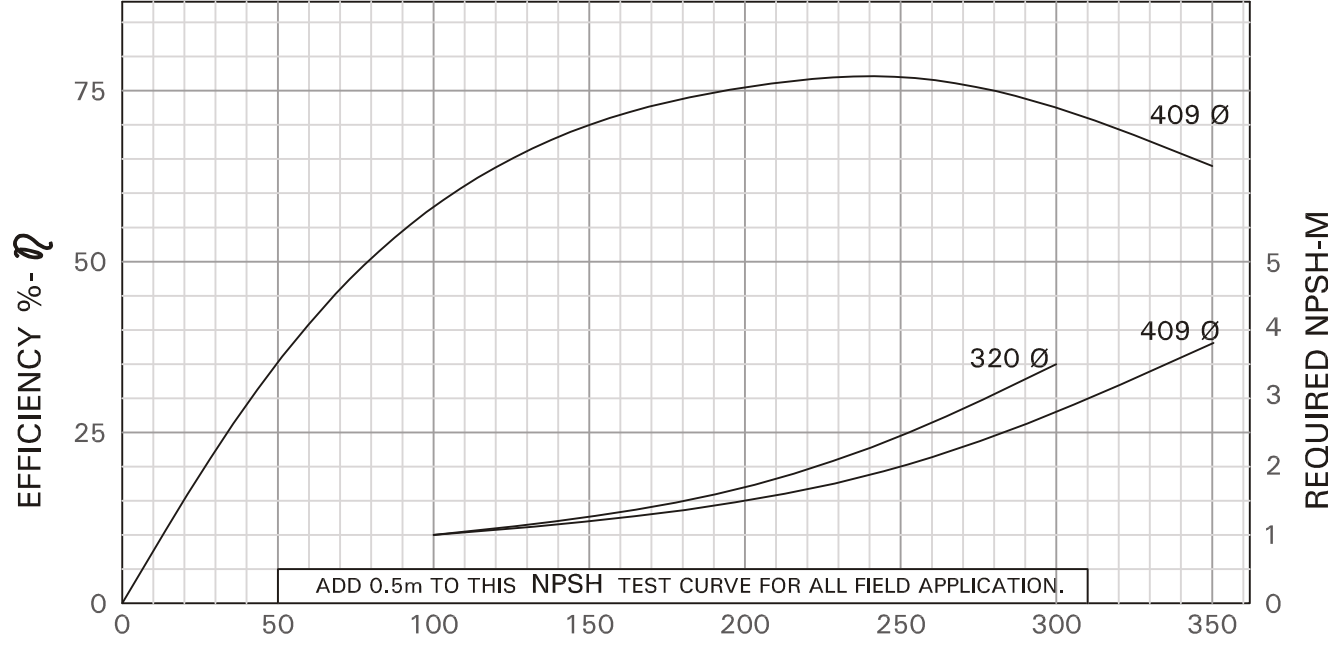
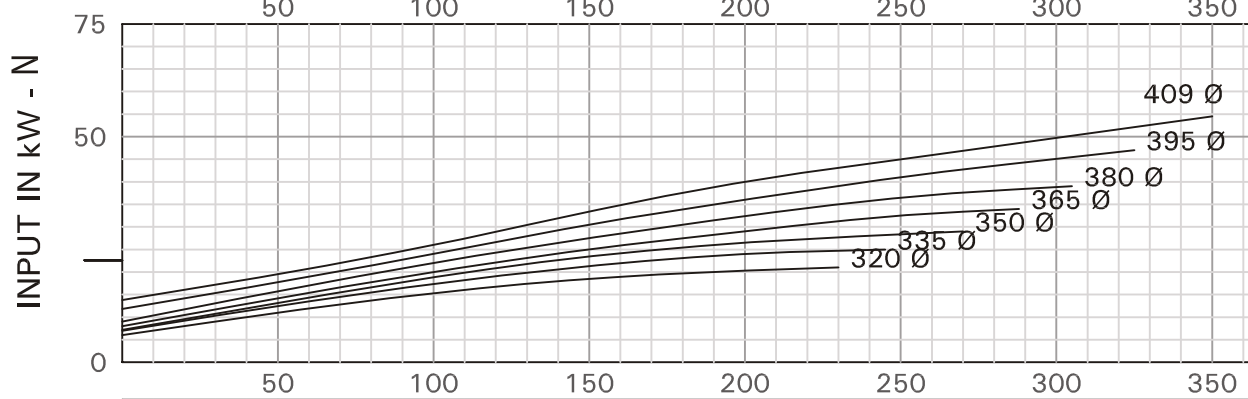
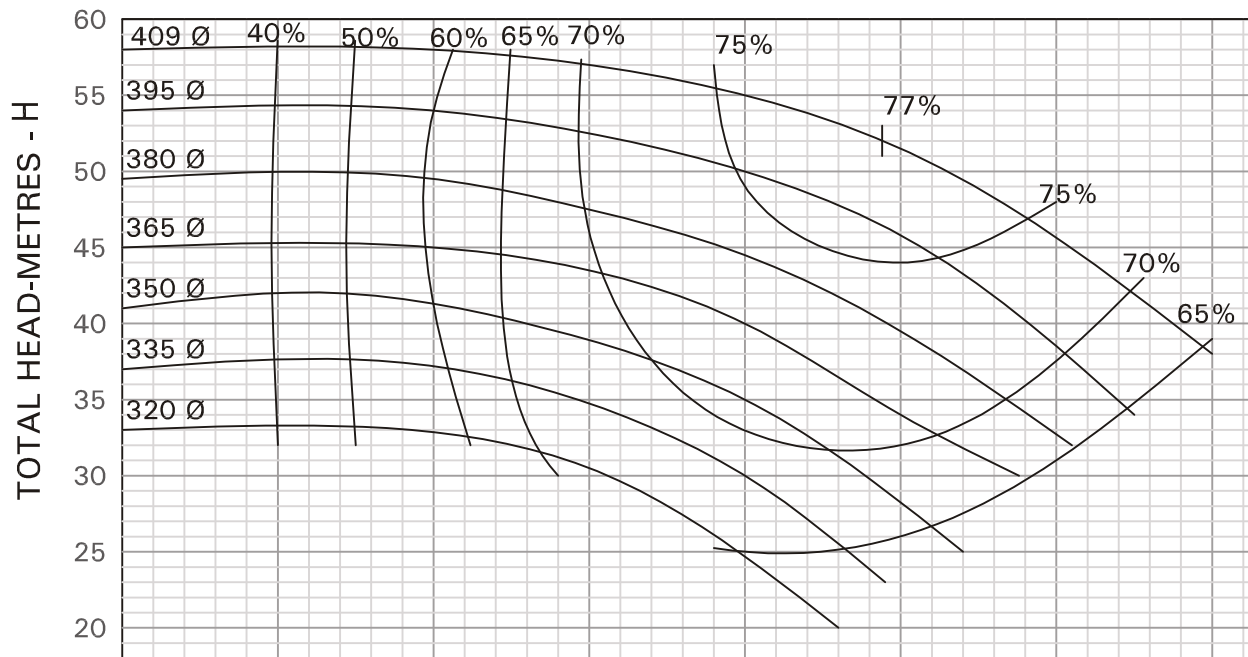

RECOMMENDED DELIVERY PIPE SIZE mm	125	150	175	200	225	250
RECOMMENDED SUCTION PIPE SIZE mm	150	175	200	225	250	275

# KIRLOSKAR BROTHERS LIMITED

NO. HD10229B0

## PERFORMANCE CURVE OF PUMP DB 150/32

SUC. 200 mm DEL 150 mm

THIS CURVE RELATES TO LIQUID OF SP.GR. = 1.0

n = 1450<sup>rpm</sup>  
(NOMINAL)



Enriching Lives

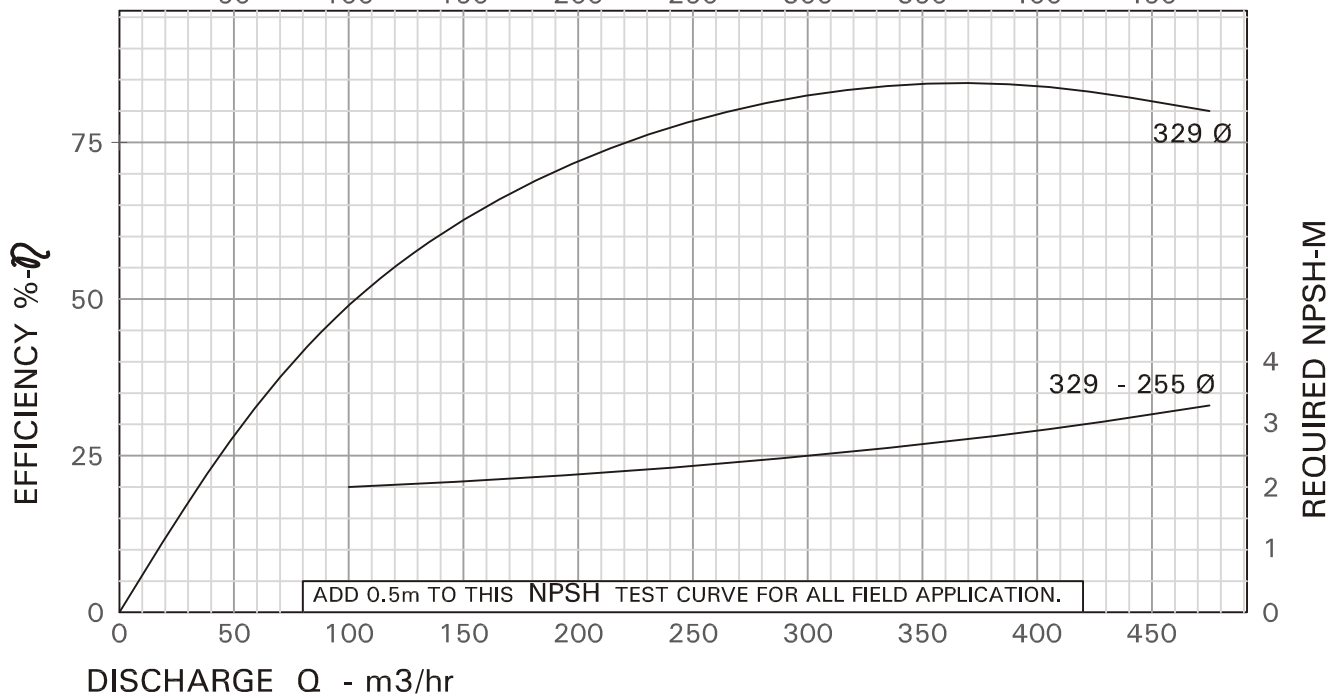
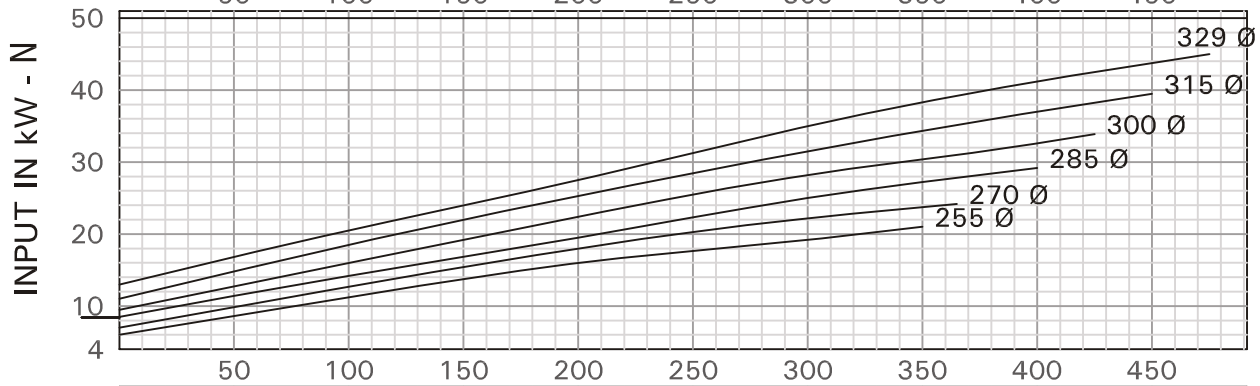
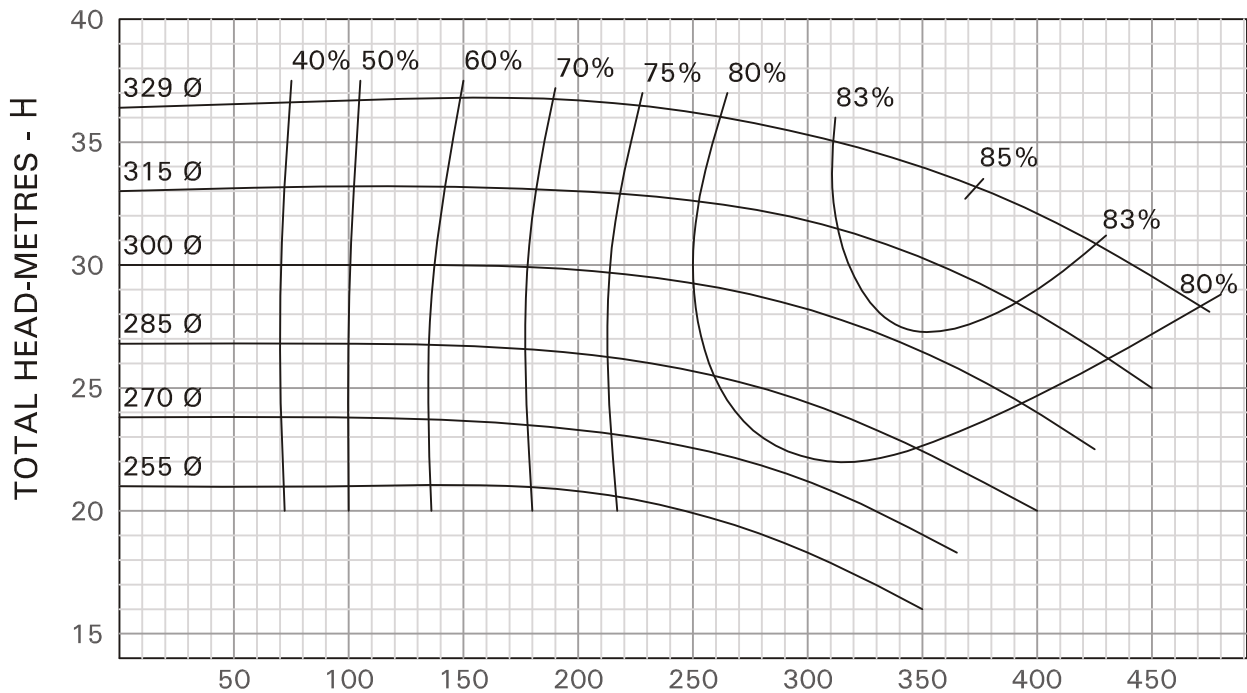

RECOMMENDED DELIVERY PIPE SIZE mm	125	150	175	200	225	250	275	
RECOMMENDED SUCTION PIPE SIZE mm	150	175	200	225	250	275	300	

# KIRLOSKAR BROTHERS LIMITED

NO. HD10230B0

## PERFORMANCE CURVE OF PUMP DB 150/40

SUC. 200 mm DEL. 150 mm

THIS CURVE RELATES TO LIQUID OF SP.GR. = 1.0

n = 1450rpm  
(NOMINAL)



Enriching Lives

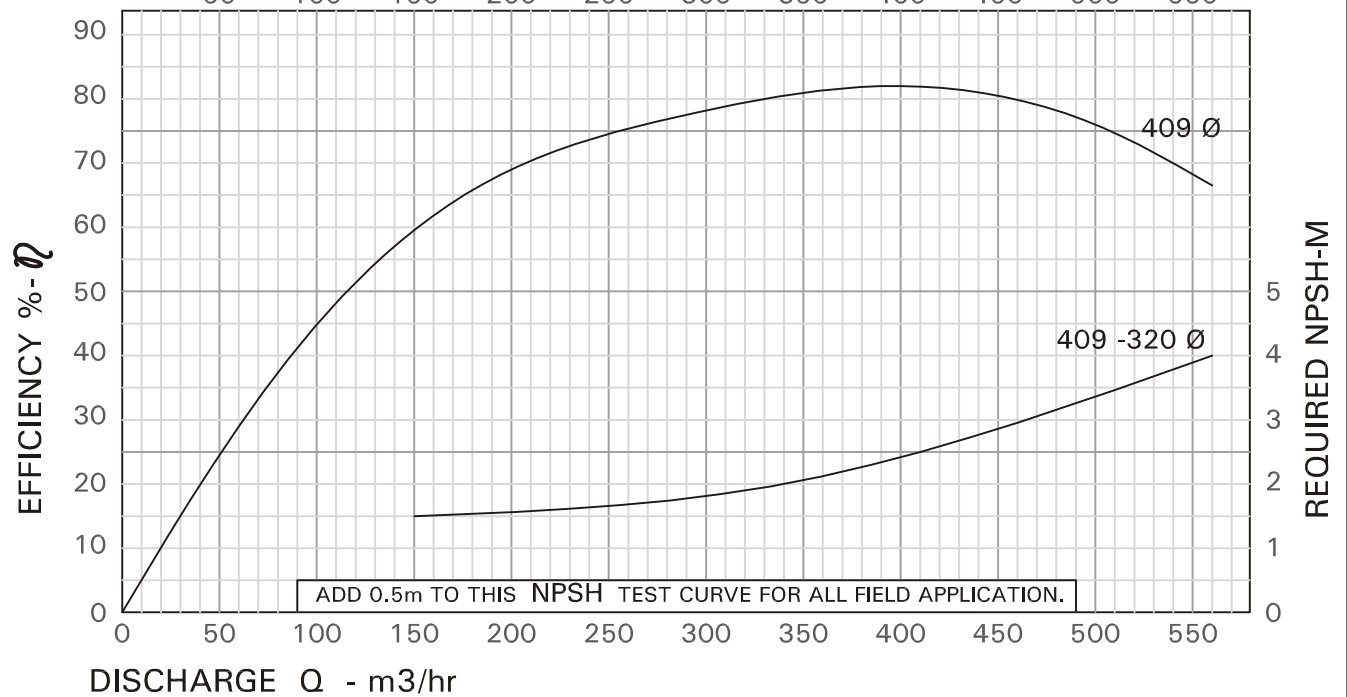
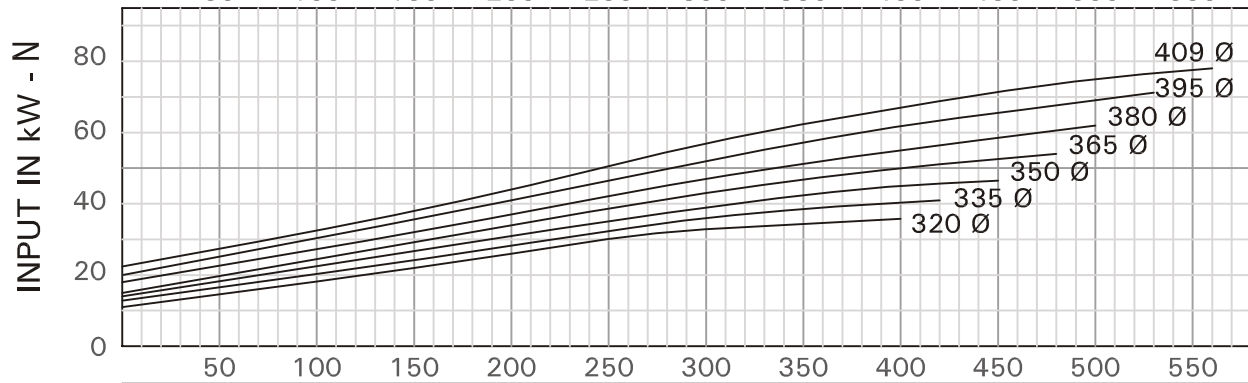
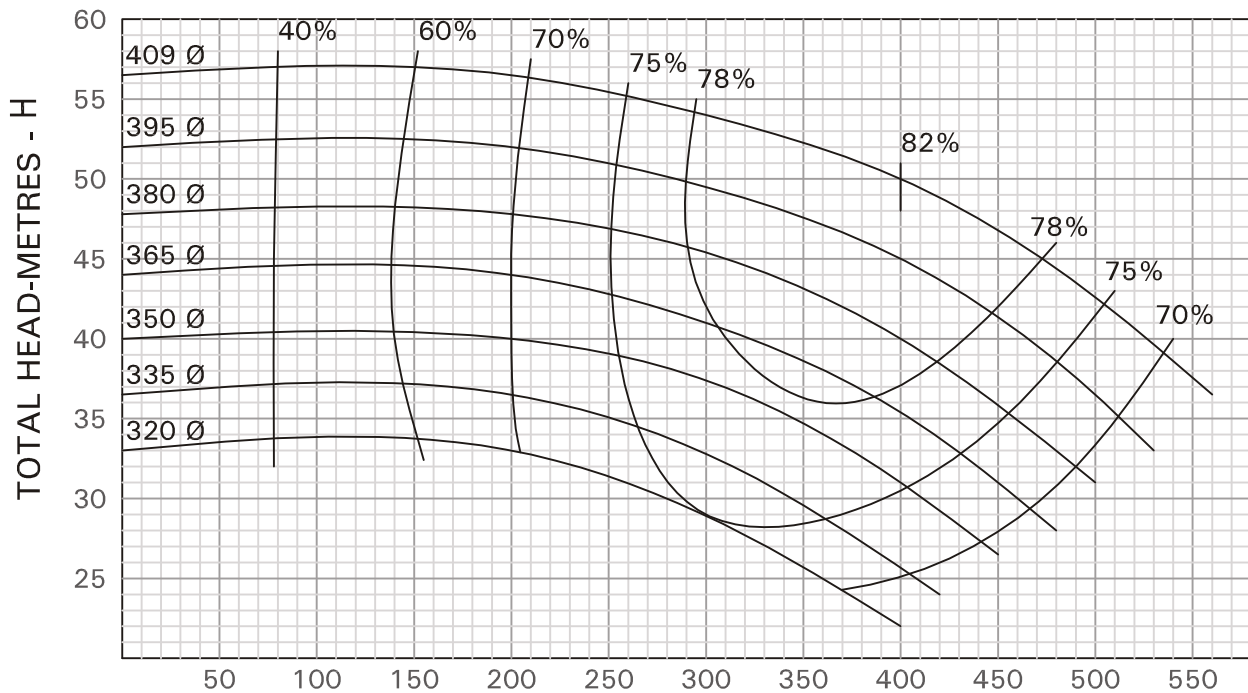

RECOMMENDED DELIVERY PIPE SIZE mm	150	175	200	225	250	275	
RECOMMENDED SUCTION PIPE SIZE mm	175	200	225	250	275	300	

# KIRLOSKAR BROTHERS LIMITED

NO. HD10201A0

## PERFORMANCE CURVE OF PUMP DB 32/13

SUC. 50 mm DEL 32 mm

THIS CURVE RELATES TO LIQUID OF SP.GR. = 1.0

n = 2900 rpm  
(NOMINAL)



Enriching Lives

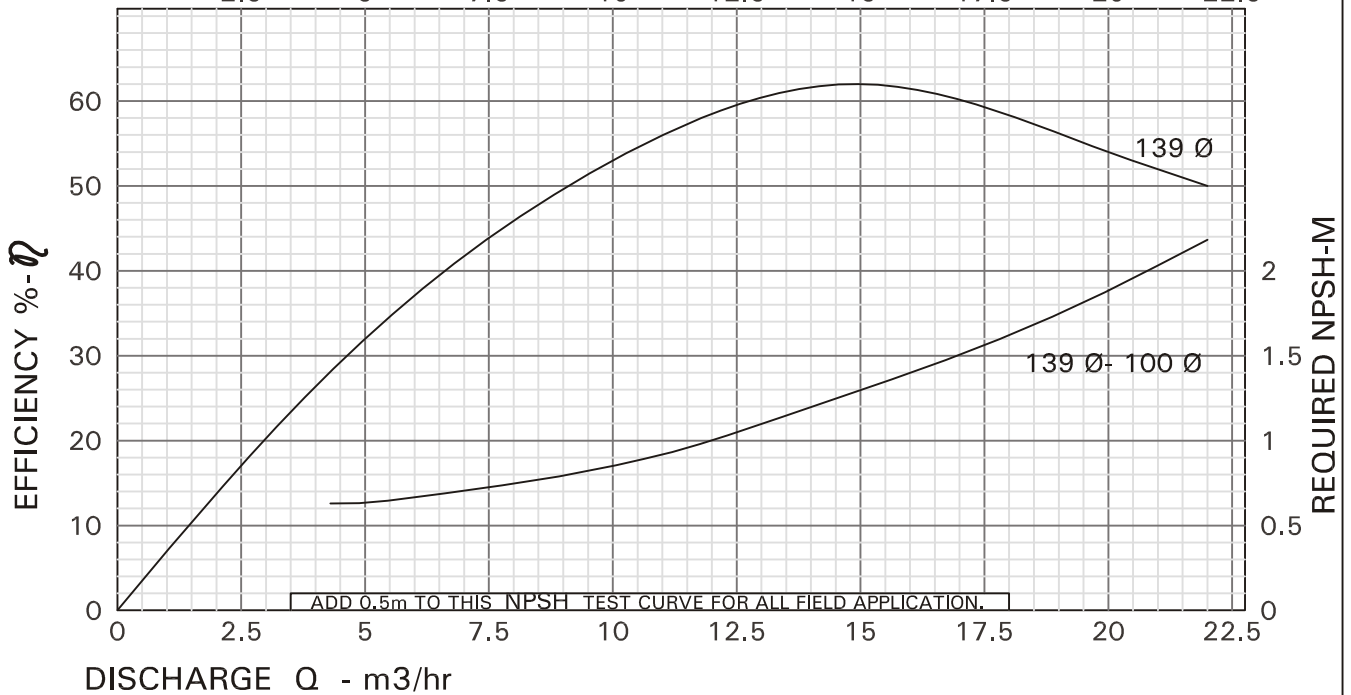
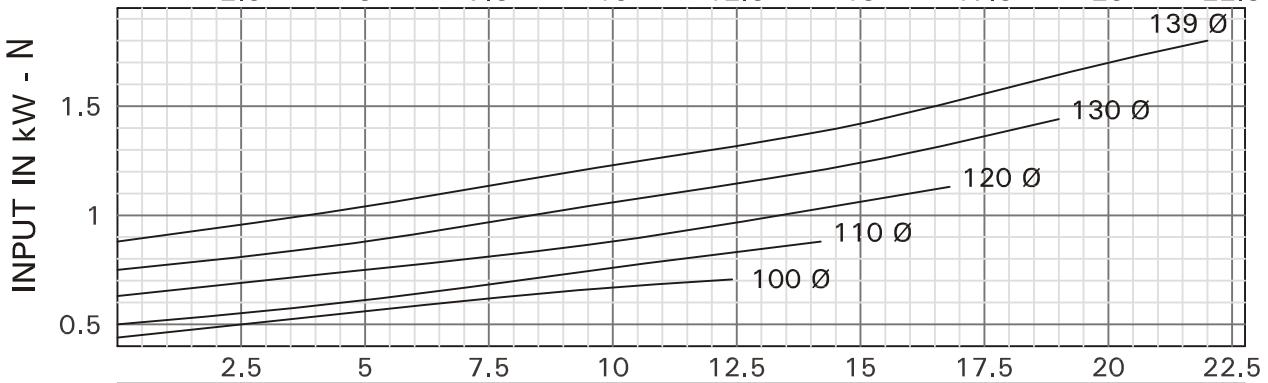
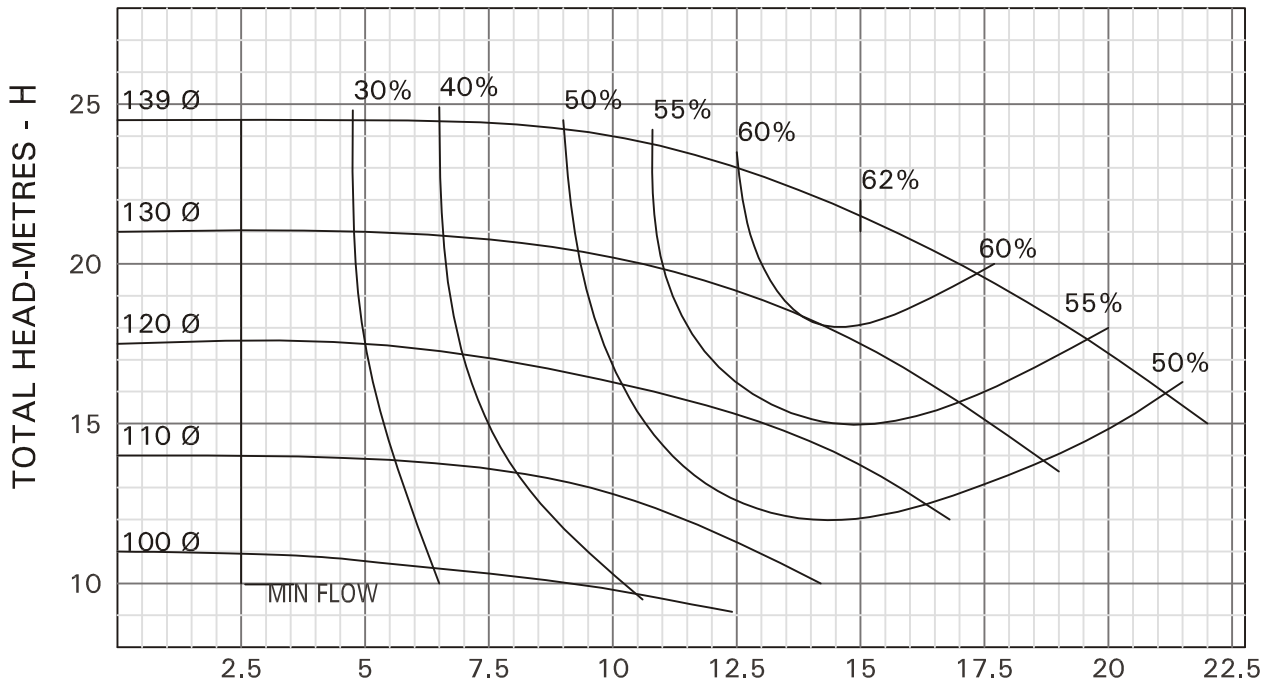

RECOMMENDED DELIVERY PIPE SIZE mm	50	65	80
RECOMMENDED SUCTION PIPE SIZE mm	50	65	80

# KIRLOSKAR BROTHERS LIMITED

NO. HD10202AO



## PERFORMANCE CURVE OF PUMP DB32/16

SUC. 50 mm DEL 32mm

THIS CURVE RELATES TO LIQUID OF SP.GR. = 1.0

n = 2900<sup>rpm</sup>  
(NOMINAL)

Enriching Lives

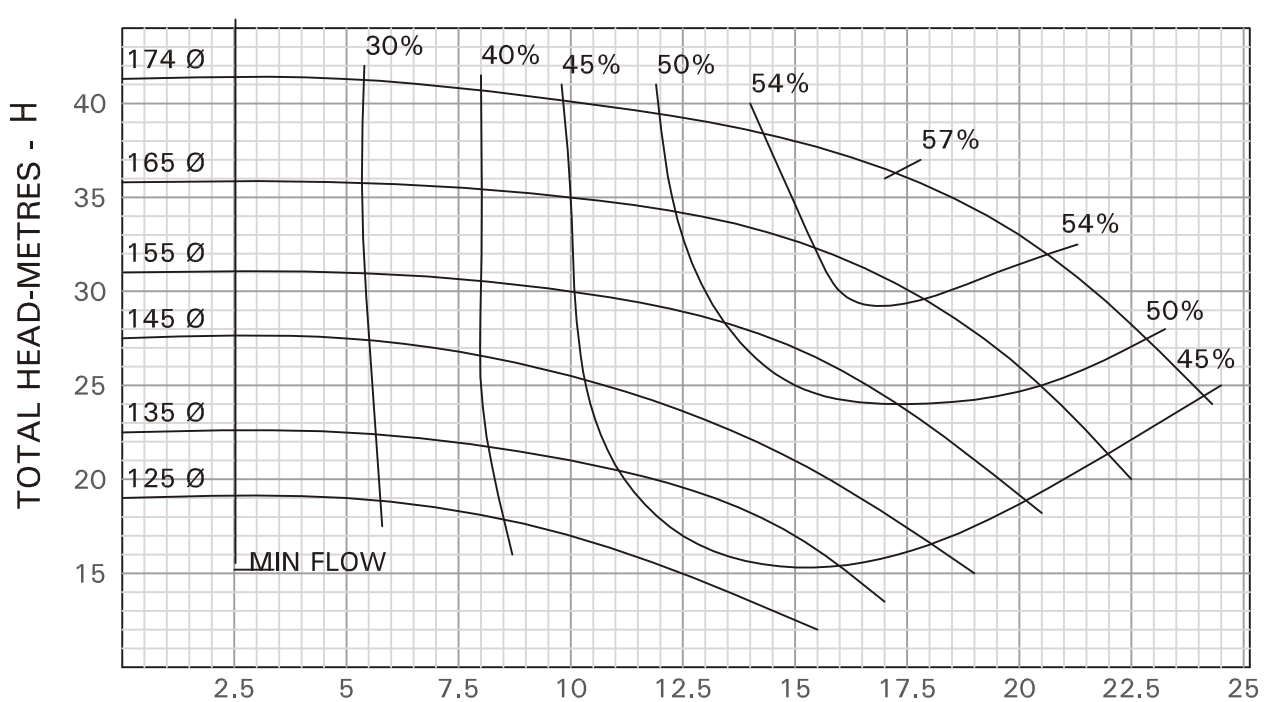

TOTAL HEAD- FEET LIQUID COLUMN-H

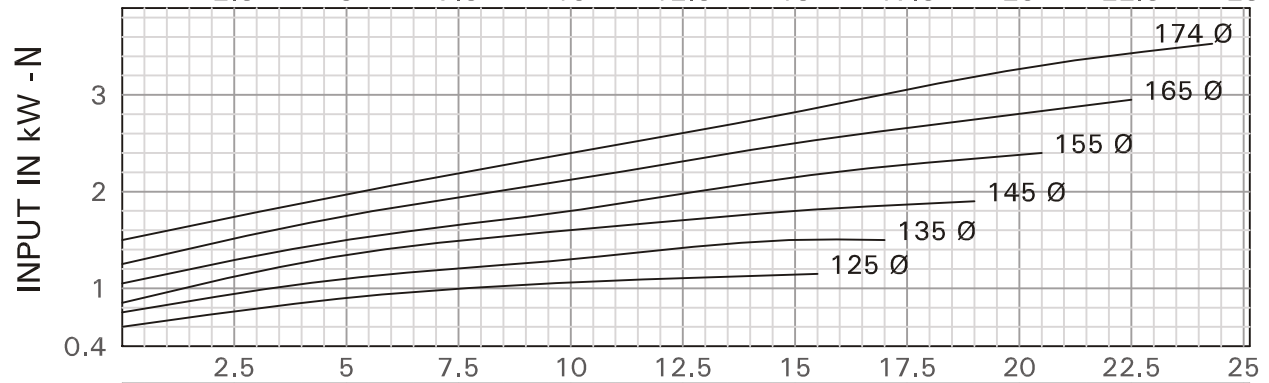

BRAKE HORSE POWER-N

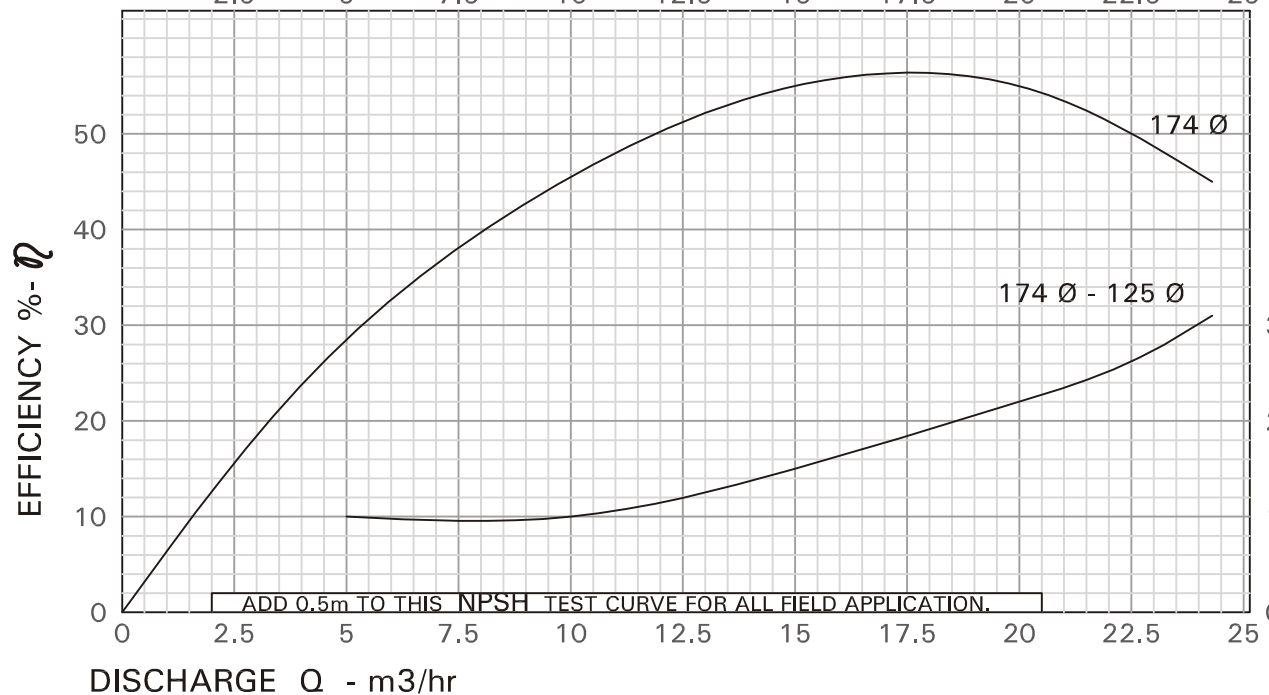

REQUIRED NPSH-M

DISCHARGE Q - m3/hr

RECOMMENDED DELIVERY PIPE SIZE mm	50	65	80
RECOMMENDED SUCTION PIPE SIZE mm	50	65	80

# KIRLOSKAR BROTHERS LIMITED

NO. HD10203AO

## PERFORMANCE CURVE OF PUMP DB 32/20

SUC. 50 mm DEL 32 mm

THIS CURVE RELATES TO LIQUID OF SP.GR. = 1.0

n = 2900 rpm  
(NOMINAL)



Enriching Lives

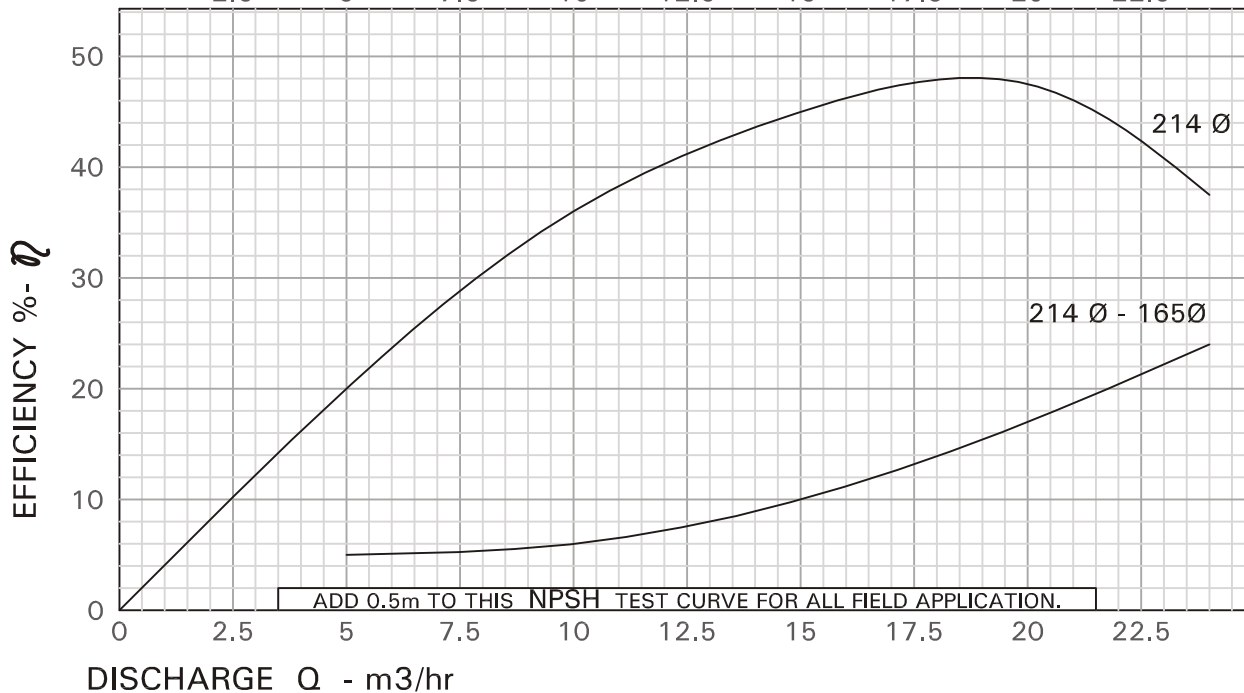
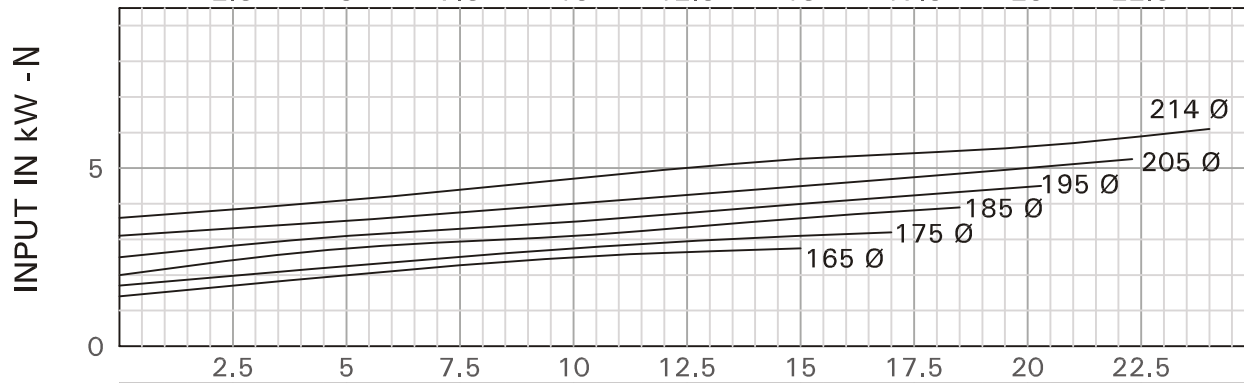
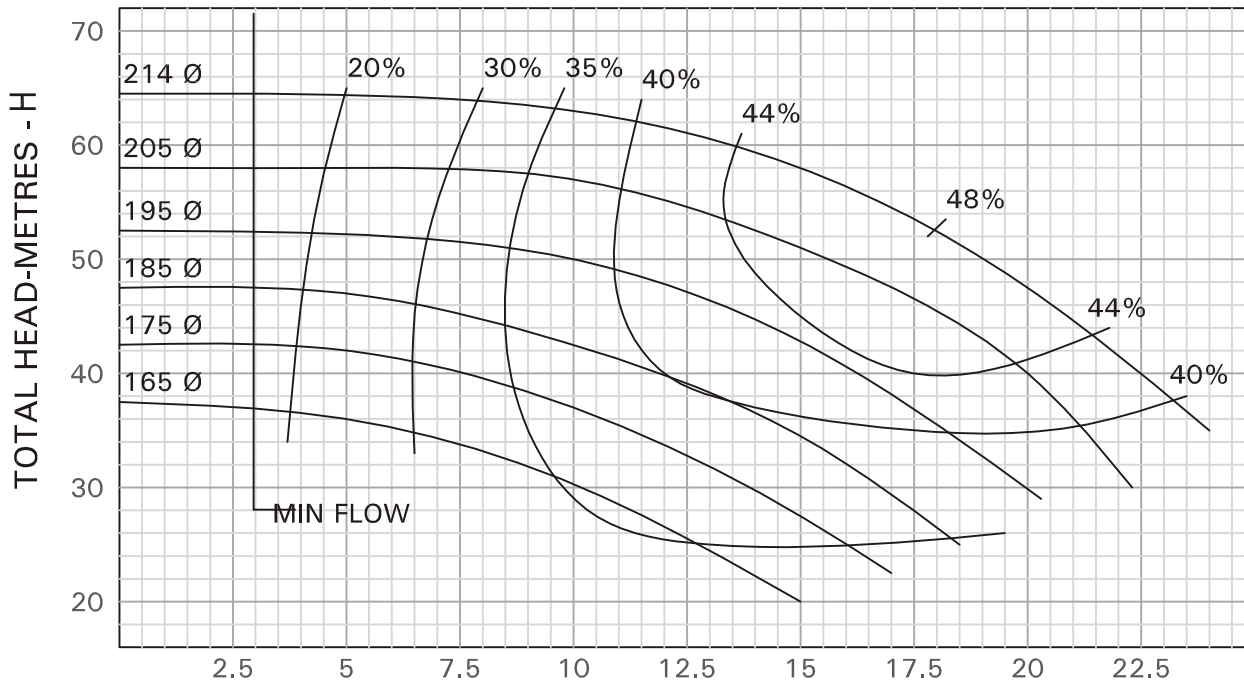

REQUIRED NPSH-M

RECOMMENDED DELIVERY PIPE SIZE mm	50	65	80	
RECOMMENDED SUCTION PIPE SIZE mm	50	65	80	100

# KIRLOSKAR BROTHERS LIMITED

NO. HD10204AO

## PERFORMANCE CURVE OF PUMP DB 32/26

SUC. 50 mm DEL 32mm

THIS CURVE RELATES TO LIQUID OF SP.GR. = 1.0

n = 2900<sup>rpm</sup>  
(NOMINAL)



Enriching Lives

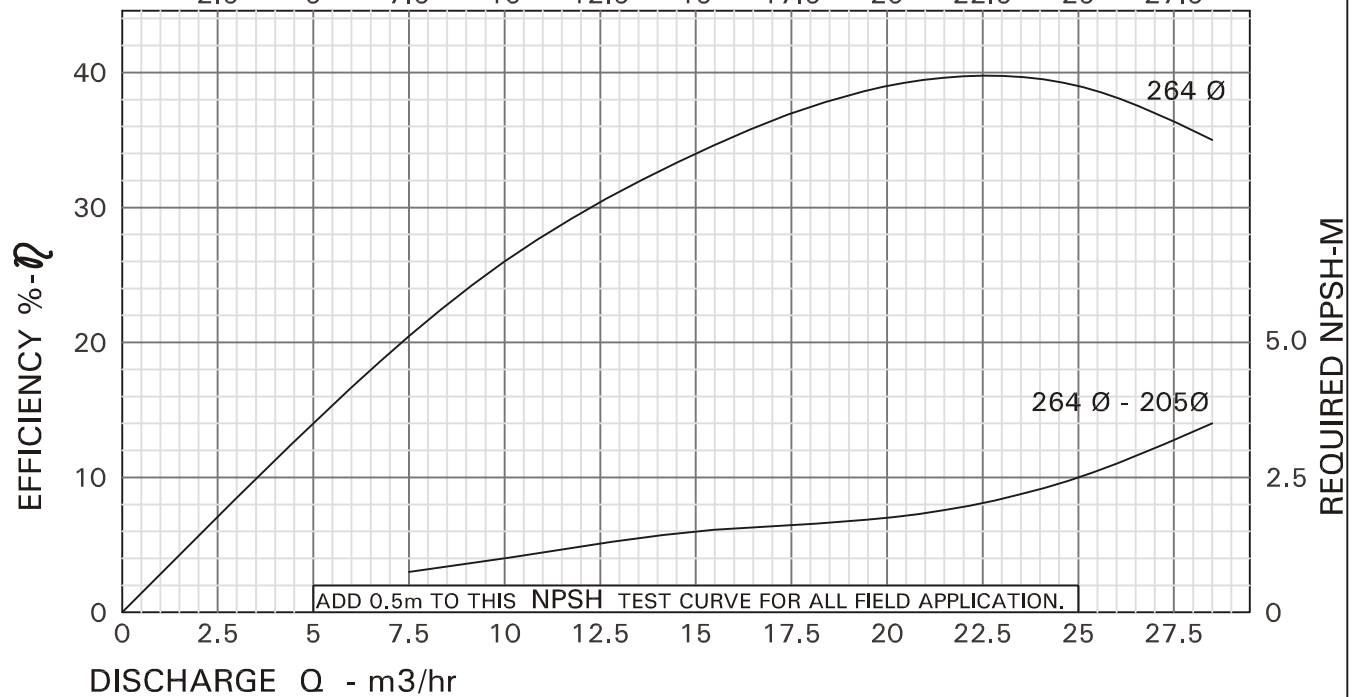
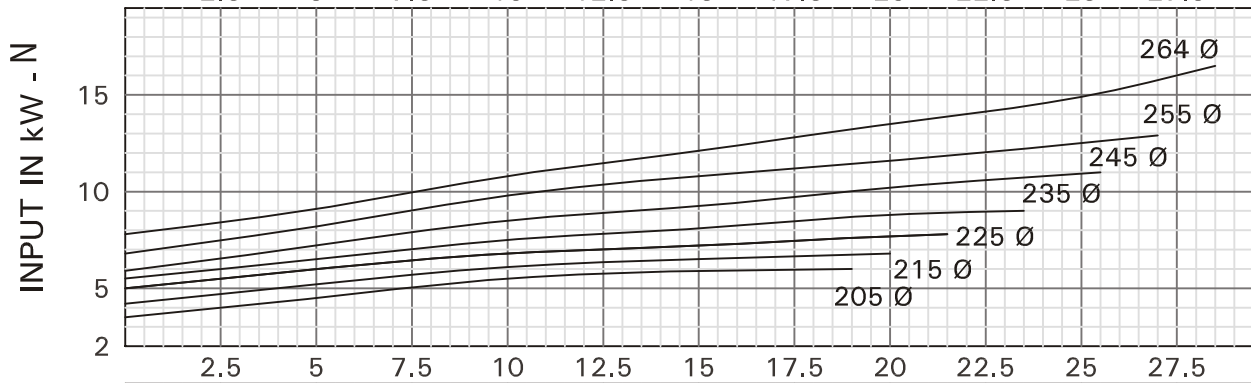
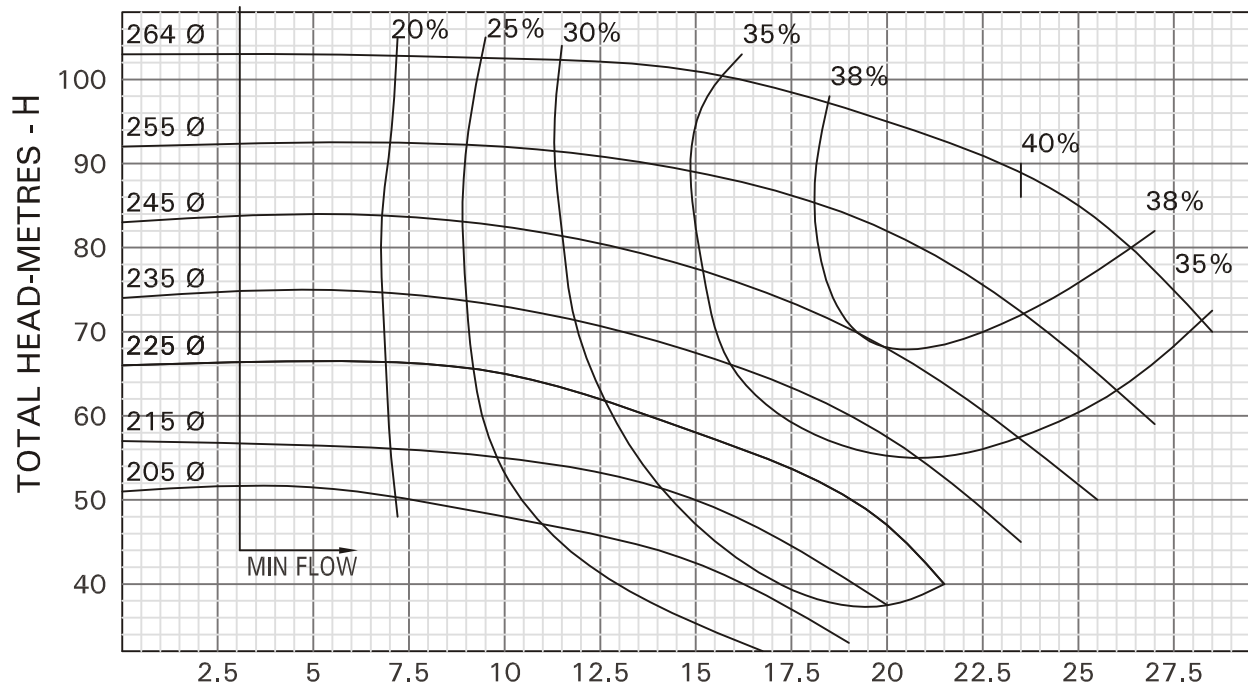

RECOMMENDED DELIVERY PIPE SIZE mm	50	65	80	100
RECOMMENDED SUCTION PIPE SIZE mm	50	65	80	100

# KIRLOSKAR BROTHERS LIMITED

NO. HD10205AO

## PERFORMANCE CURVE OF PUMP DB 40/13

SUC. 65 mm DEL 40mm

THIS CURVE RELATES TO LIQUID OF SP.GR. = 1.0

n = 2900 rpm  
(NOMINAL)



Enriching Lives

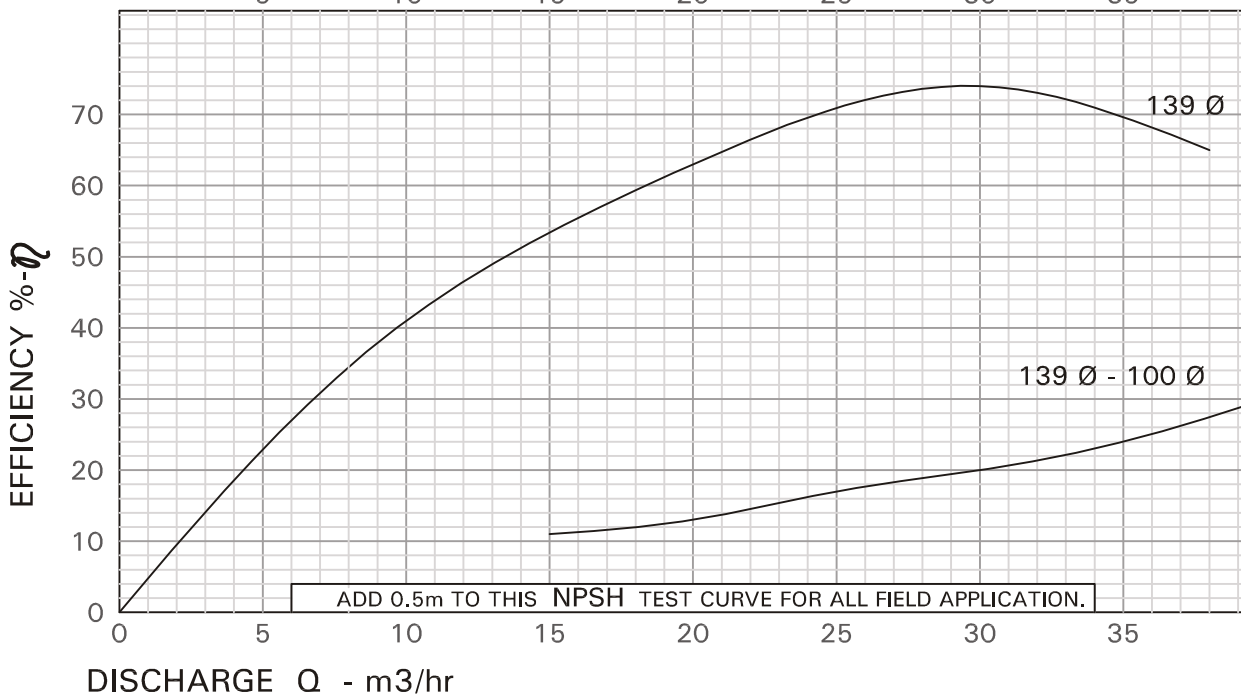
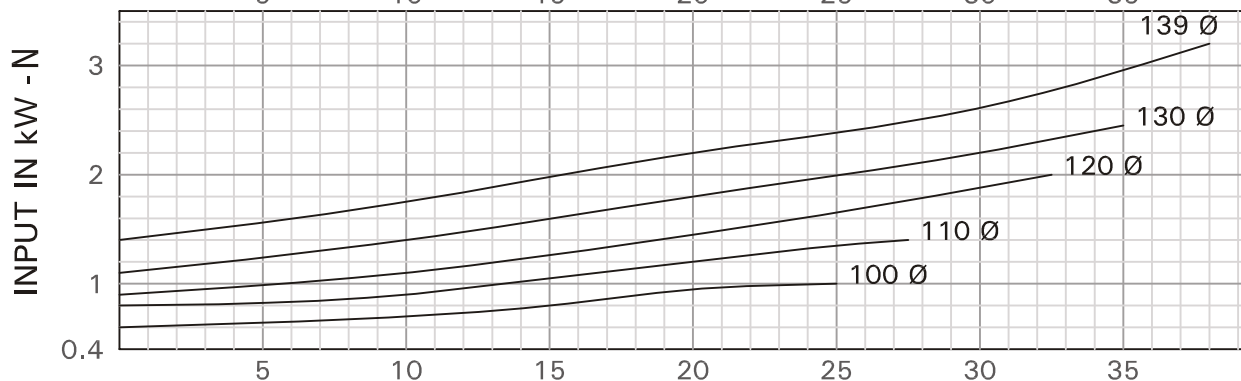
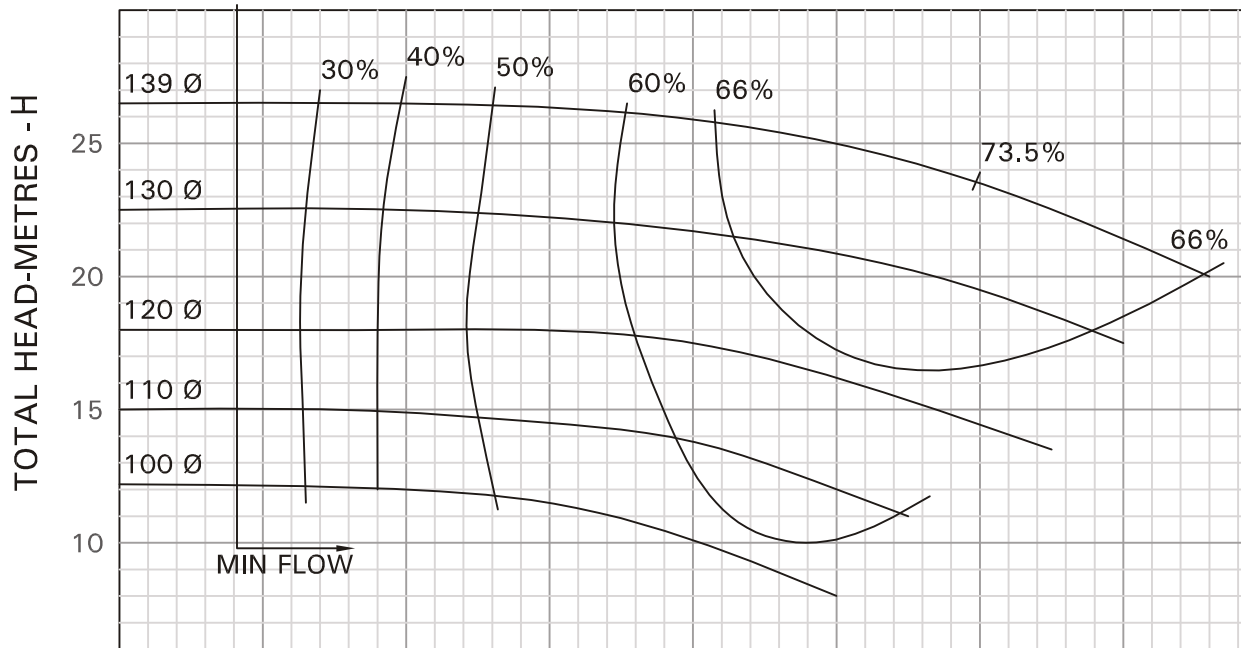

RECOMMENDED DELIVERY PIPE SIZE mm	50	65	80	100
RECOMMENDED SUCTION PIPE SIZE mm	50	65	80	100

# KIRLOSKAR BROTHERS LIMITED

NO. HD10206AO

## PERFORMANCE CURVE OF PUMP DB 40/16

SUC. 65 mm DEL 40mm

THIS CURVE RELATES TO LIQUID OF SP.GR. = 1.0

n = 2900<sup>rpm</sup>  
(NOMINAL)



Enriching Lives

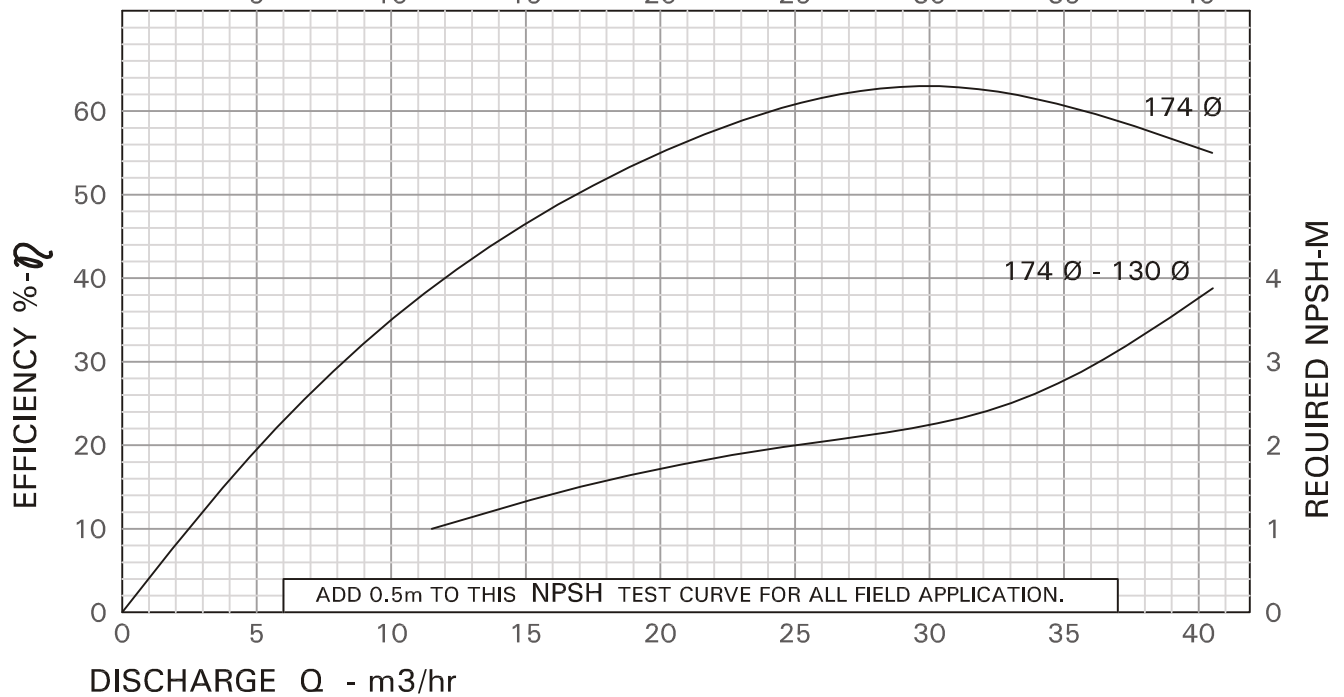
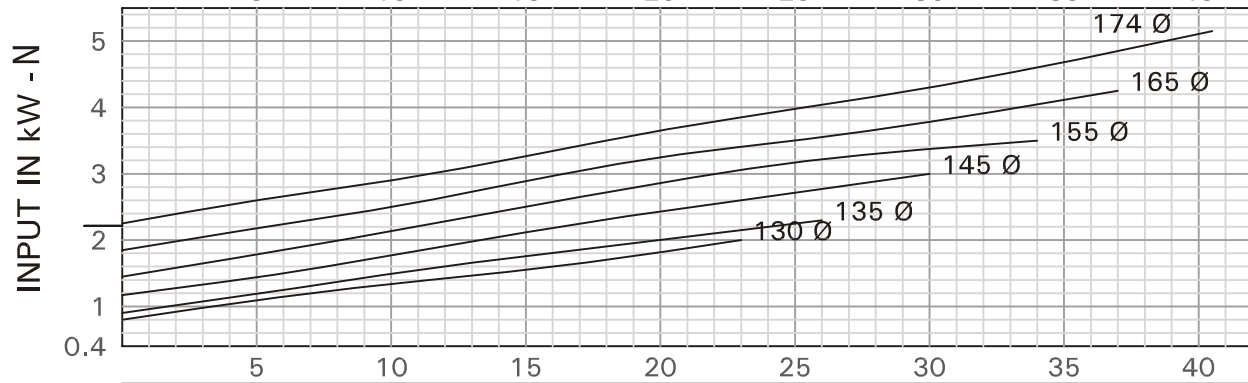
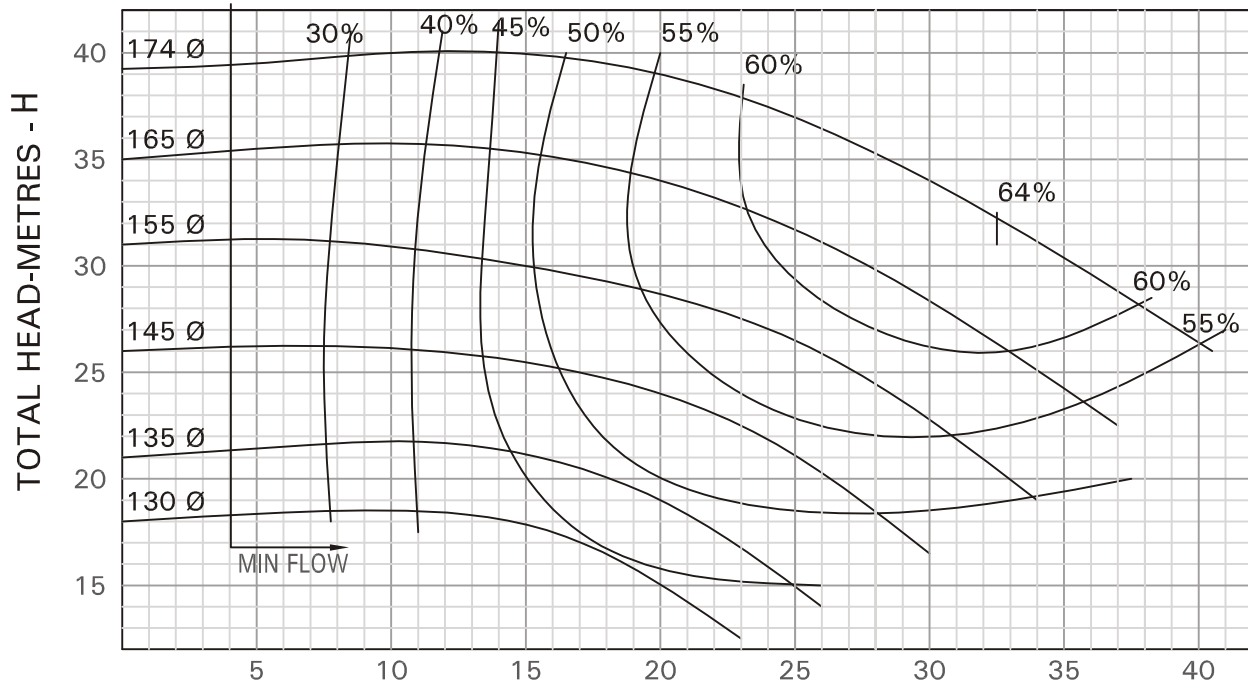

RECOMMENDED DELIVERY PIPE SIZE mm	50	65		80	
RECOMMENDED SUCTION PIPE SIZE mm	50	65	80	100	

# KIRLOSKAR BROTHERS LIMITED

NO. HD10207AO

## PERFORMANCE CURVE OF PUMP DB 40/20

SUC. 65 mm DEL 40mm

THIS CURVE RELATES TO LIQUID OF SP.GR. = 1.0

n = 2900<sup>rpm</sup>  
(NOMINAL)



Enriching Lives

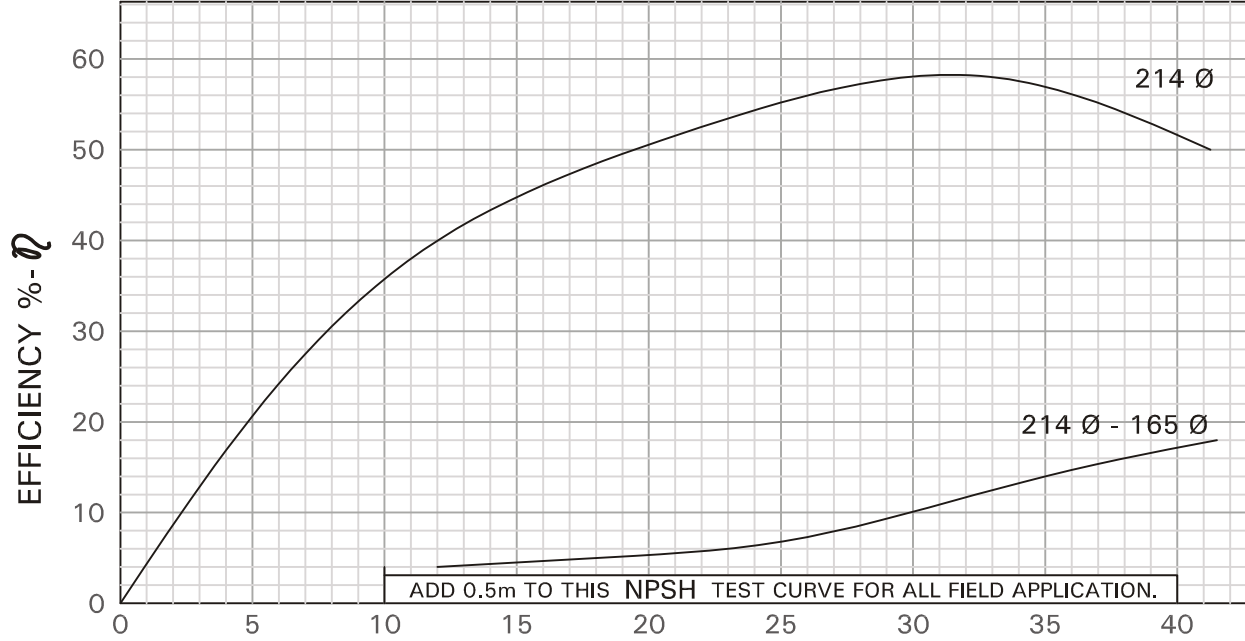
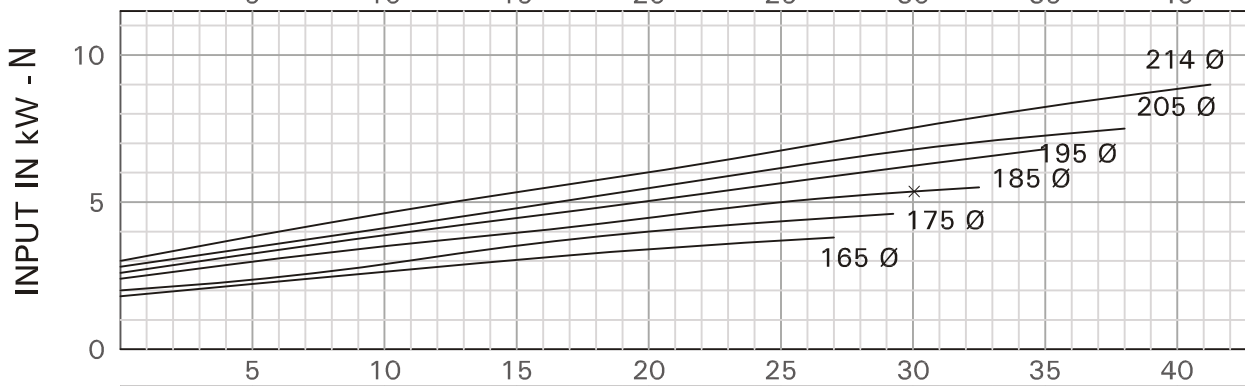
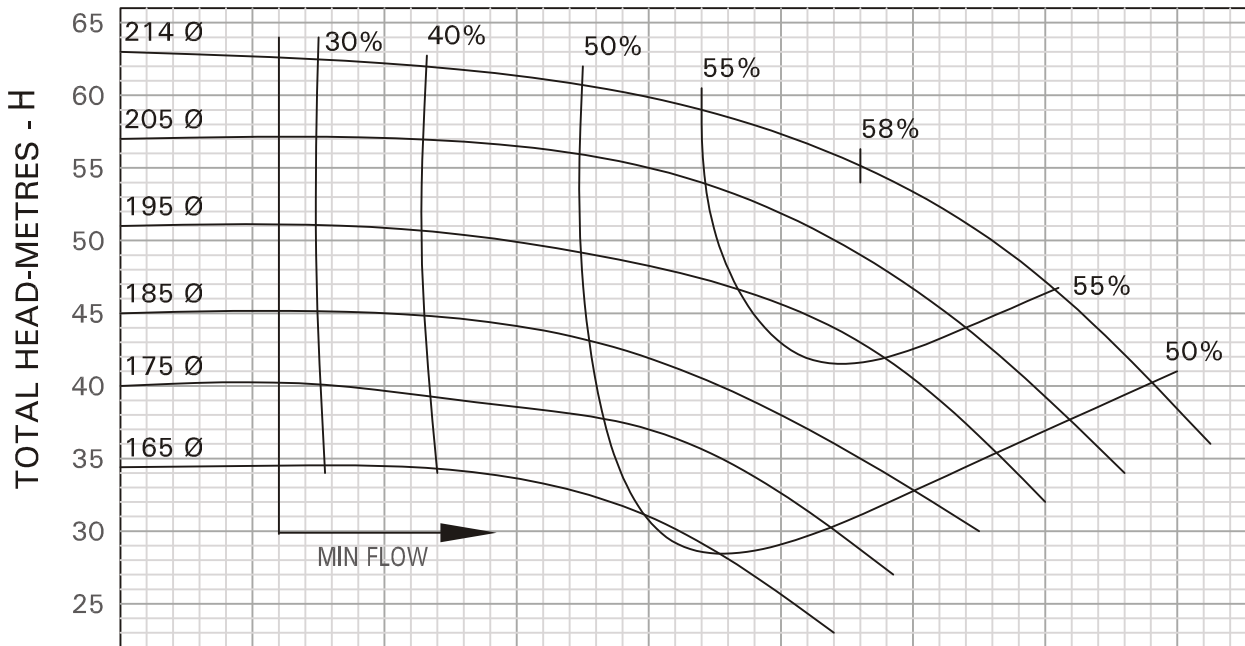

REQUIRED NPSH-M

REQUIRED NPSH-M

RECOMMENDED DELIVERY PIPE SIZE mm	50	65	80	100	
RECOMMENDED SUCTION PIPE SIZE mm	65	80	100		

# KIRLOSKAR BROTHERS LIMITED

NO. HD10208AO

## PERFORMANCE CURVE OF PUMP DB 40/26

SUC. 65 mm DEL 40mm

THIS CURVE RELATES TO LIQUID OF SP.GR. = 1.0

n = 2900<sup>rpm</sup>  
(NOMINAL)



Enriching Lives

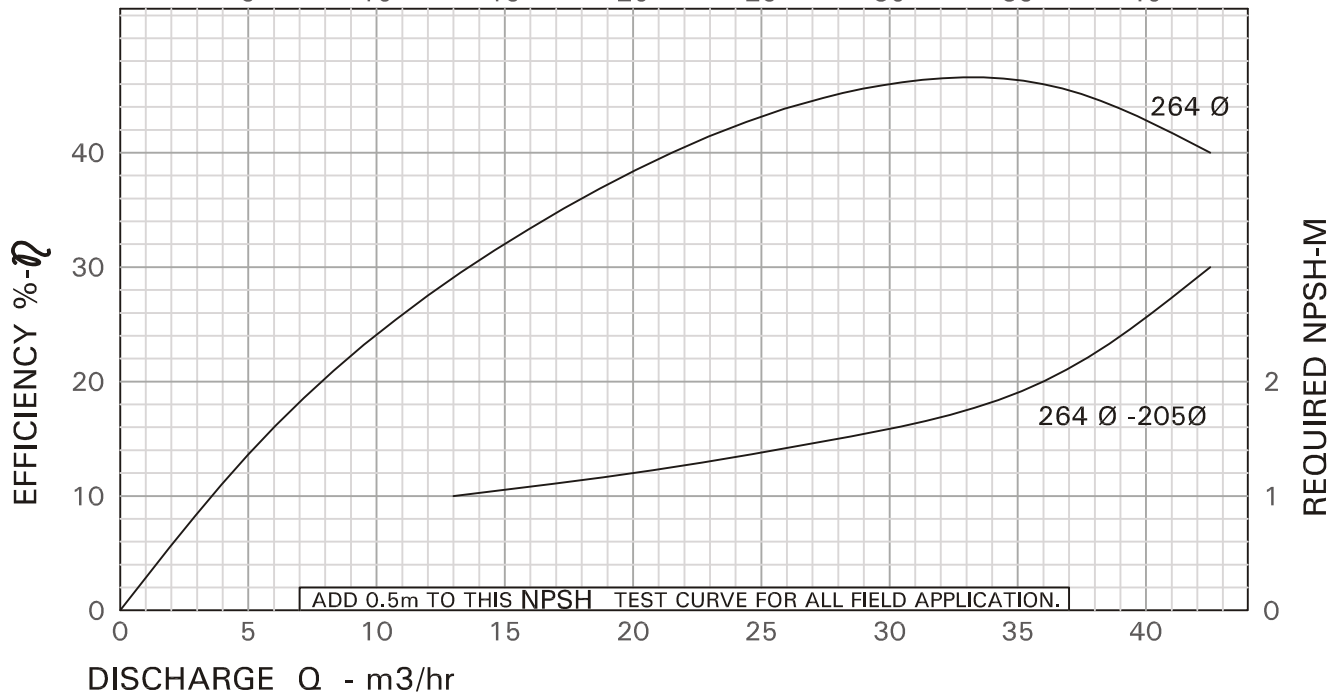
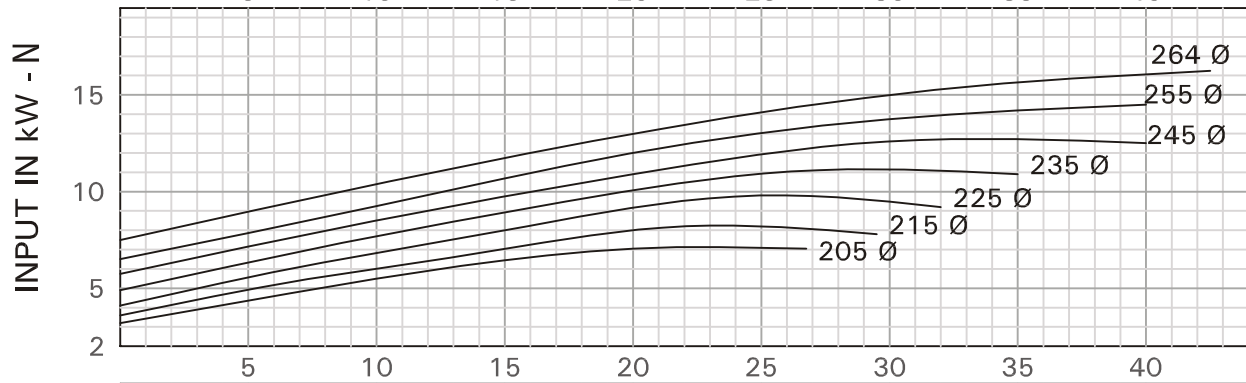
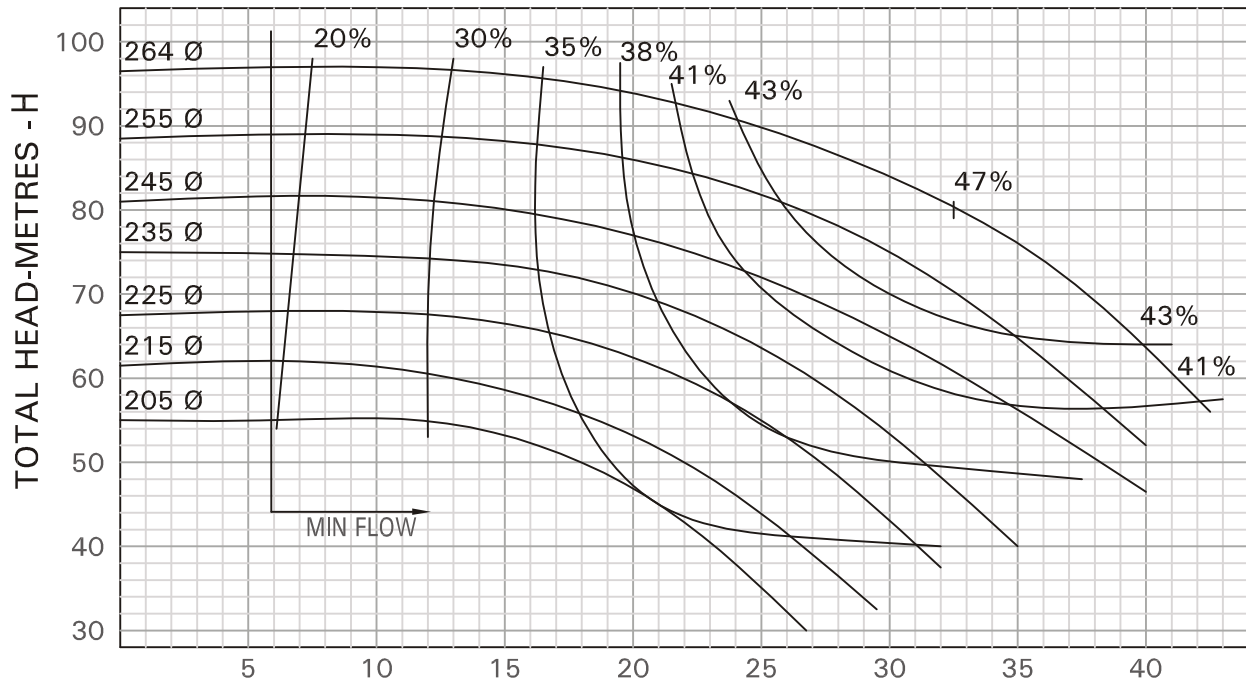

RECOMMENDED DELIVERY PIPE SIZE mm	50	65	80	100
RECOMMENDED SUCTION PIPE SIZE mm	65	80	100	

# KIRLOSKAR BROTHERS LIMITED

NO. HD10209AO

## PERFORMANCE CURVE OF PUMP DB 50/13

SUC. 65 mm DEL 50mm

THIS CURVE RELATES TO LIQUID OF SP.GR. = 1.0

n = 2900 rpm  
(NOMINAL)



Enriching Lives

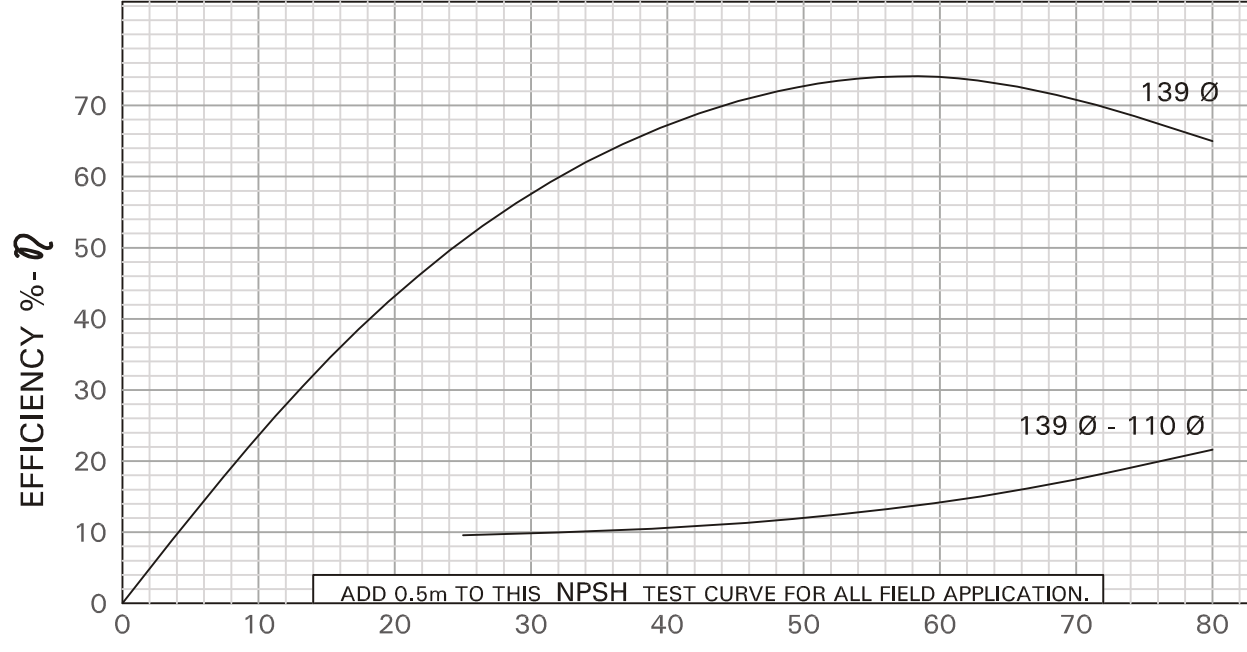
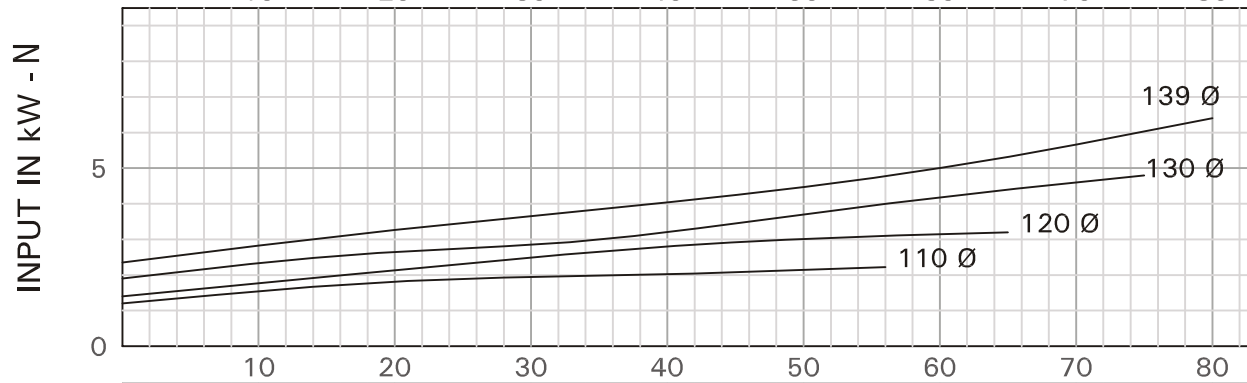
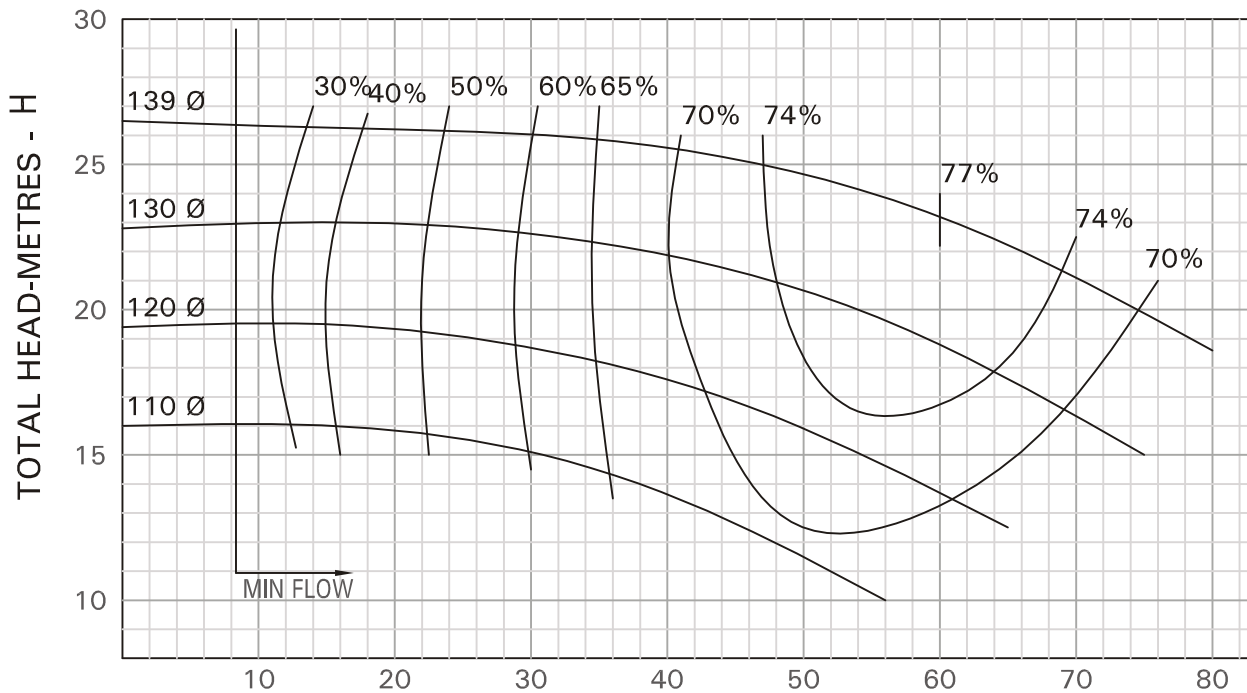

REQUIRED NPSH-M

DISCHARGE Q - m3/hr

RECOMMENDED DELIVERY PIPE SIZE mm	65	80	100	125
RECOMMENDED SUCTION PIPE SIZE mm	80	100	125	

# KIRLOSKAR BROTHERS LIMITED

NO. HD10210AO

## PERFORMANCE CURVE OF PUMP DB 50/16

SUC. 65 mm DEL 50mm

THIS CURVE RELATES TO LIQUID OF SP.GR. = 1.0

n = 2900 rpm  
(NOMINAL)



Enriching Lives

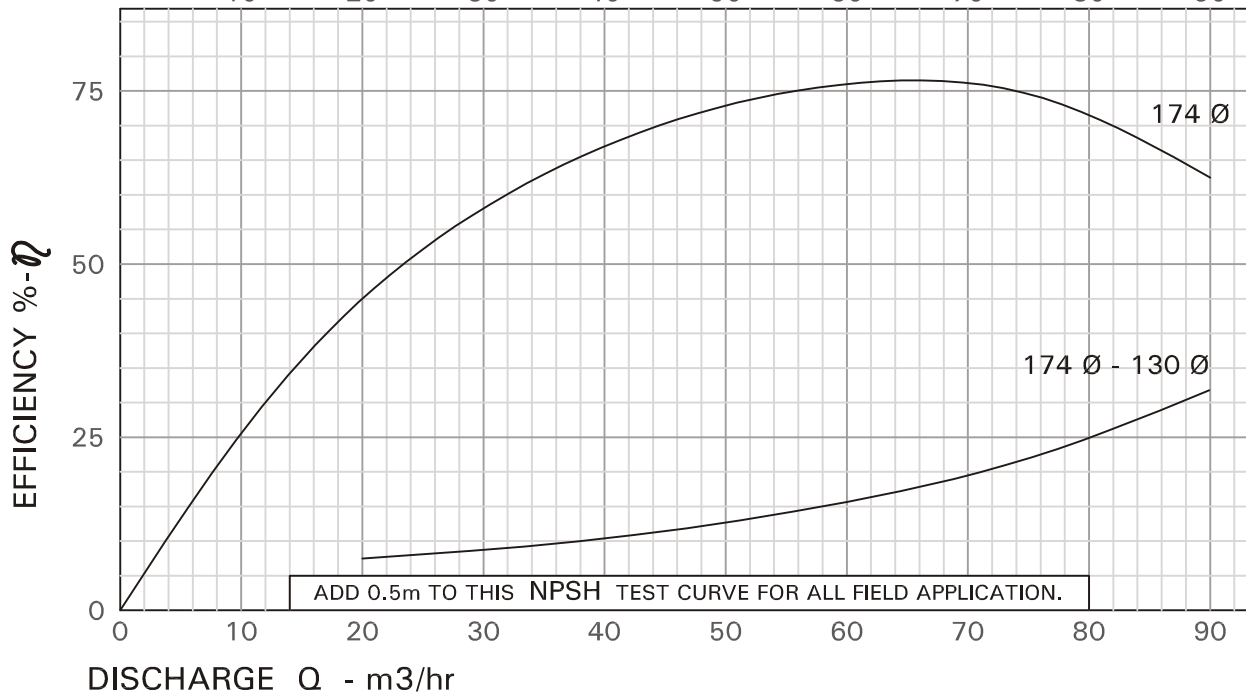
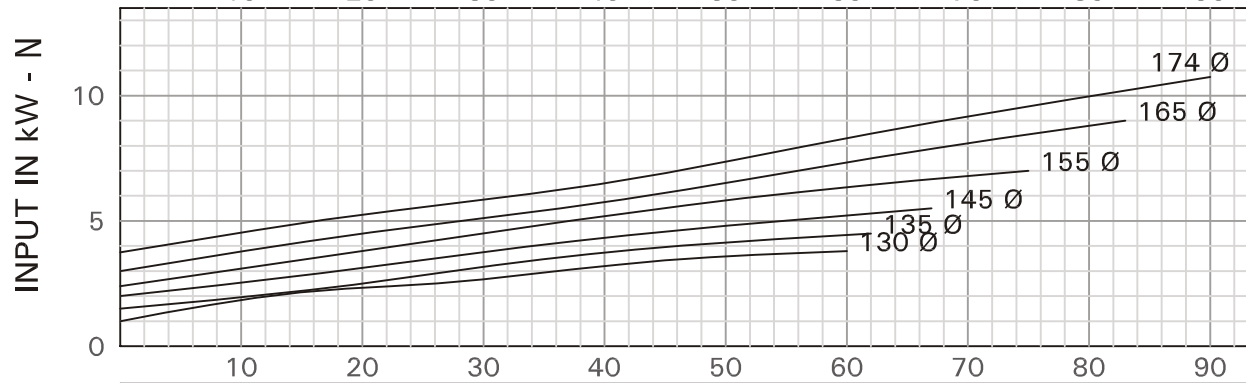
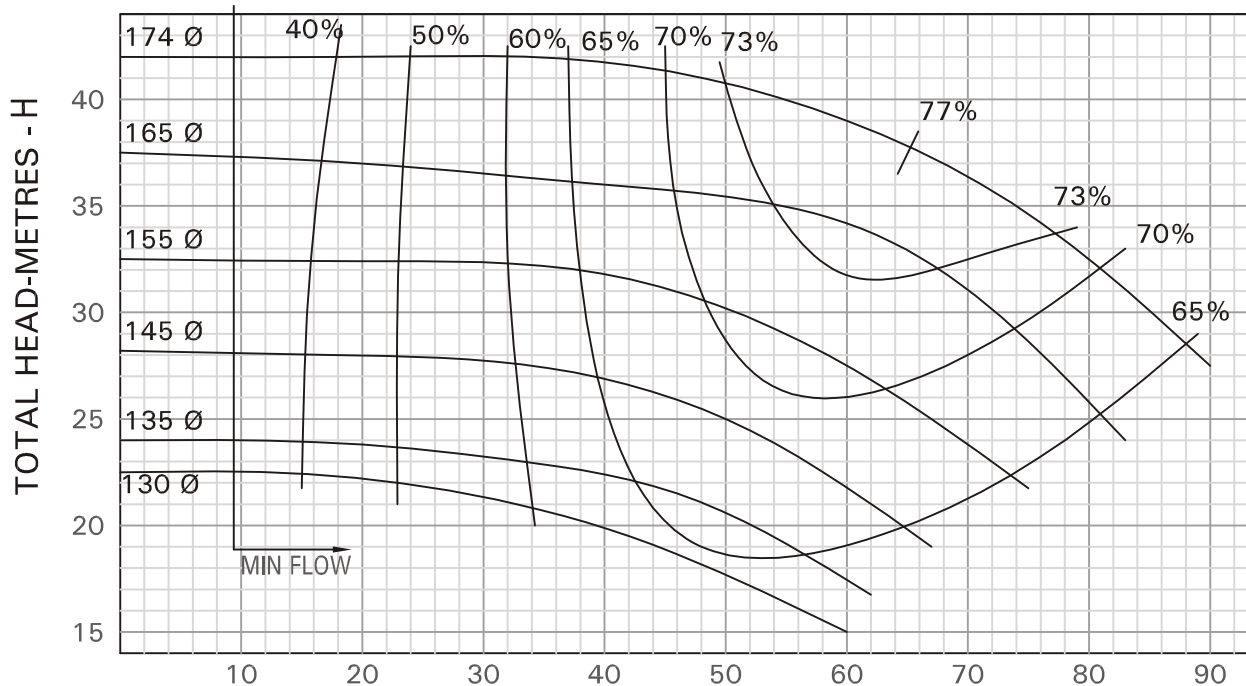

RECOMMENDED DELIVERY PIPE SIZE mm	50	65	80	
RECOMMENDED SUCTION PIPE SIZE mm		65	80	

# KIRLOSKAR BROTHERS LIMITED

NO. HD10211A0

## PERFORMANCE CURVE OF PUMP DB 50/20

SUC. 65 mm DEL 50mm

THIS CURVE RELATES TO LIQUID OF SP.GR. = 1.0

n = 2900<sup>rpm</sup>  
(NOMINAL)



Enriching Lives

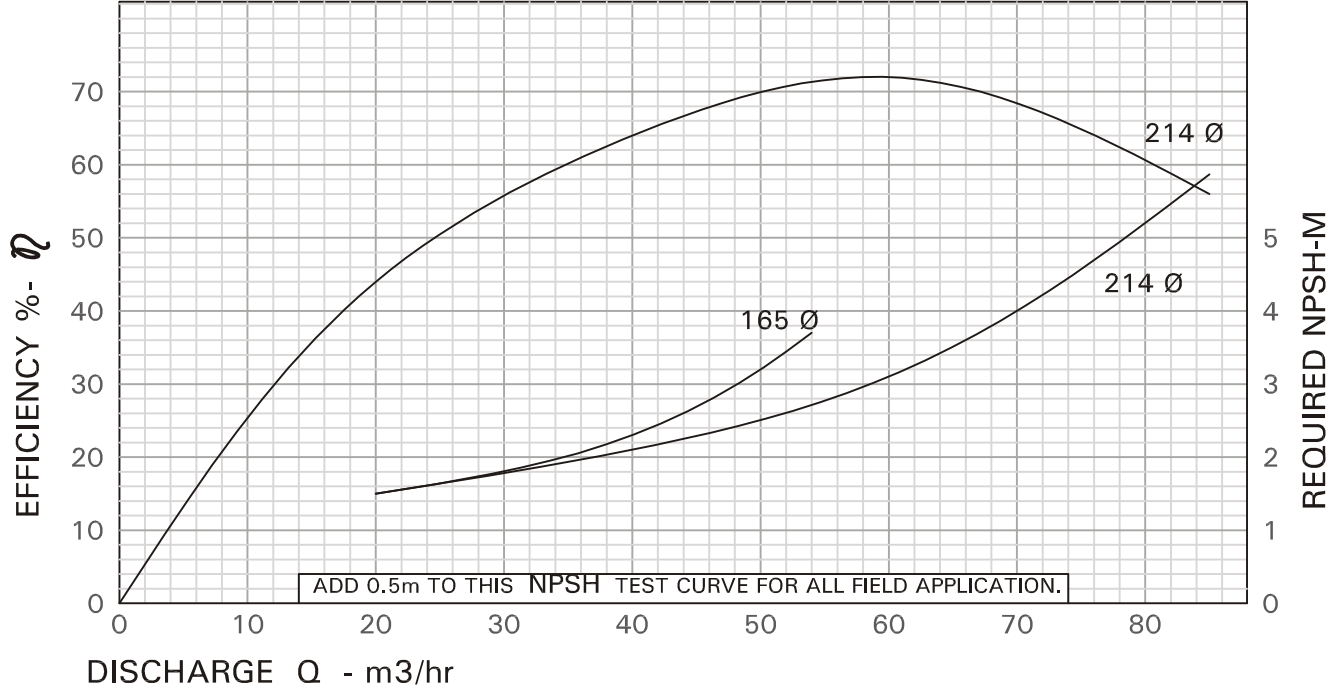
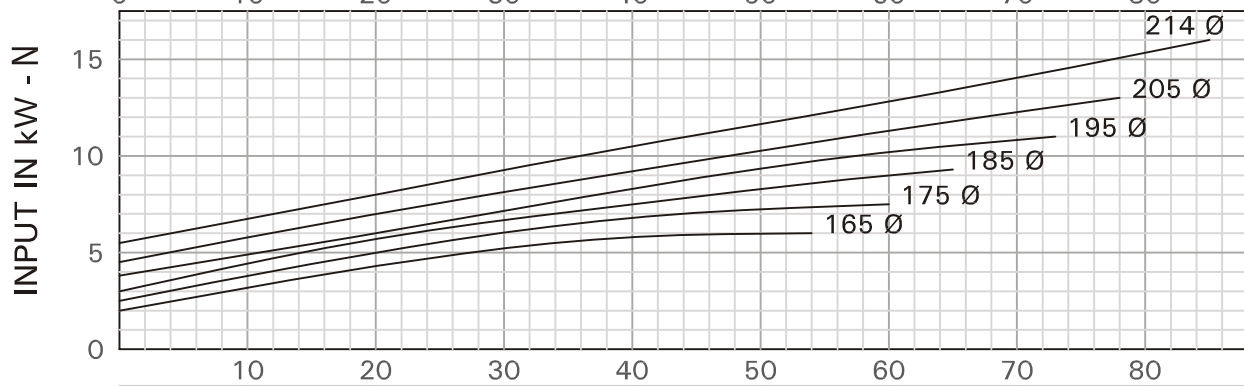
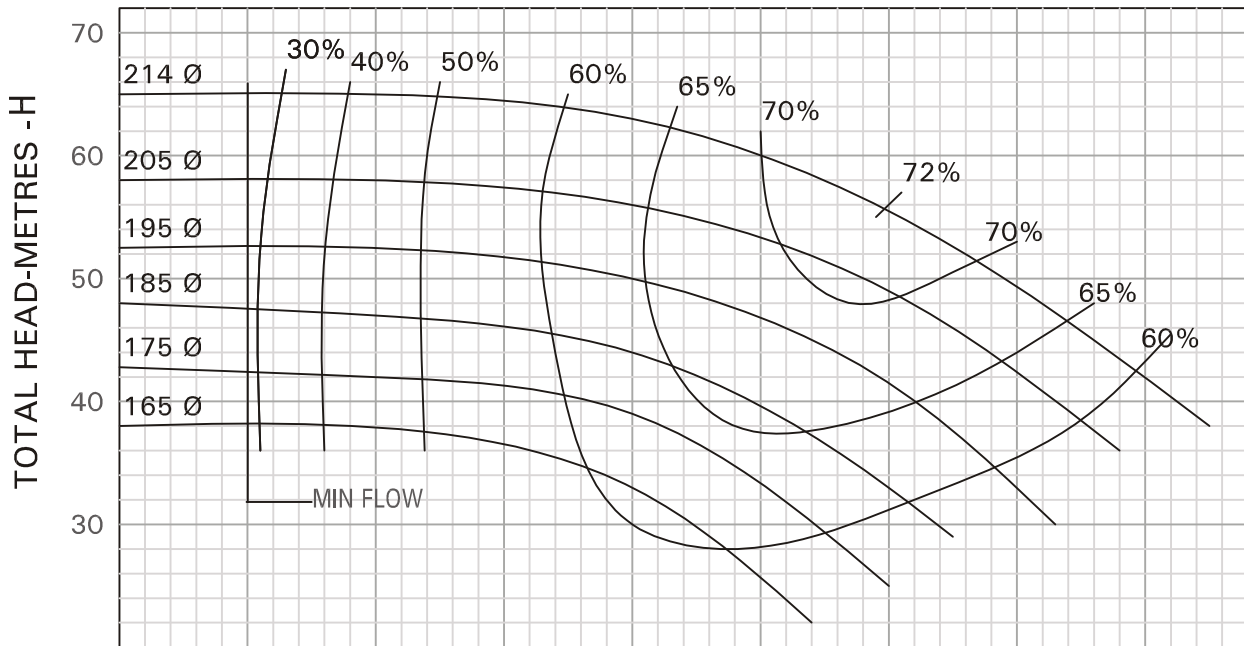

RECOMMENDED DELIVERY PIPE SIZE mm	65	80	100	125	
RECOMMENDED SUCTION PIPE SIZE mm	80	100	125	150	

# KIRLOSKAR BROTHERS LIMITED

NO. HD10212AO

## PERFORMANCE CURVE OF PUMP DB 50/26

SUC. 65 mm DEL 50 mm

THIS CURVE RELATES TO LIQUID OF SP.GR. = 1.0

n = 2900 rpm  
(NOMINAL)



Enriching Lives

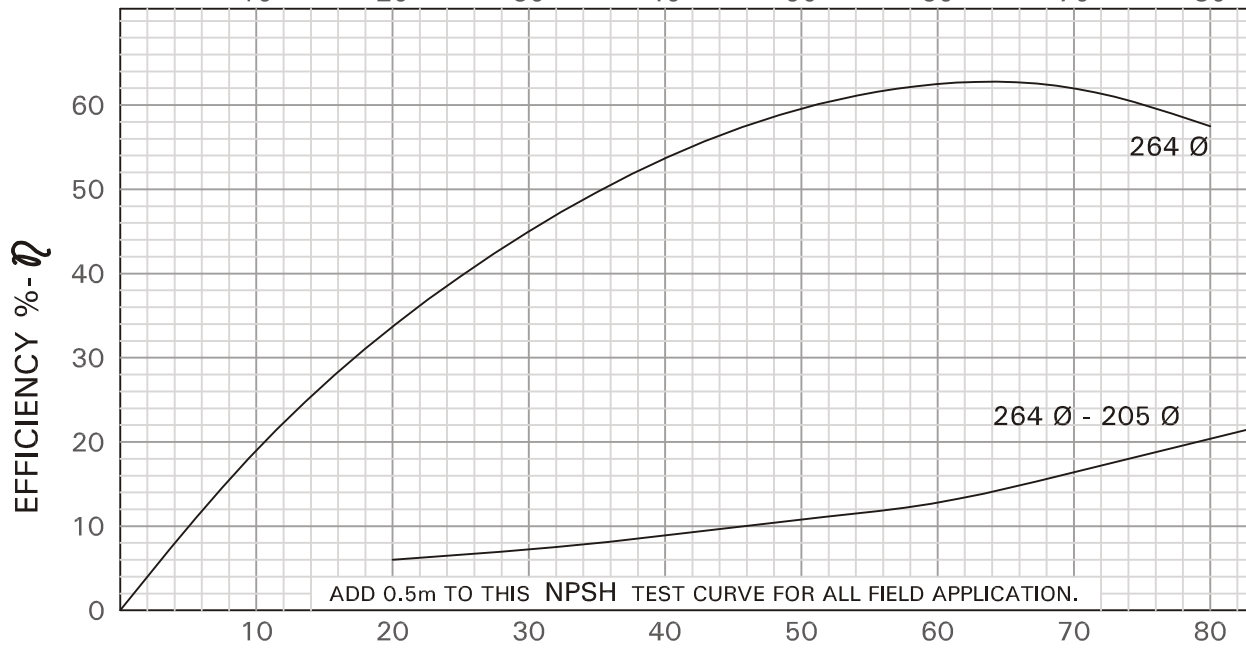
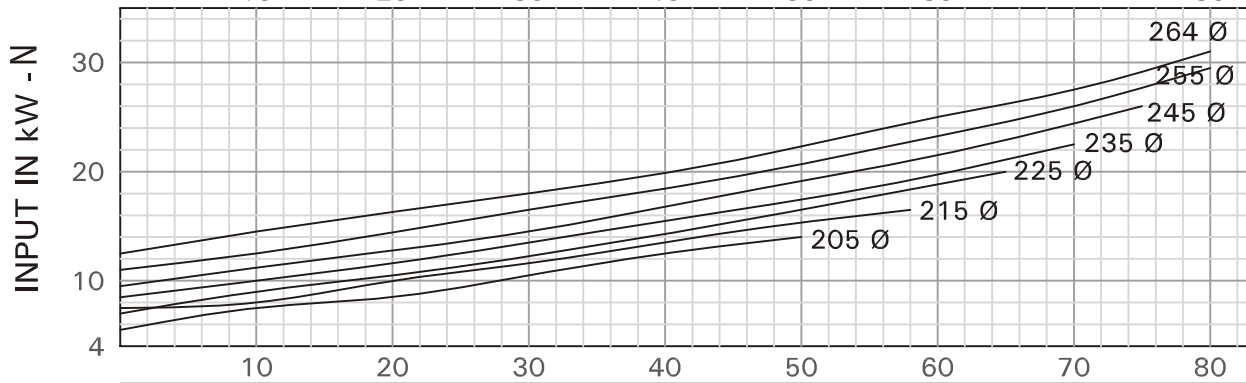
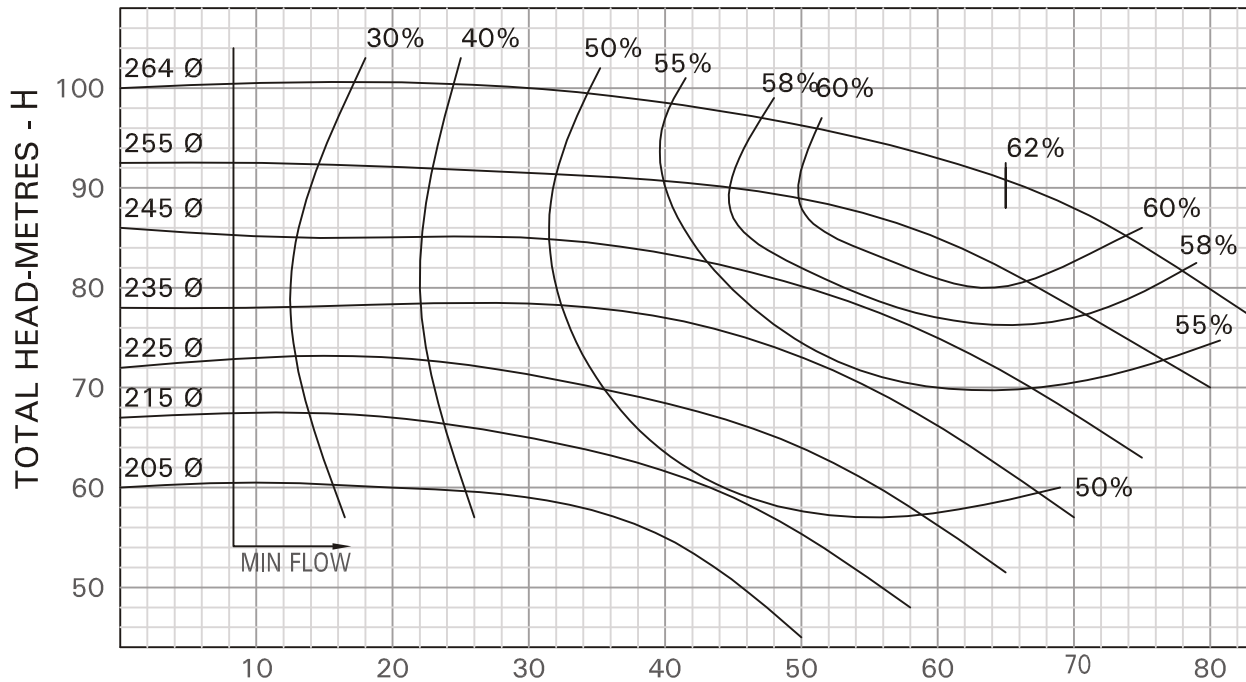

REQUIRED NPSH-M

DISCHARGE Q - m3/hr

RECOMMENDED DELIVERY PIPE SIZE mm	65	85	100	125	
RECOMMENDED SUCTION PIPE SIZE mm	80	100	125	150	

# KIRLOSKAR BROTHERS LIMITED

NO. HD10213A0

## PERFORMANCE CURVE OF PUMP DB 65/13

SUC. 80 mm DEL 65 mm

THIS CURVE RELATES TO LIQUID OF SP.GR. = 1.0

n = 2900 rpm  
(NOMINAL)



Enriching Lives

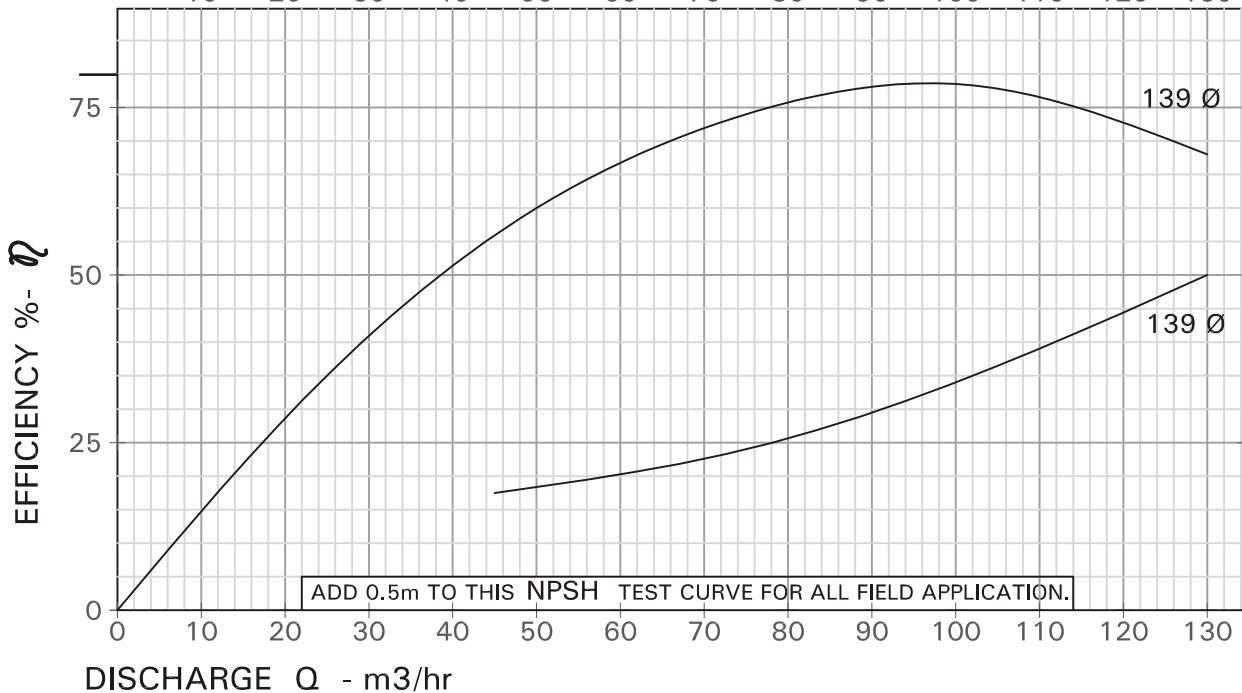
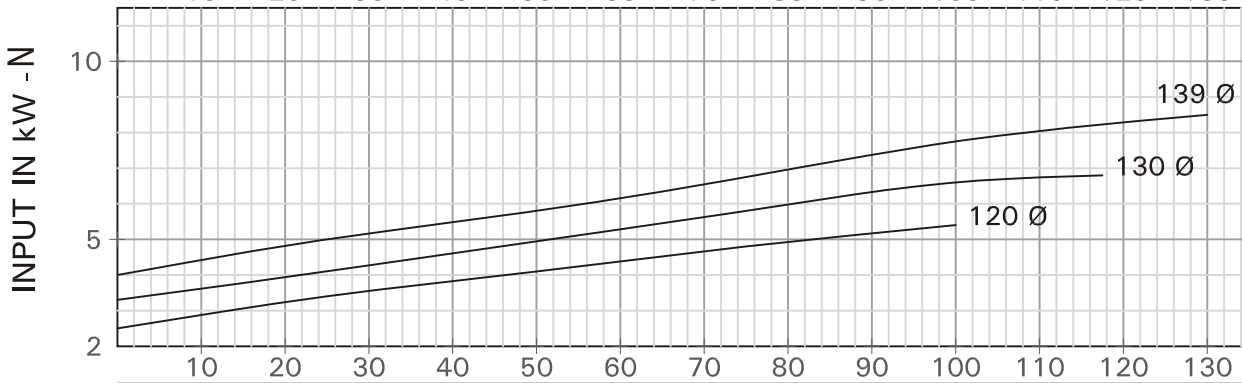
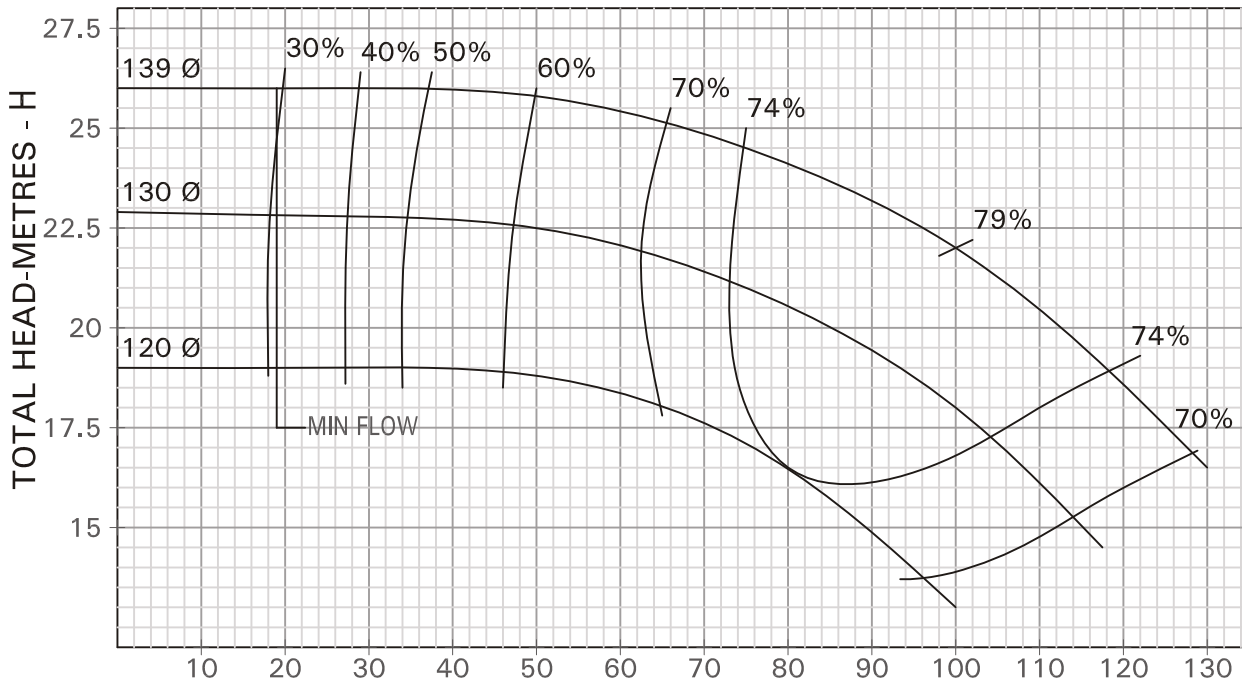

REQUIRED NPSH-M

RECOMMENDED DELIVERY PIPE SIZE mm	100	125	150	
RECOMMENDED SUCTION PIPE SIZE mm	100	125	150	175.

# KIRLOSKAR BROTHERS LIMITED

NO. HD10214AOR

## PERFORMANCE CURVE OF PUMP DB 65/16

SUC. 80 mm DEL 65mm

THIS CURVE RELATES TO LIQUID OF SP.GR. = 1.0

n = 2900 rpm  
(NOMINAL)



Enriching Lives

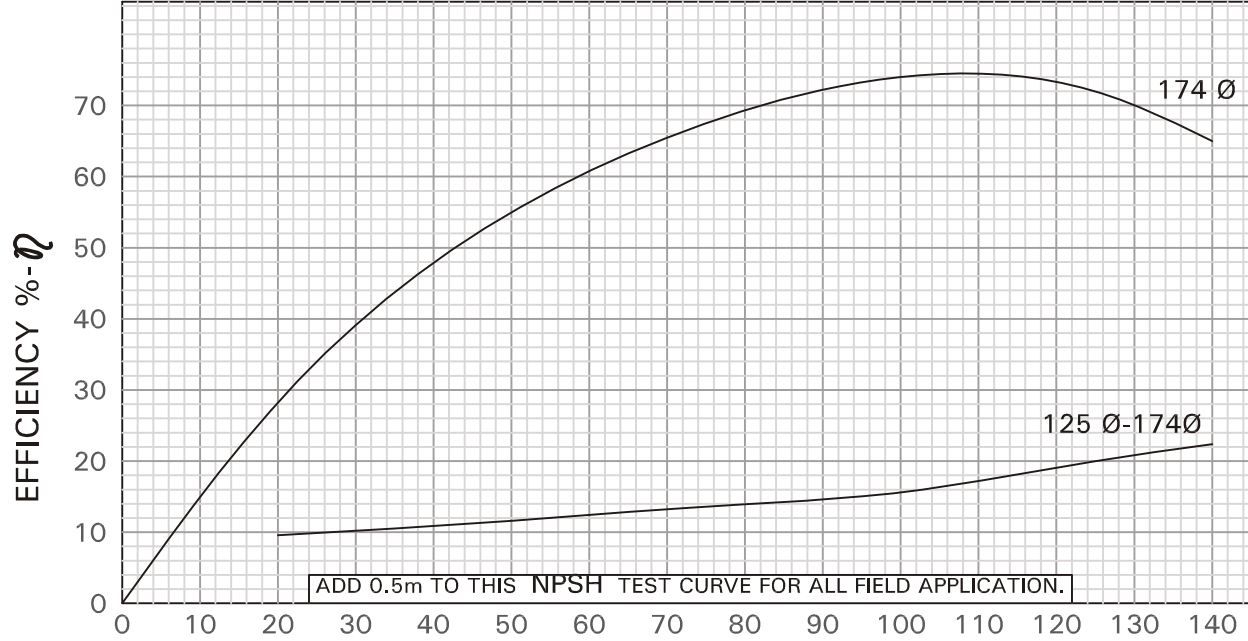
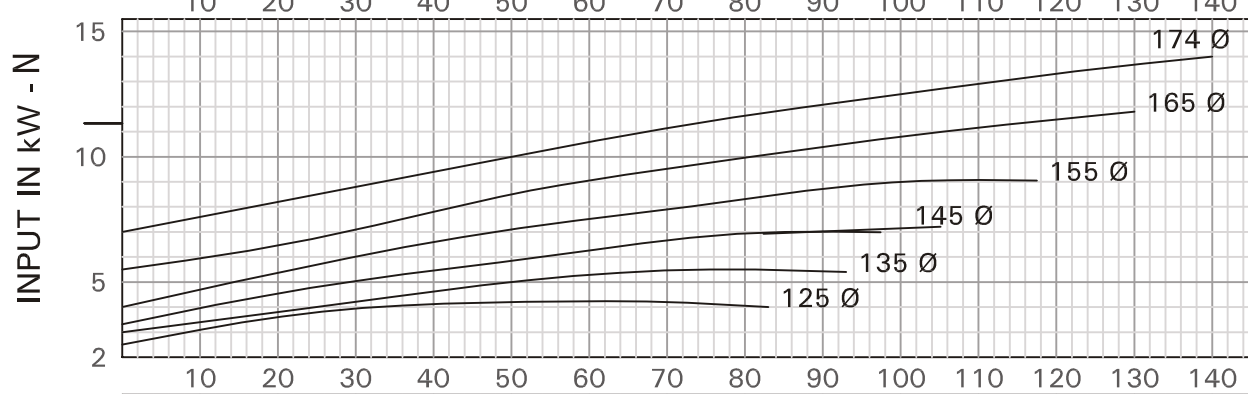
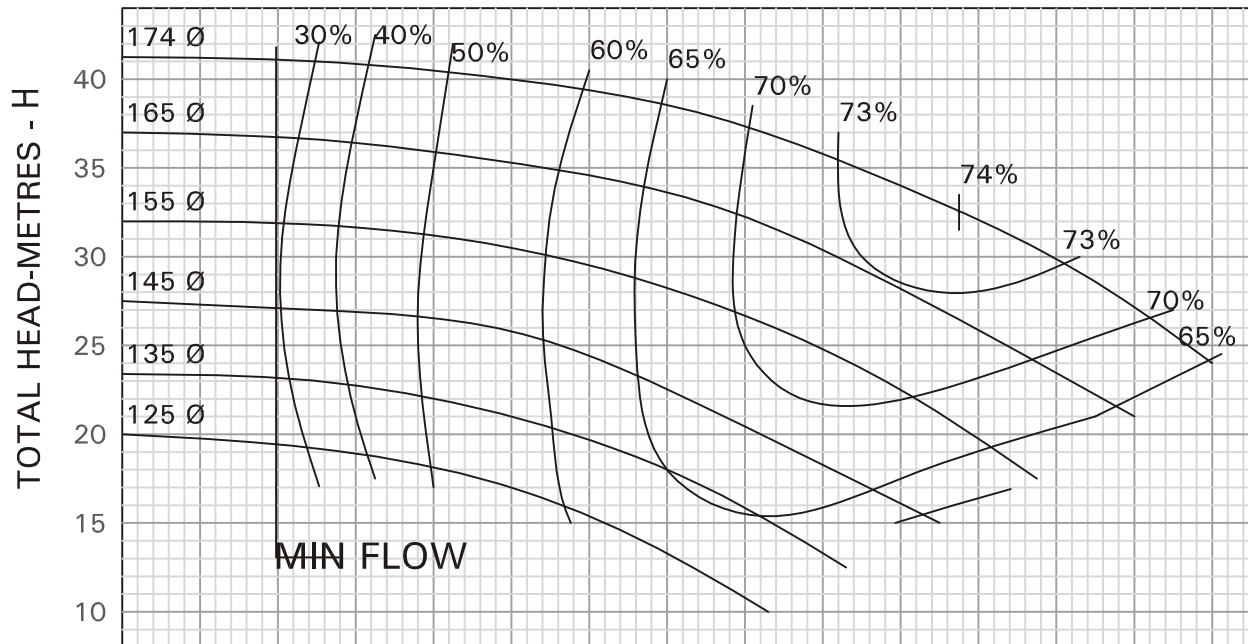

REQUIRED NPSH-M

DISCHARGE Q - m3/hr

RECOMMENDED DELIVERY PIPE SIZE mm	100	125	150	
RECOMMENDED SUCTION PIPE SIZE mm	100	125	150	175

# KIRLOSKAR BROTHERS LIMITED

NO. HD10215A0

## PERFORMANCE CURVE OF PUMP DB 65/20

SUC. 80 mm DEL 65 mm

THIS CURVE RELATES TO LIQUID OF SP.GR. = 1.0

n = 2900<sup>rpm</sup>  
(NOMINAL)



Enriching Lives

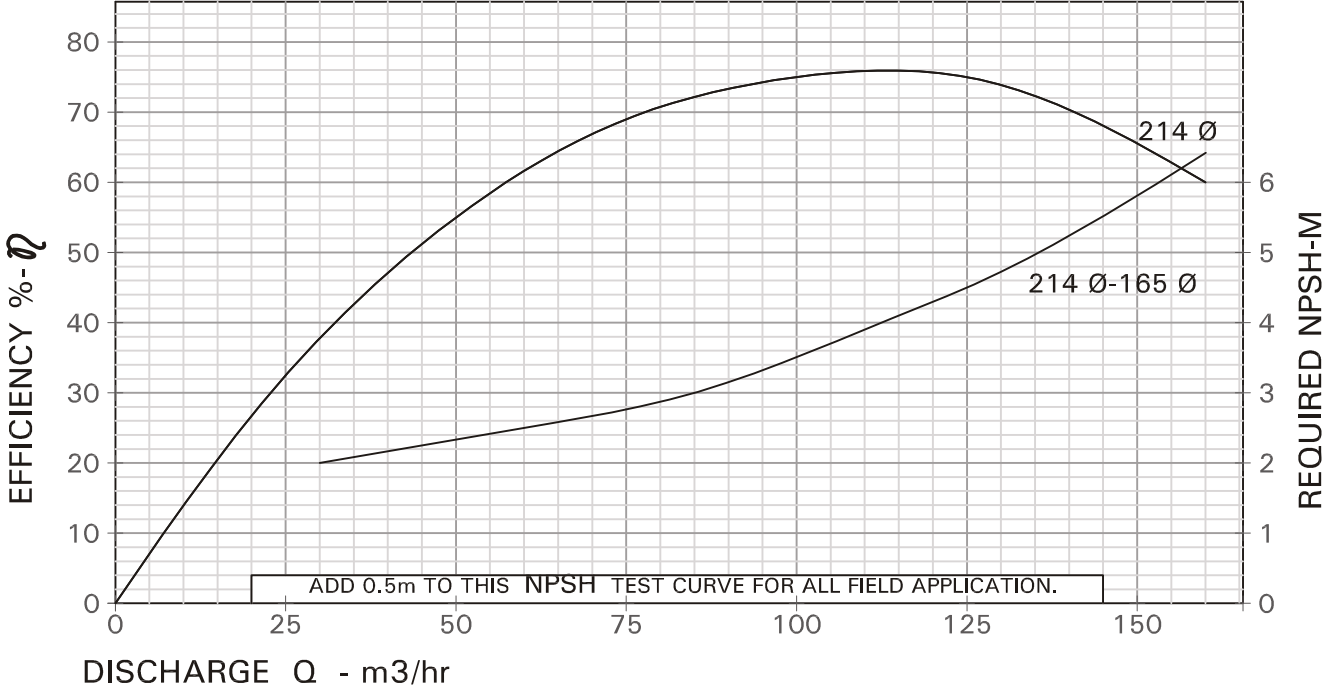
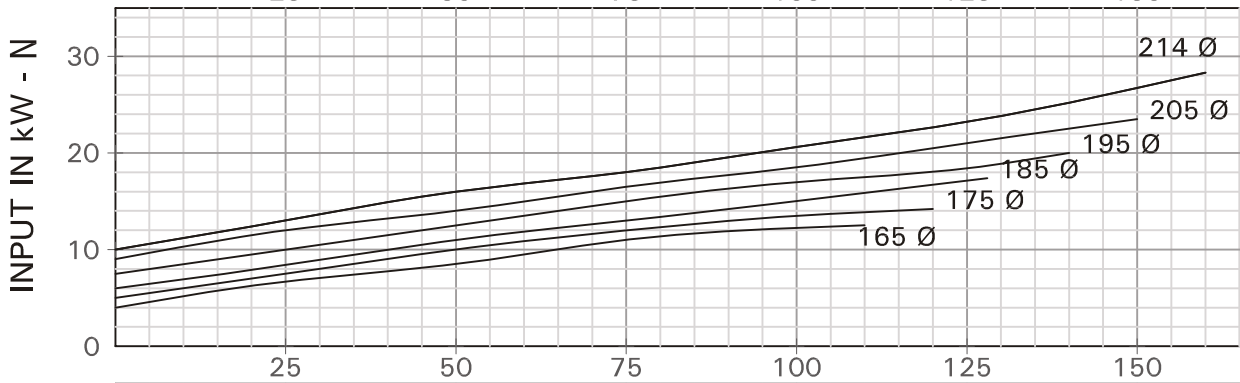
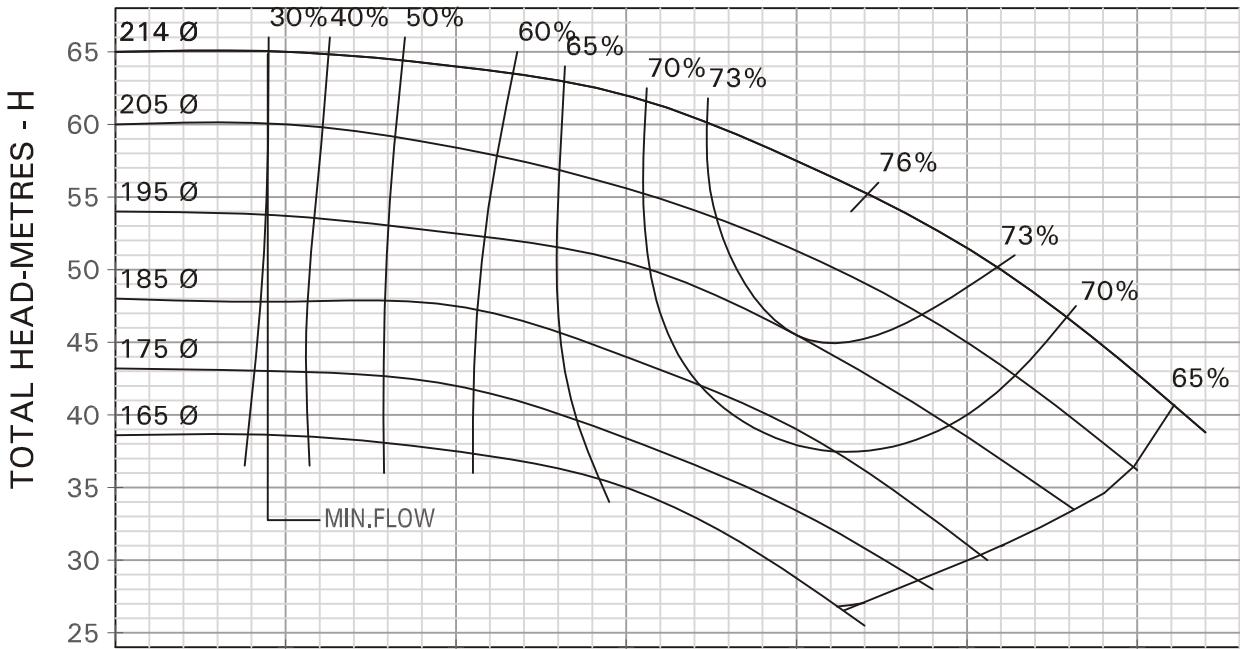

RECOMMENDED DELIVERY PIPE SIZE mm	100	100	100	100	
RECOMMENDED SUCTION PIPE SIZE mm	100	125	150	175	200

# KIRLOSKAR BROTHERS LIMITED

NO. HD10216A0

## PERFORMANCE CURVE OF PUMP DB 65/26

SUC. 80 mm DEL 65mm

THIS CURVE RELATES TO LIQUID OF SP.GR. = 1.0

n = 2900<sup>rpm</sup>  
(NOMINAL)



Enriching Lives

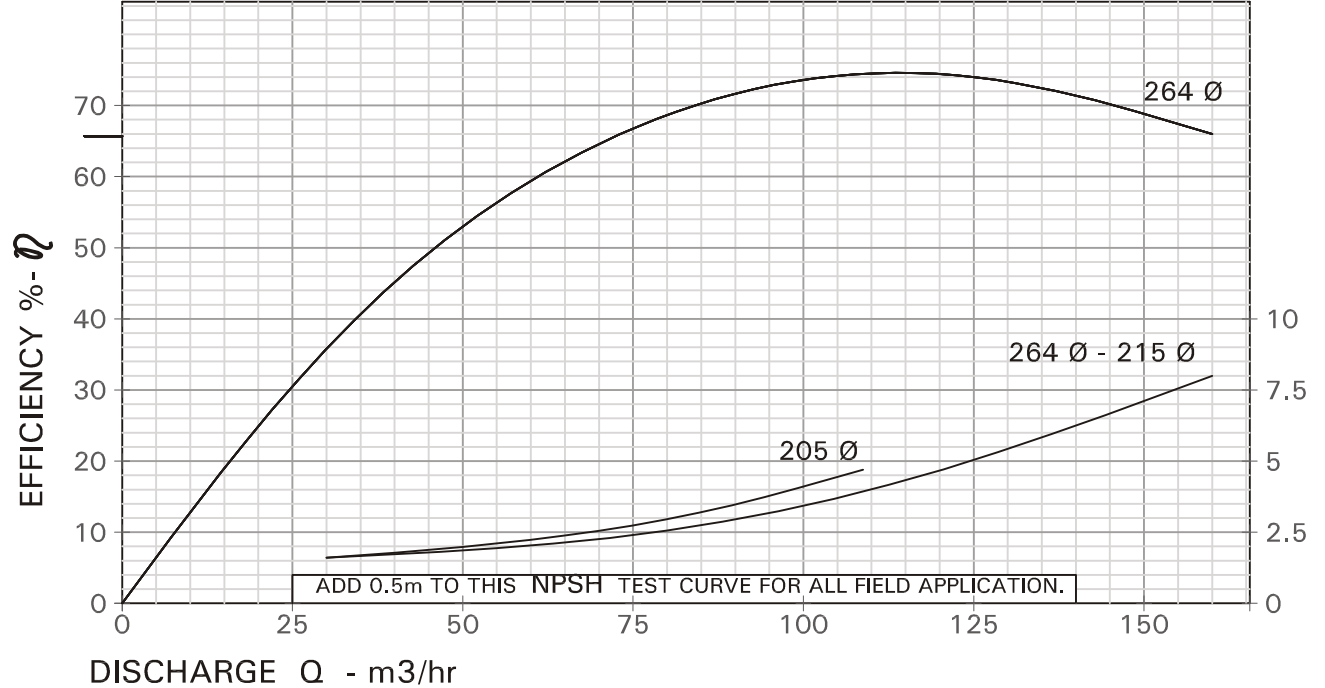
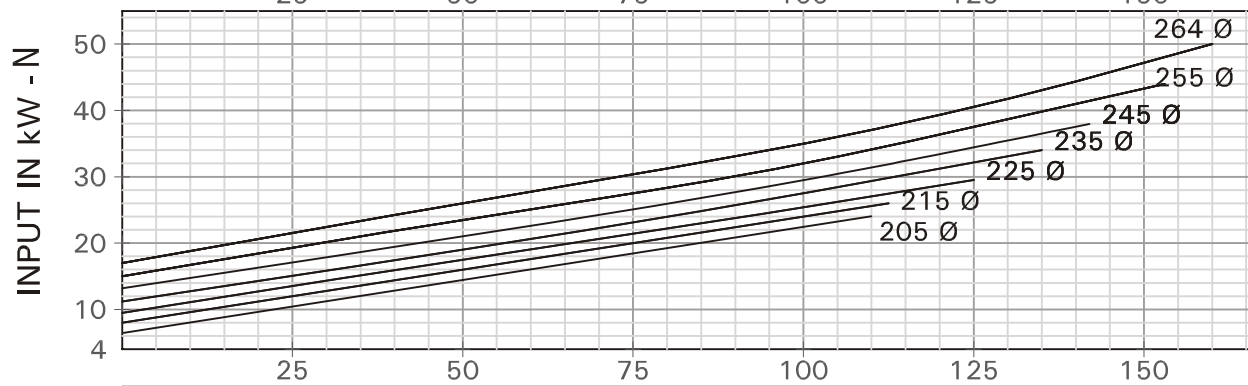
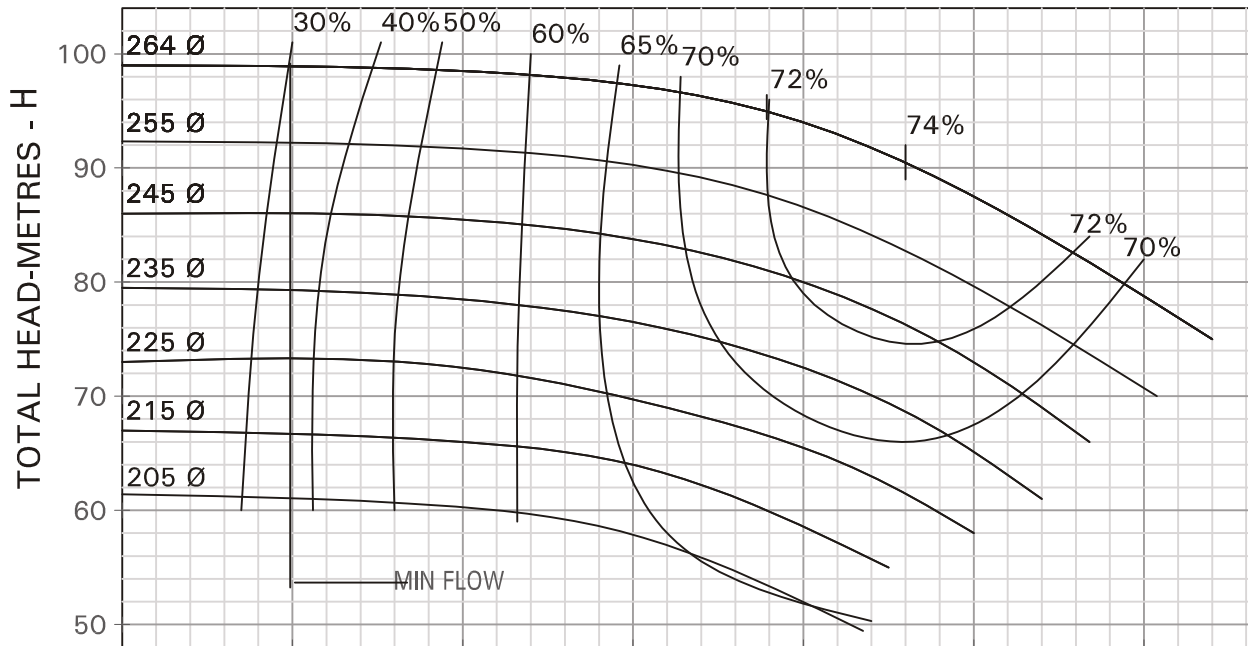

RECOMMENDED DELIVERY PIPE SIZE mm	100	125	150	175	
RECOMMENDED SUCTION PIPE SIZE mm	100	125	150	175	200

# KIRLOSKAR BROTHERS LIMITED

NO. HD10218A0

## PERFORMANCE CURVE OF PUMP DB 80/16

SUC. 100mm DEL 80mm

THIS CURVE RELATES TO LIQUID OF SP.GR. = 1.0

n = 2900<sup>rpm</sup>  
(NOMINAL)



Enriching Lives

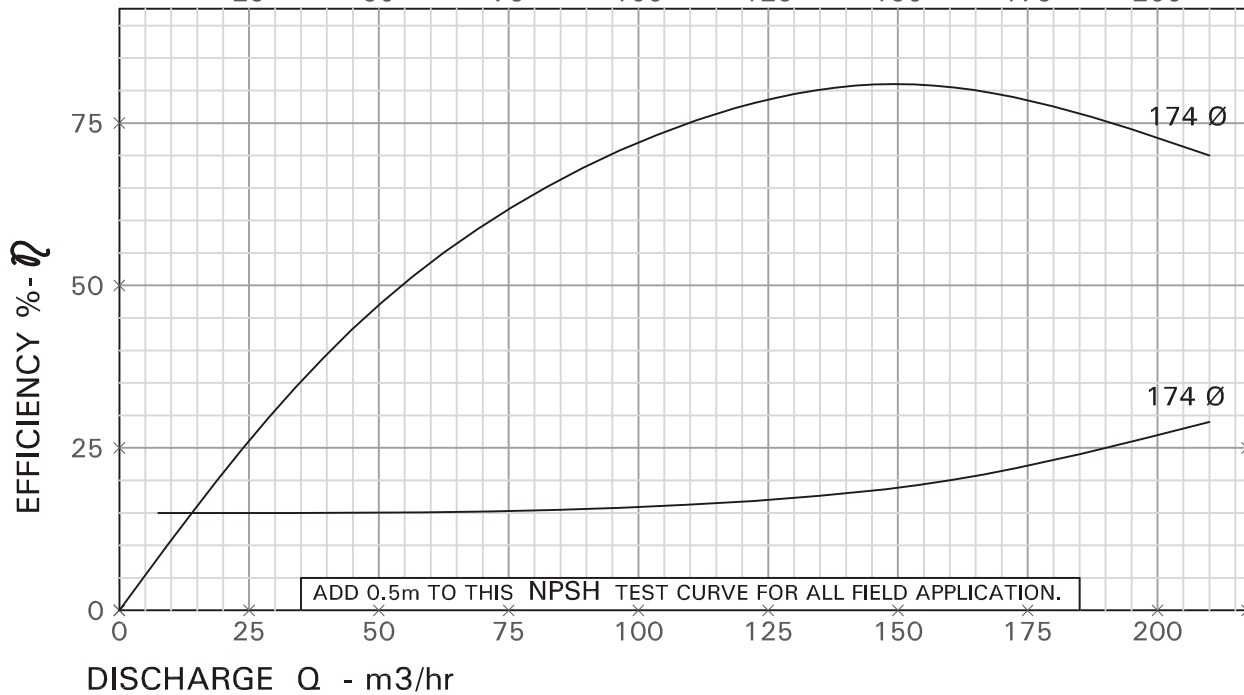
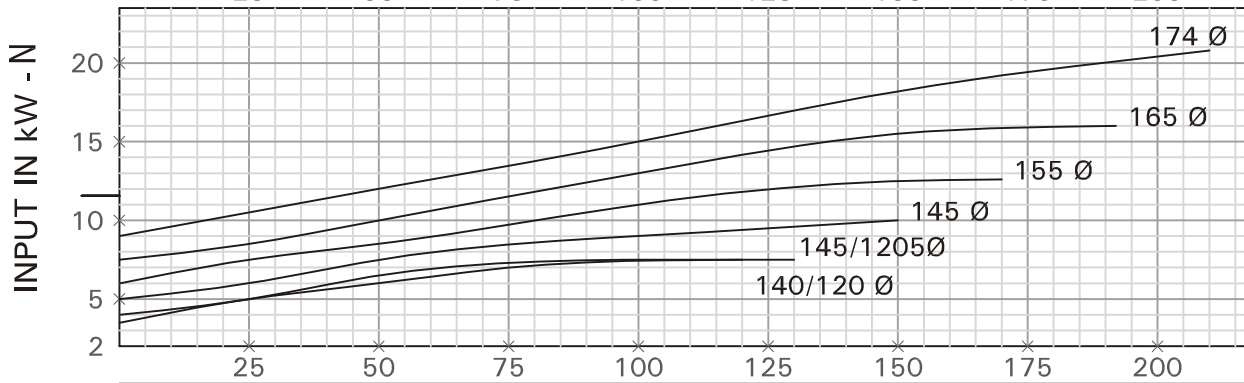
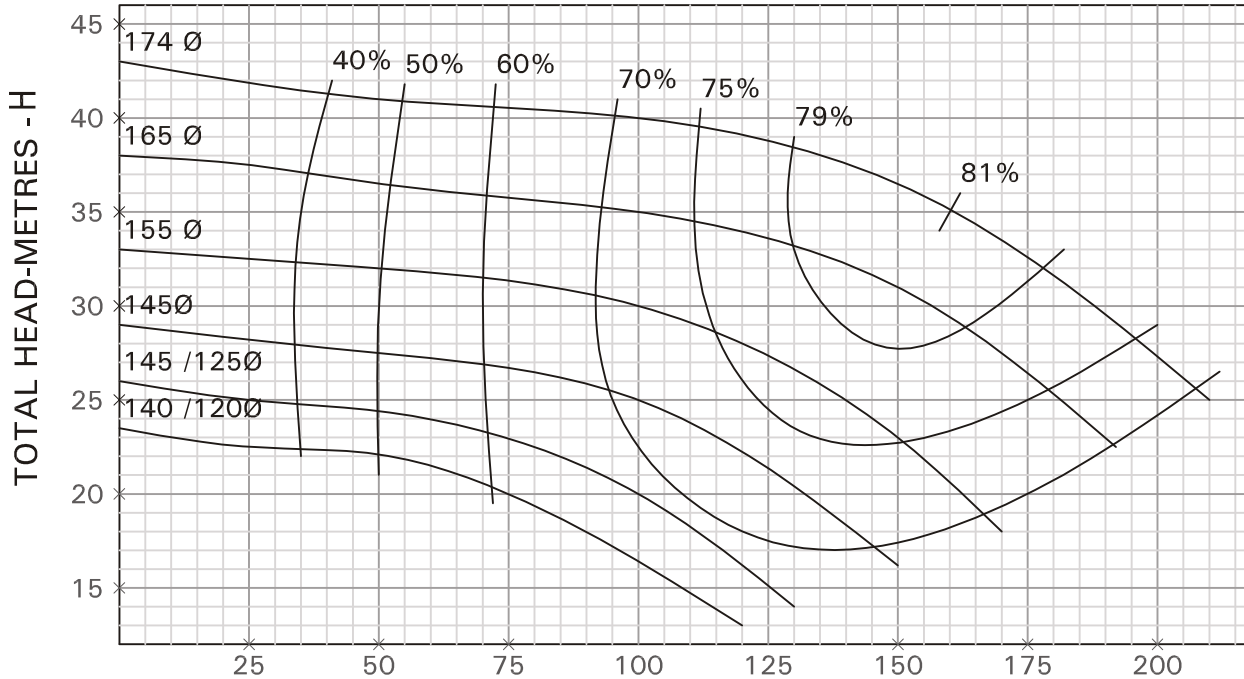

RECOMMENDED DELIVERY PIPE SIZE mm	
RECOMMENDED SUCTION PIPE SIZE mm	

# KIRLOSKAR BROTHERS LIMITED

NO. HD10219A0

## PERFORMANCE CURVE OF PUMP DB 80/20

SUC. 100mm DEL .80 mm

THIS CURVE RELATES TO LIQUID OF SP.GR. = 1.0

n = 2900 rpm  
(NOMINAL)



Enriching Lives

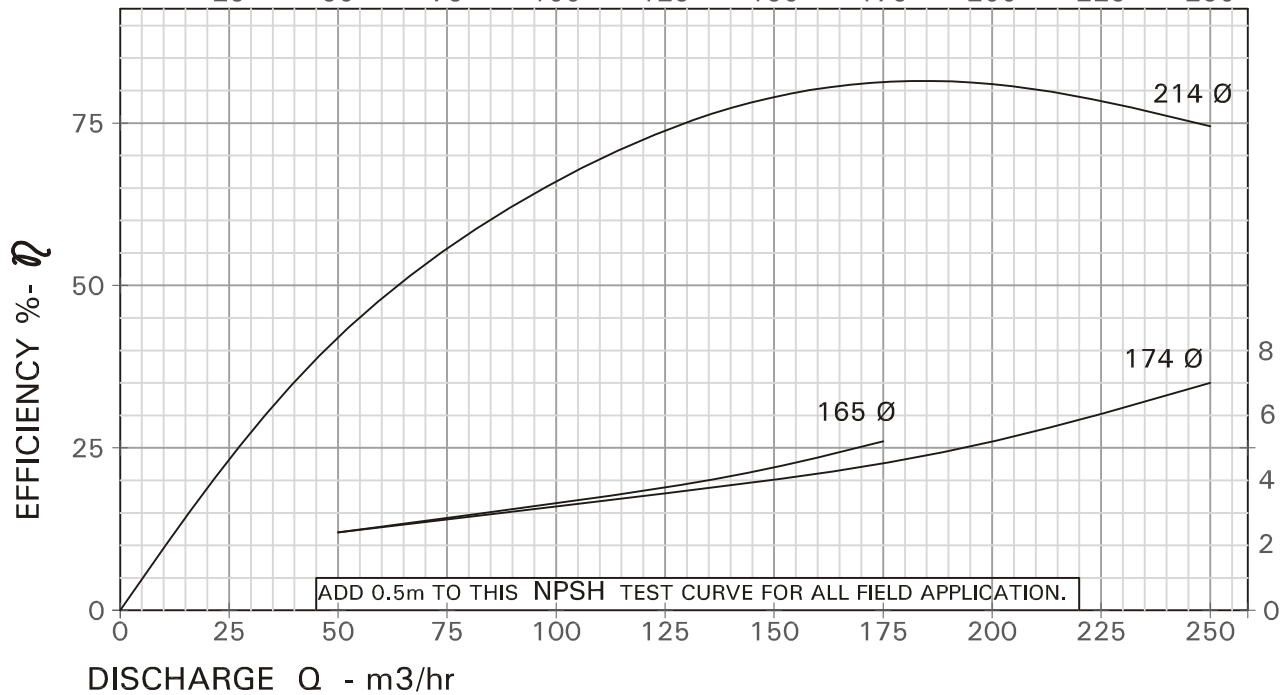
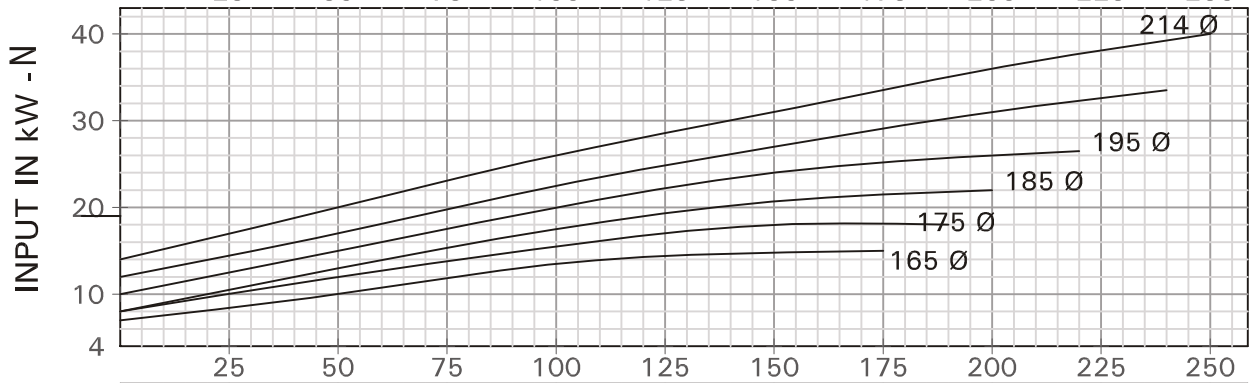
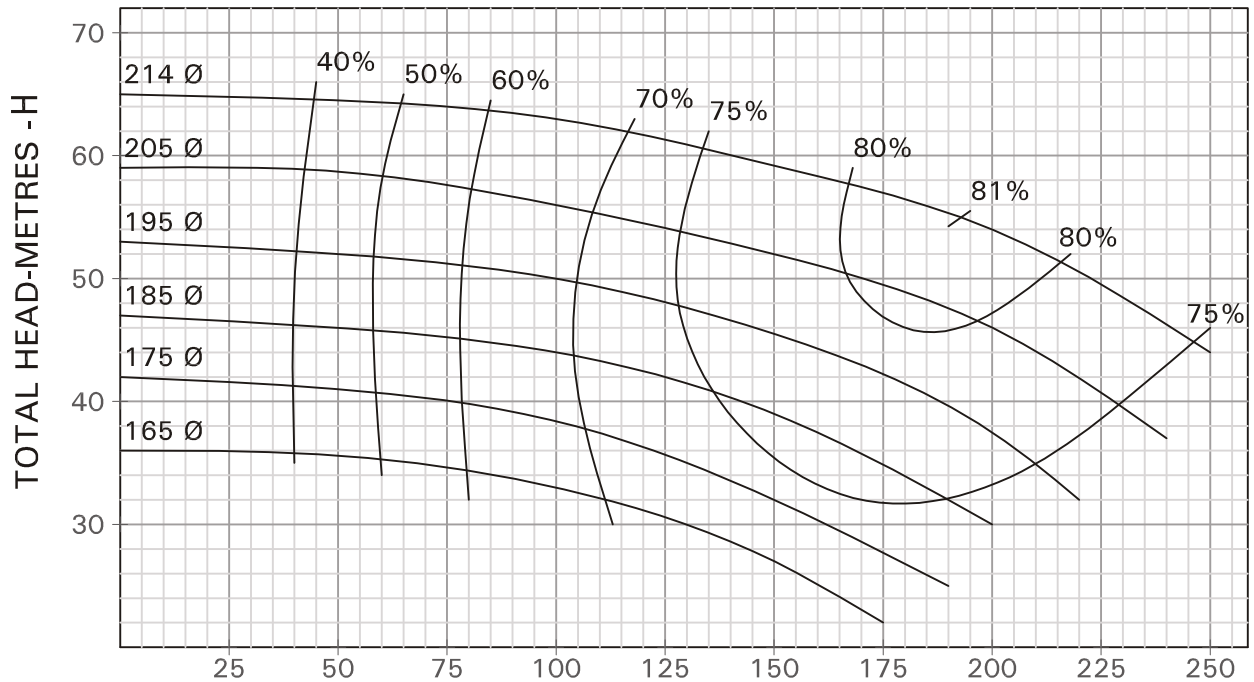

REQUIRED NPSH-M

DISCHARGE Q - m3/hr

RECOMMENDED DELIVERY PIPE SIZE mm	125	150	175	200	
RECOMMENDED SUCTION PIPE SIZE mm	150		175	200	225

# KIRLOSKAR BROTHERS LIMITED

NO. HD10220A0R

## PERFORMANCE CURVE OF PUMP DB 80/26

SUC. 100 mm DEL 80 mm

THIS CURVE RELATES TO LIQUID OF SP.GR. = 1.0

n = 2900<sup>rpm</sup>  
(NOMINAL)



Enriching Lives

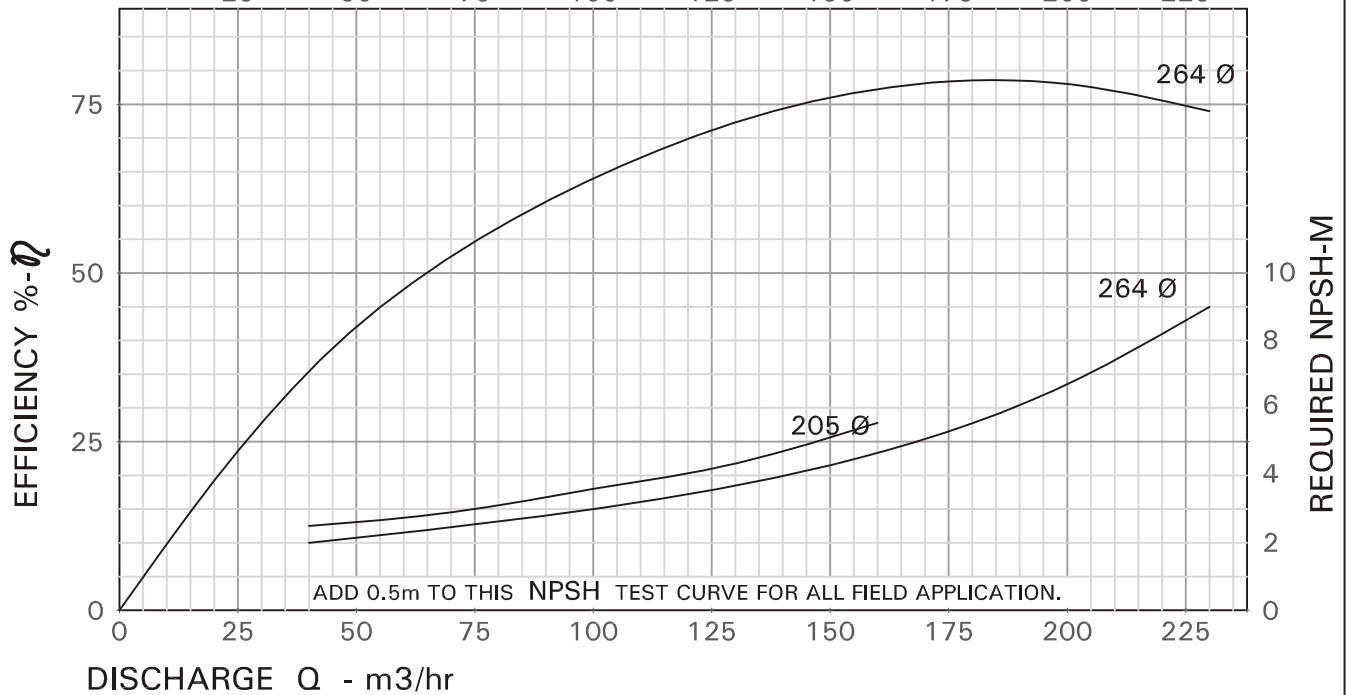
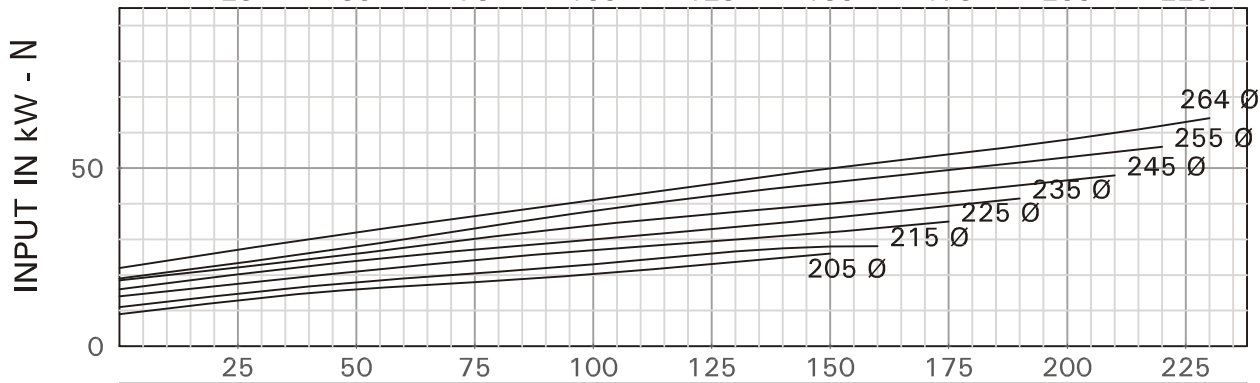
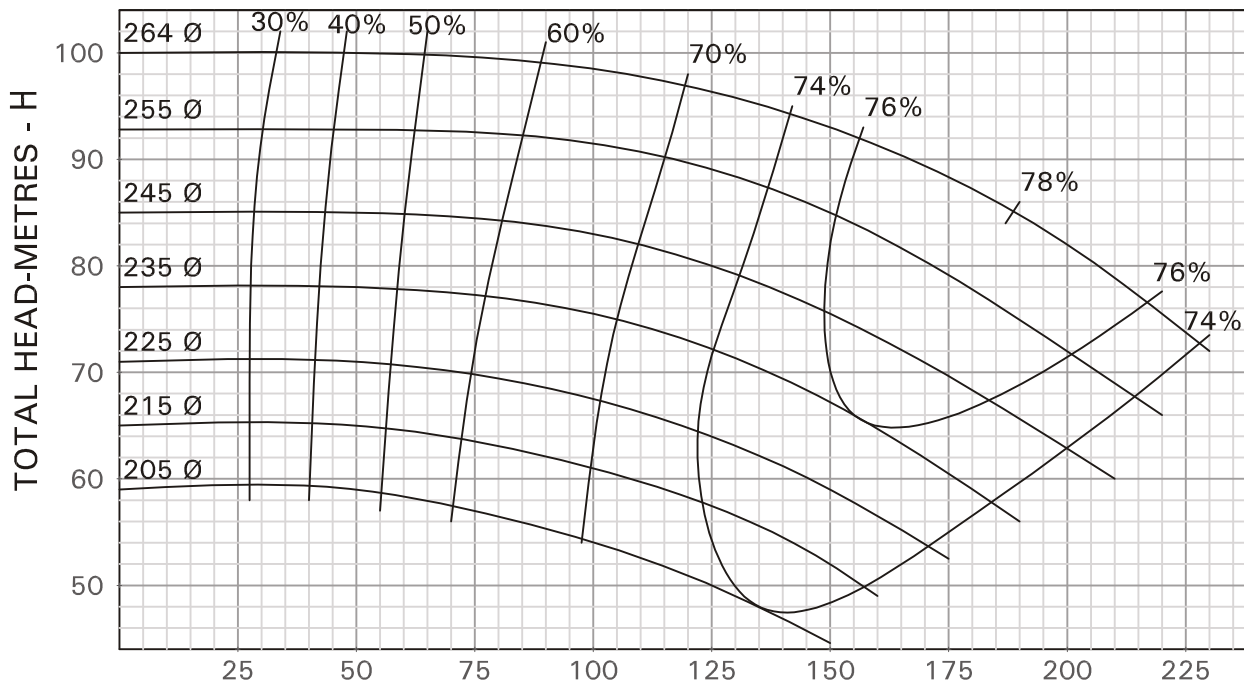

RECOMMENDED DELIVERY PIPE SIZE mm	125	150	175	
RECOMMENDED SUCTION PIPE SIZE mm	125	150	175	200

# KIRLOSKAR BROTHERS LIMITED

NO. HD10222A0

## PERFORMANCE CURVE OF PUMP DB 100/20

SUC. 125 mm DEL 100 mm

THIS CURVE RELATES TO LIQUID OF SP.GR. = 1.0

n = 2900<sup>rpm</sup>  
(NOMINAL)



Enriching Lives

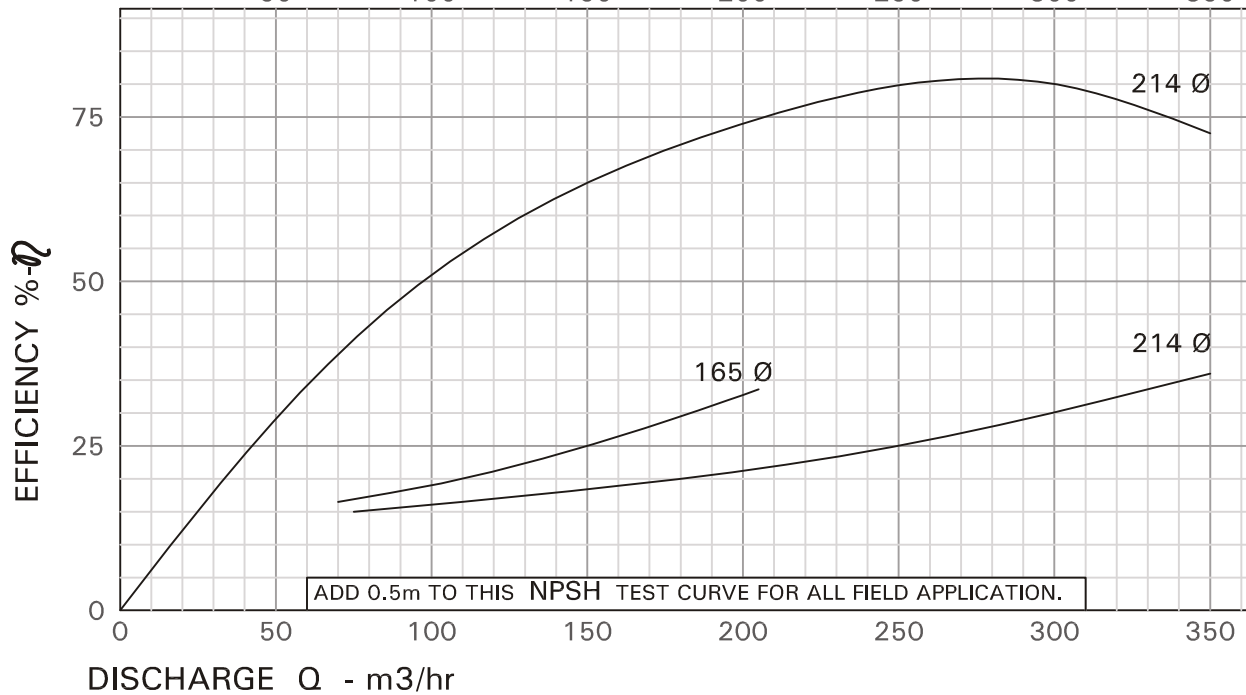
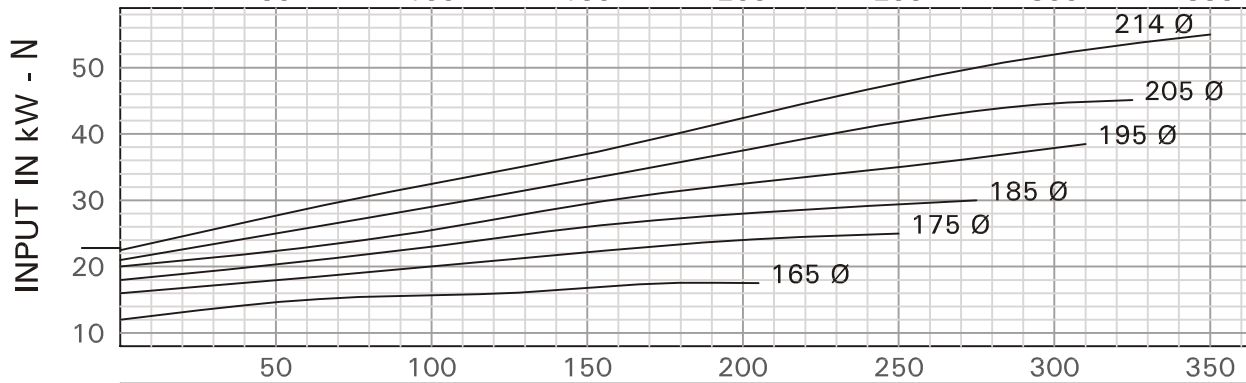
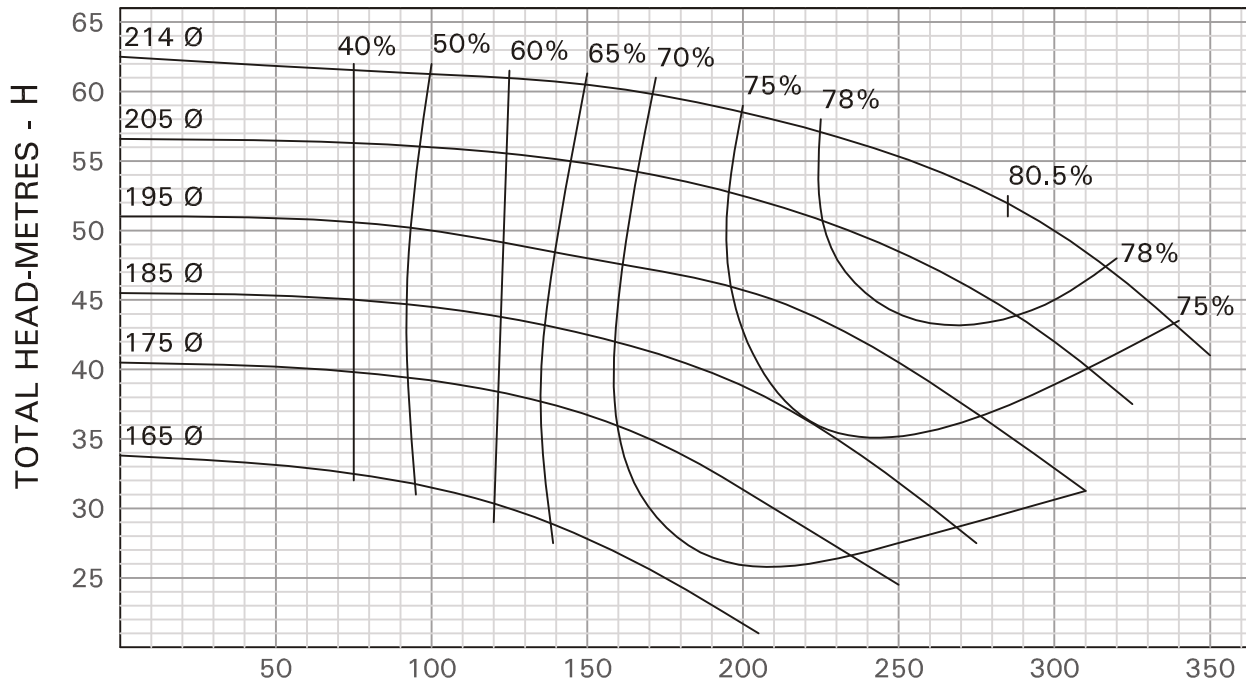

REQUIRED NPSH-M

RECOMMENDED DELIVERY PIPE SIZE mm	125	150	175	200	225	
RECOMMENDED SUCTION PIPE SIZE mm	150	175	200	225	250	

# KIRLOSKAR BROTHERS LIMITED

NO. HD10223A0

## PERFORMANCE CURVE OF PUMP DB 100/26

SUC. 125 mm DEL 100 mm

THIS CURVE RELATES TO LIQUID OF SP.GR. = 1.0

n = 2900 rpm  
(NOMINAL)



Enriching Lives

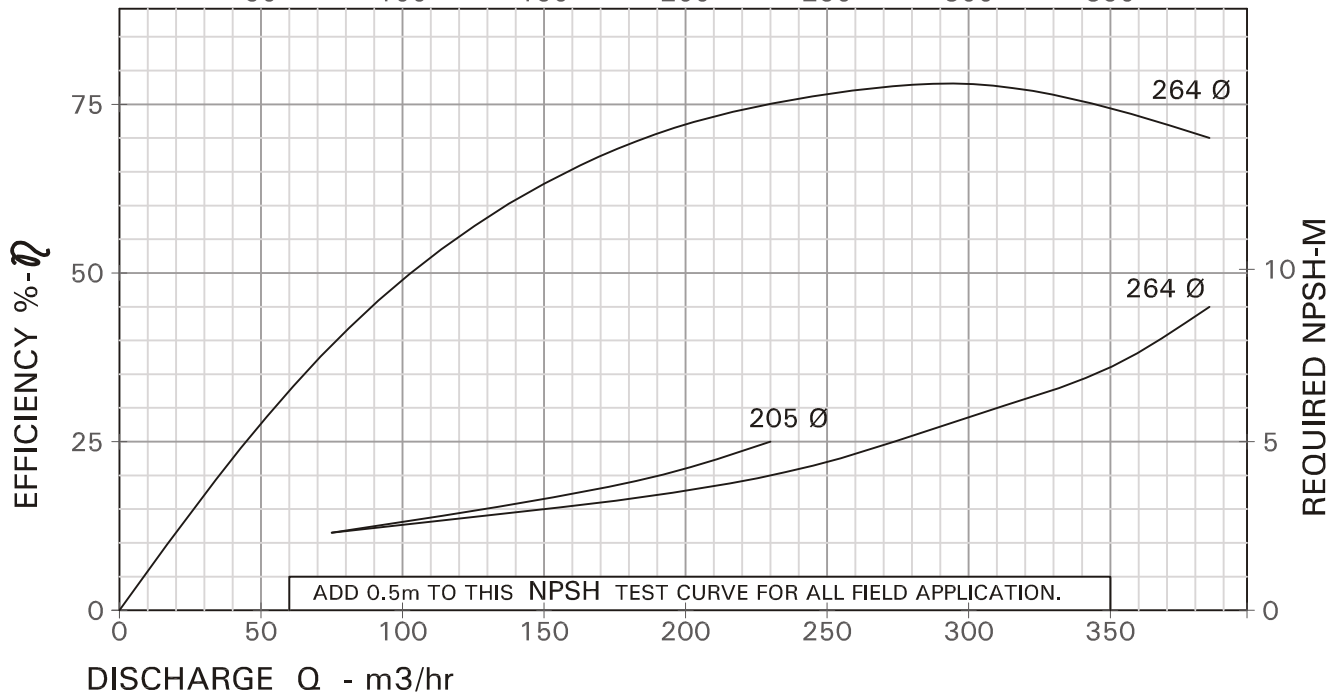
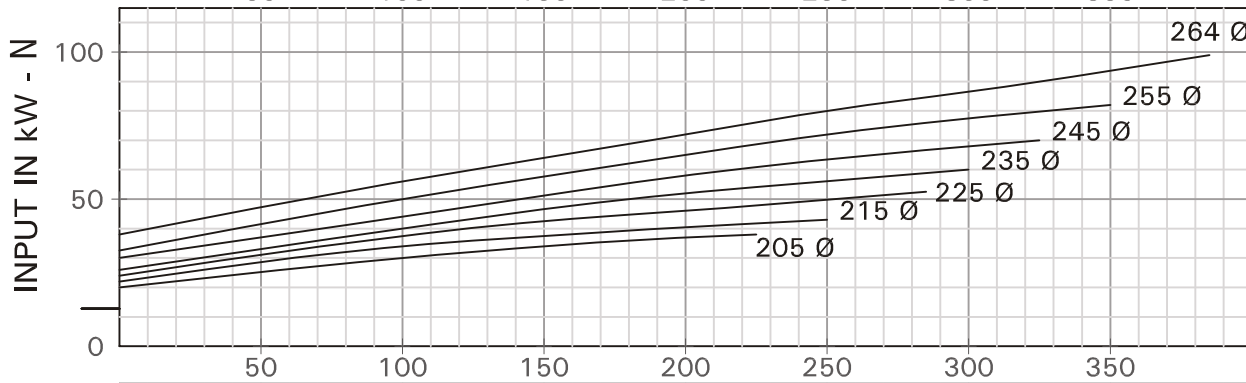
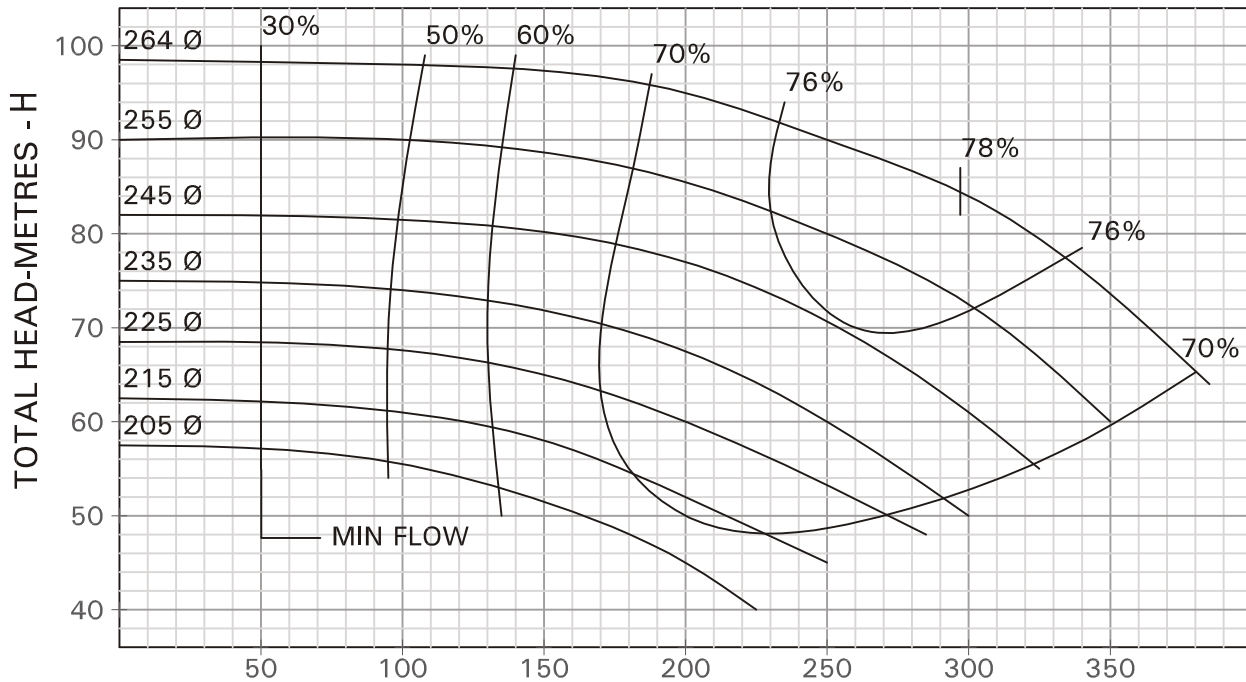

RECOMMENDED DELIVERY PIPE SIZE mm	150	175	200	225	250	
RECOMMENDED SUCTION PIPE SIZE mm	150	175	200	225	250	300



## OUR GLOBAL PRESENCE



As we are constantly endeavouring to improve the performance of our products/ equipment, we reserve the right to make alterations from time to time and as such our products/ equipment may differ from that detailed in this publication. For latest information you may get in touch with our Regional Sales Offices.



Enriching Lives

### KIRLOSKAR BROTHERS LIMITED

#### CORPORATE OFFICE :

"YAMUNA", Survey No. 98 (3/7), Baner,  
Pune - 411045, INDIA  
Tel.: +91 20 27214444 Fax: +91 20 27211117  
email: [kblin@kbl.co.in](mailto:kblin@kbl.co.in) website: [www.kbl.co.in](http://www.kbl.co.in)

#### WORKS :

Kirloskarvadi 416308 Dist. Sangli  
Maharashtra, INDIA  
Tel.: +91 2346 222301 to 222305  
Fax: +91 2346 222311



KIRLOSKAR BROTHERS LIMITED

**EUROPE OFFICE** : Kirloskar Brothers Europe BV Rooswijkweg 7-9, 1951 MH Velsen-Noord, The Netherlands. Tel : +31 (0) 251 270000 Fax : +31 (0) 251 272415  
email: [info@kirloskar.eu](mailto:info@kirloskar.eu), website: [www.kirloskar.eu](http://www.kirloskar.eu)