

# **PUMP HAND BOOK**

## **DATA FOR**

### **KPD & KPDQF PUMP**

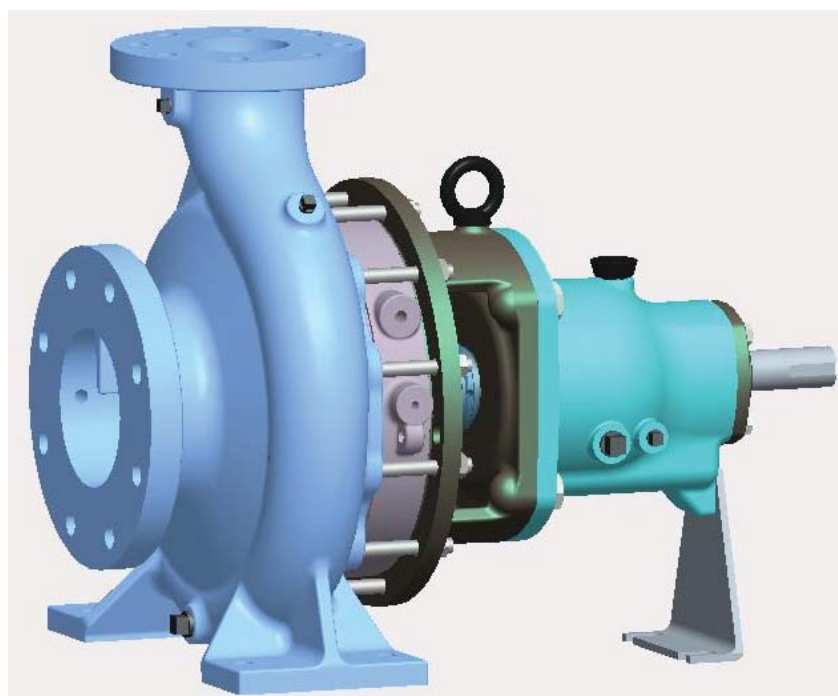

**A- Series –KPD**

**B- 1. Application:** KPD pump is mainly used in process industries like petrochemicals, nuclear, refinery, fertilizer, paper, sugar etc. and power plants. The pump can handle corrosive acids, alkalies, salt solutions, caustics, hydro-carbons, oils, Thermic fluids, liquefied gases, condensates, viscous liquids etc.

**2. Limitations:**

**C- Applicable Standards:**

Design Confirming to DIN 24256(DIN EN 22858) & ISO 2858

**D- Models:**

Following models in KPD/KPDQF series are available.

UNIT4	UNIT5	UNIT 7	UNIT 9	UNIT 11	UNIT 11A	UNIT 11B	UNIT 13
20/13*	25/16*	25/26A#	65/32	125/26#	125/43#	150/43#	200/38M#
20/16*	25/20*	32/26	80/32				200/46#
20/20*	32/13	40/26	80/40				150/52#
	32/16	40/32	80/40N				
	32/16A#	50/26	100/26				
	32/20	50/32	100/32				
	32/20A#	65/16	100/40				
	40/13	65/20	125/26				
	40/16	65/26	125/32				
	40/20	65/26N	125/40				
	40/20A#	80/16	125/40N				
	50/13	80/20	150/32				
	50/16	80/26	150/32N				
	50/16A#	100/20	150/40#				
	50/20		65/43#				
	65/13						

**NOTES:**

1. \* Marked pumps are supplied with semi-open type impeller as a standard supply.
2. # Marked pumps are supplied with enclosed type impeller only.
3. Pump models with suffix "N" are modified for improvement in rising nature performance towards shut-off.
4. Pump models with suffix "A" are with improved efficiency than standard model.



### 3. KPDQF pumps at 1450 rpm

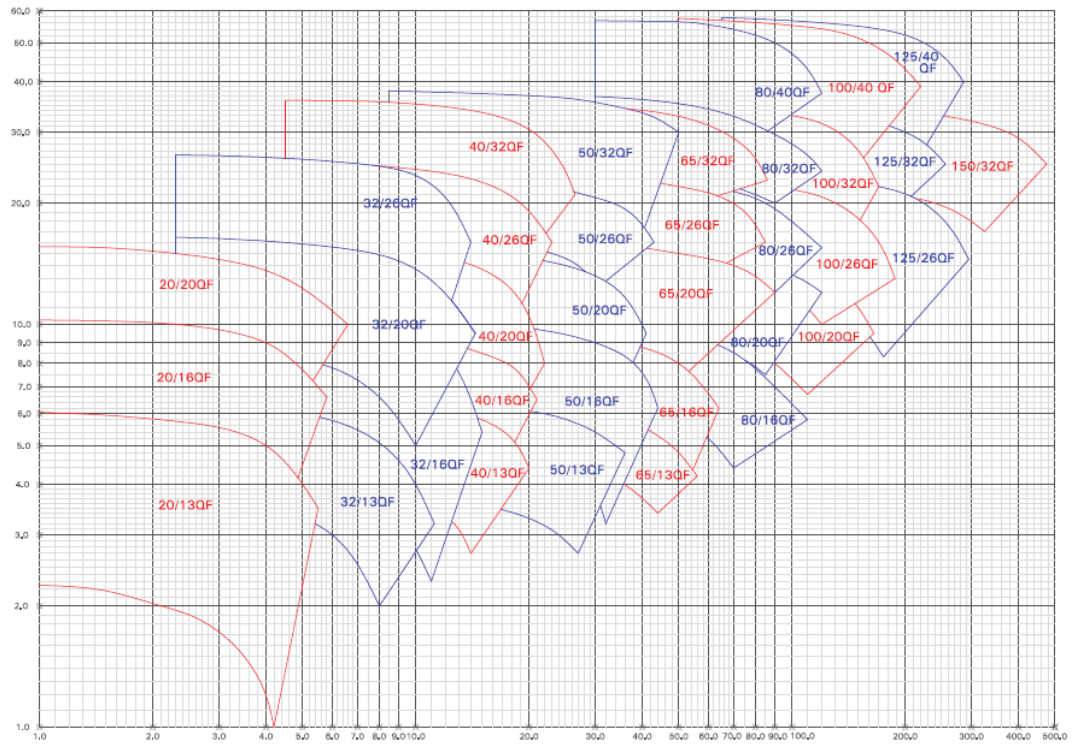

### 4. KPDQF pumps at 2900 rpm

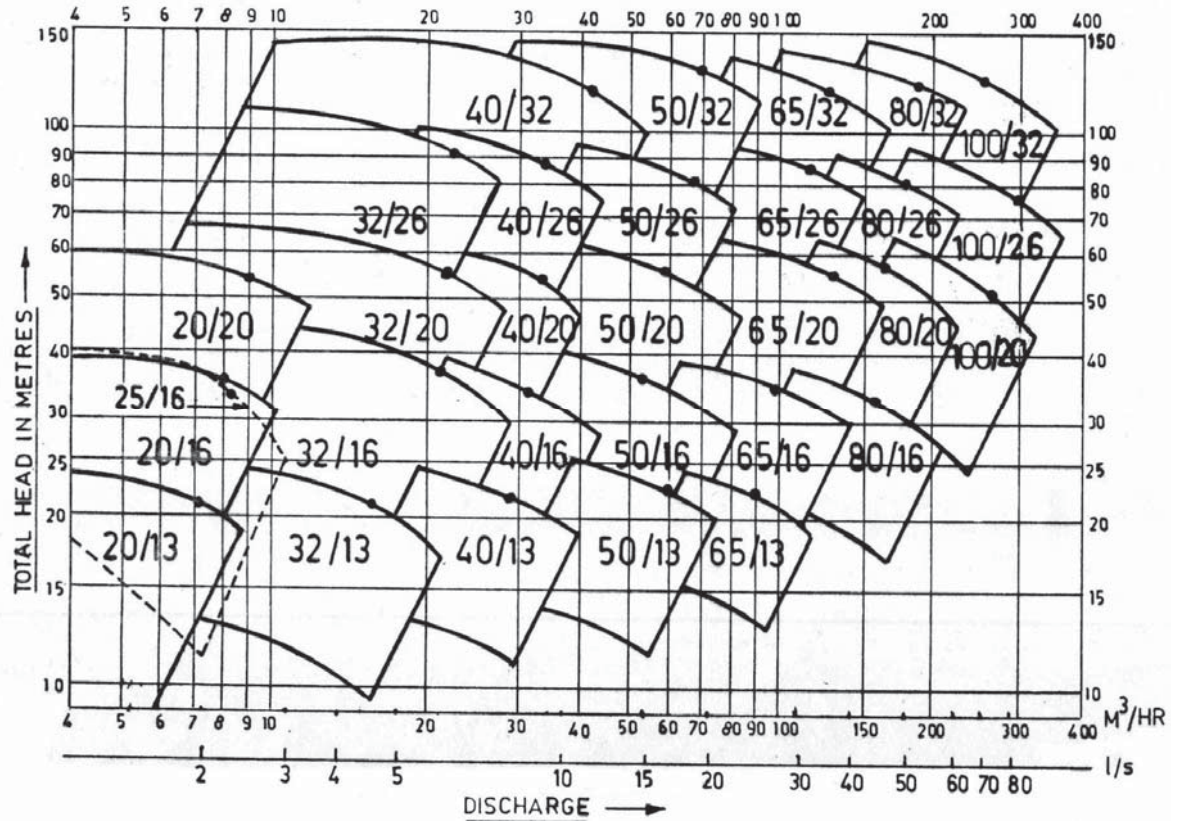

## F- ISO Efficiency curves:

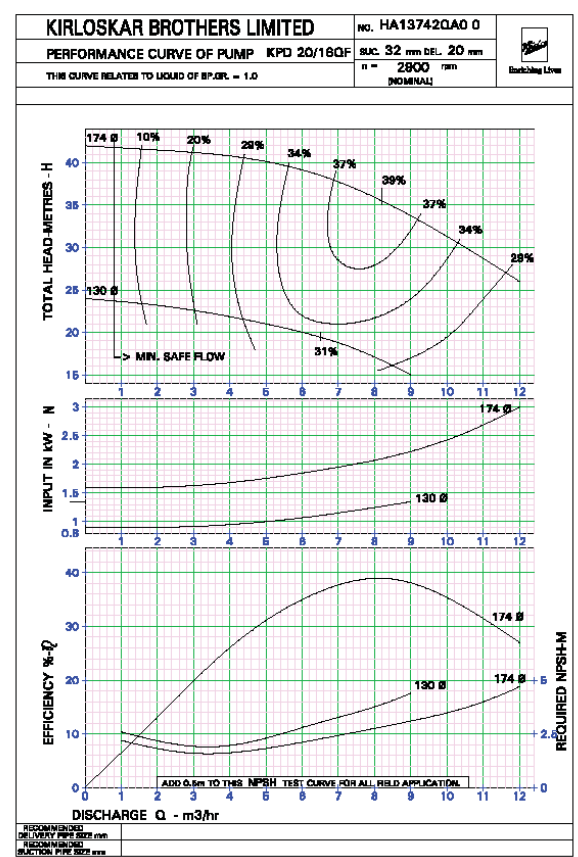
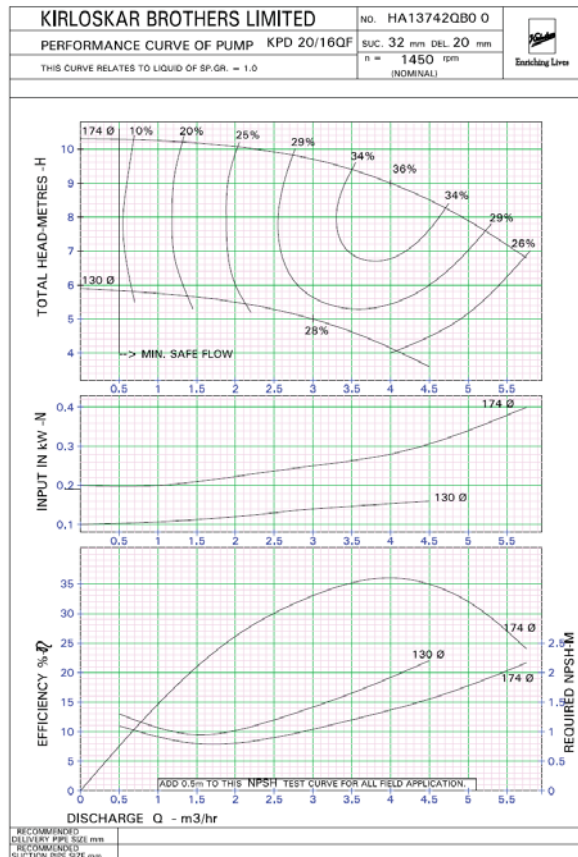
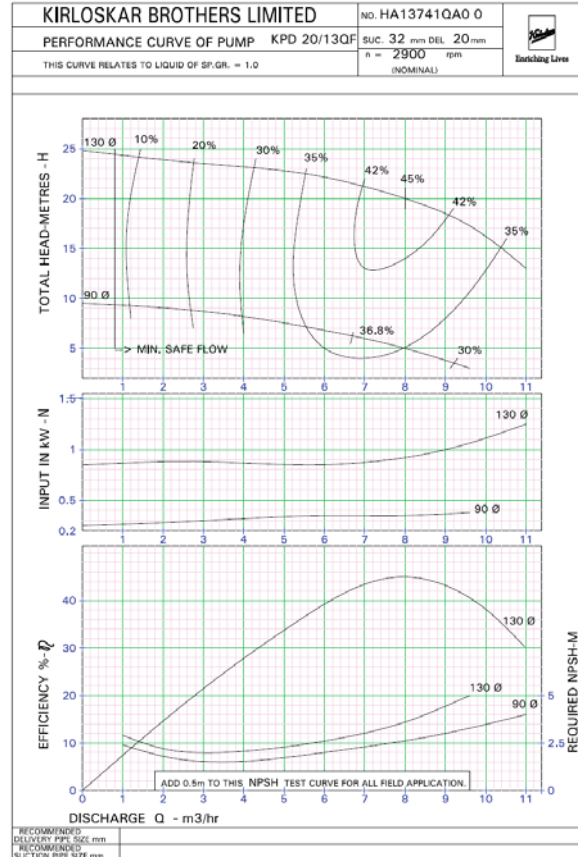
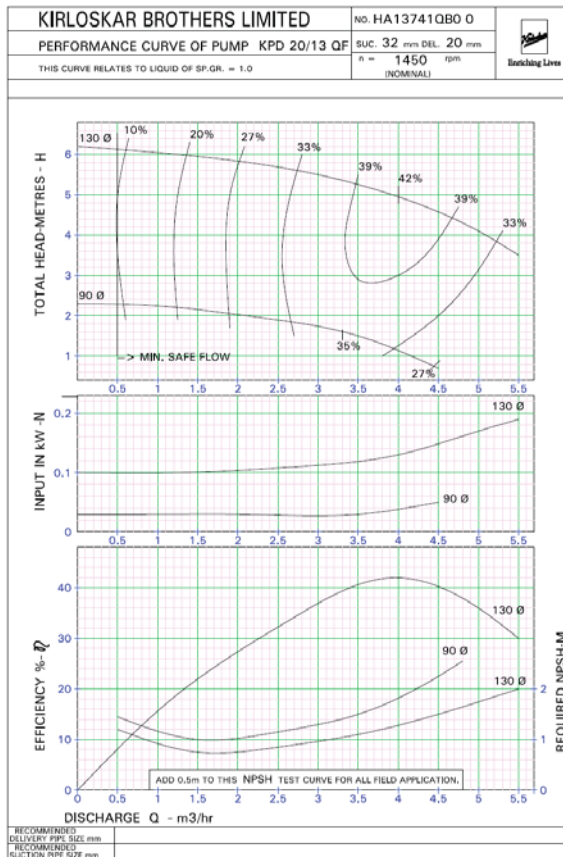

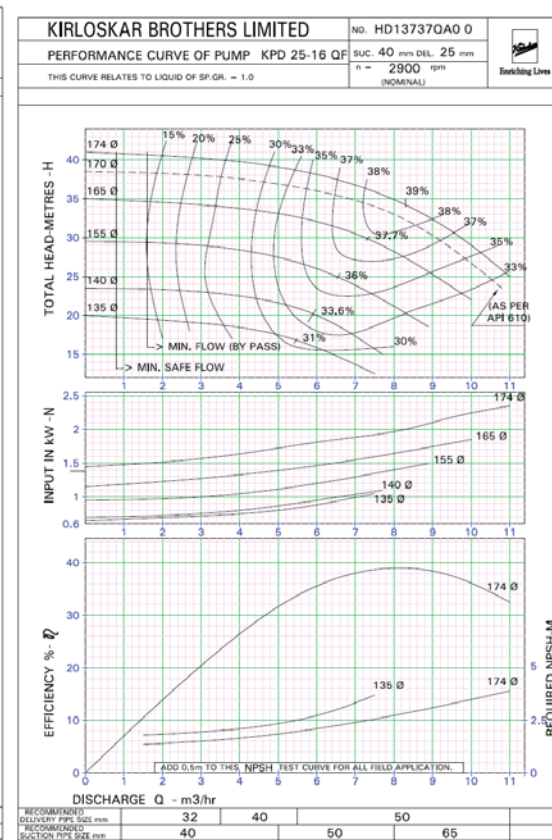
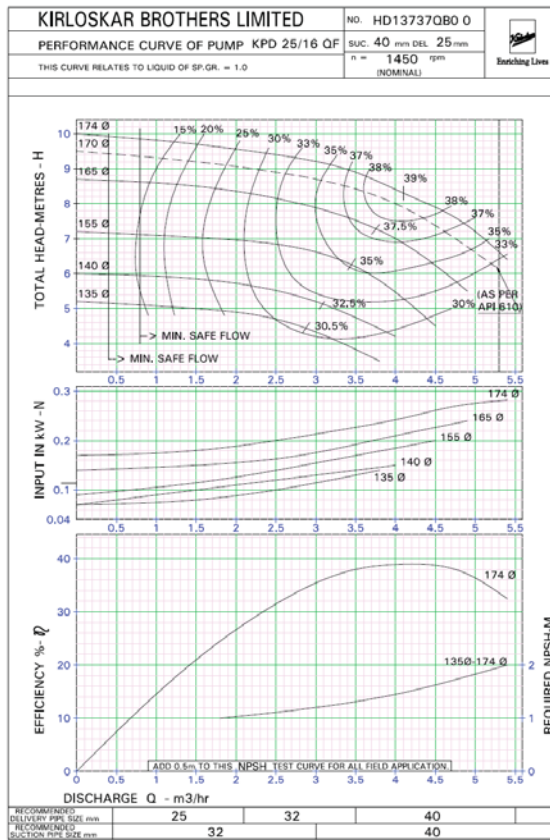
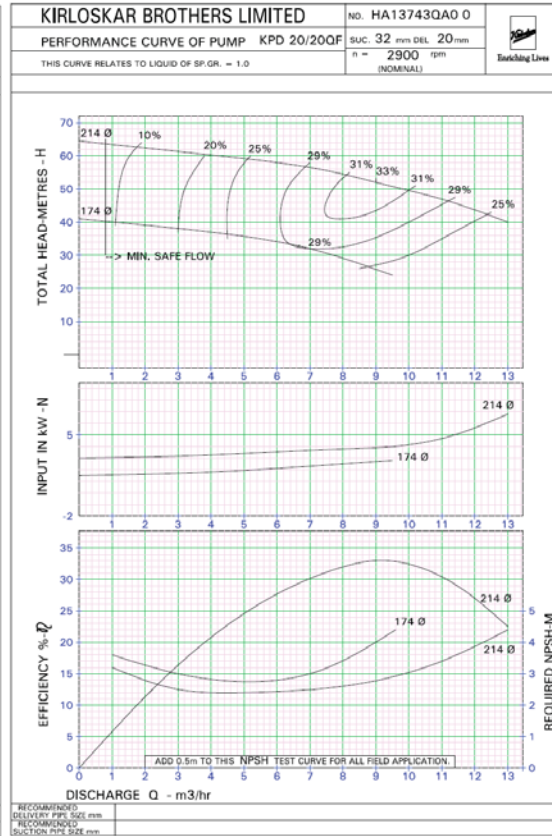
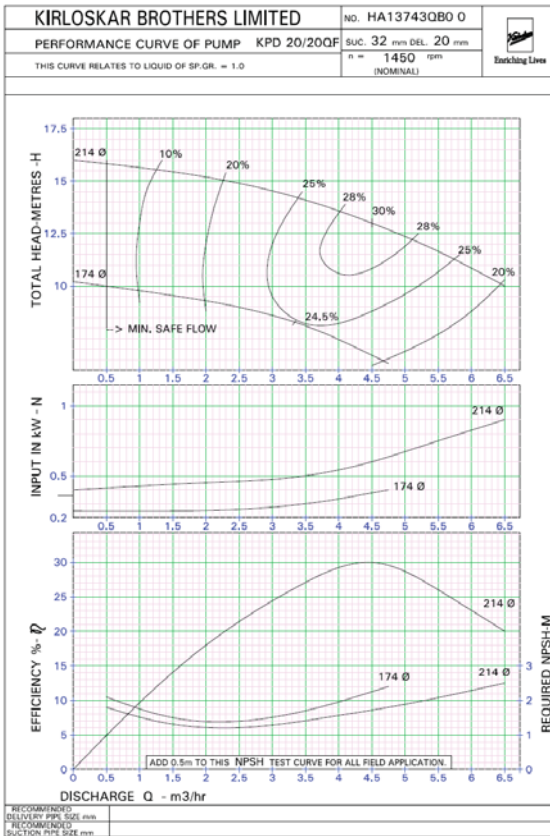

**KIRLOSKAR BROTHERS LIMITED** NO. HD13792AB0 0  
 PERFORMANCE CURVE OF PUMP KPD 25/26A SUC.50 mm DEL.25 mm  
 THIS CURVE RELATES TO LIQUID OF SP.GR. = 1.0 n = 1450 rpm (NOMINAL)

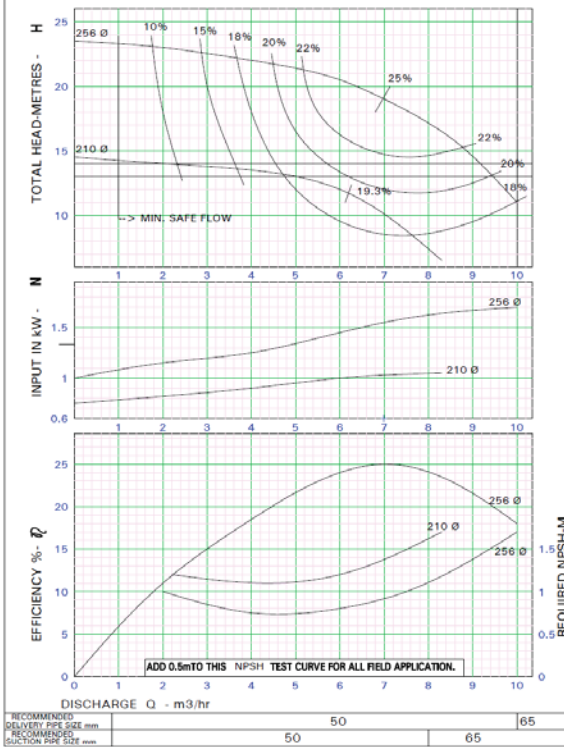

**KIRLOSKAR BROTHERS LIMITED** NO. HD13793AA0 0  
 PERFORMANCE CURVE OF PUMP KPD 25/26A SUC. 50 mm DEL 25 mm  
 THIS CURVE RELATES TO LIQUID OF SP.GR. = 1.0 n = 2900 rpm (NOMINAL)

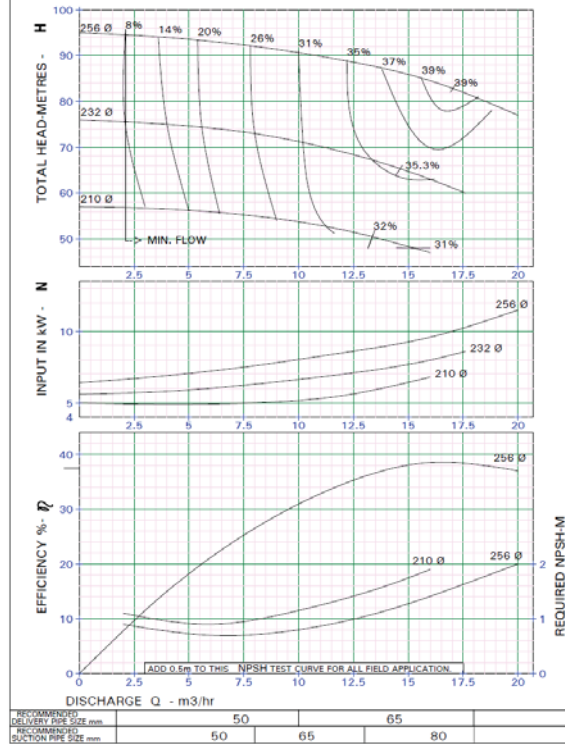

**KIRLOSKAR BROTHERS LIMITED** NO. HD13701KB0 0  
 PERFORMANCE CURVE OF PUMP KPD 32/13 SUC.50 mm DEL.32 mm  
 THIS CURVE RELATES TO LIQUID OF SP.GR. = 1.0 n = 1450 rpm (NOMINAL)

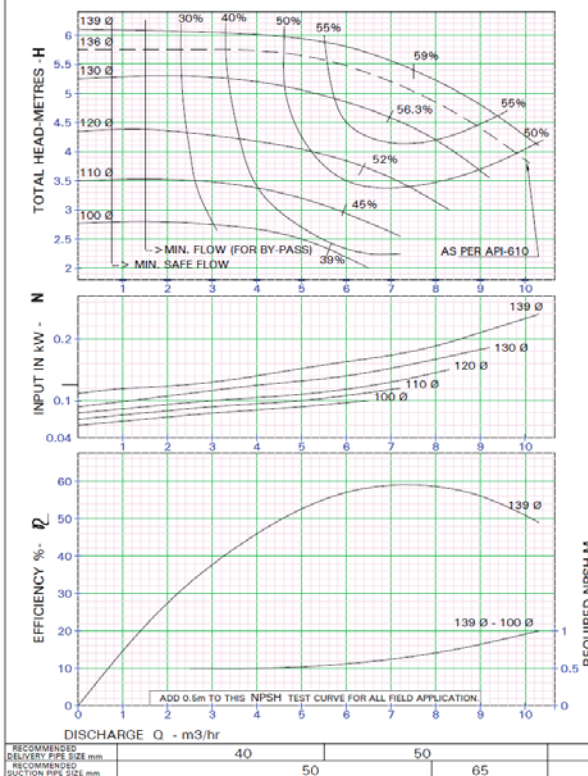

**KIRLOSKAR BROTHERS LIMITED** NO. HD13701KA0 0  
 PERFORMANCE CURVE OF PUMP KPD 32/13 SUC.50mm DEL.32 mm  
 THIS CURVE RELATES TO LIQUID OF SP.GR. = 1.0 n = 2900 rpm (NOMINAL)

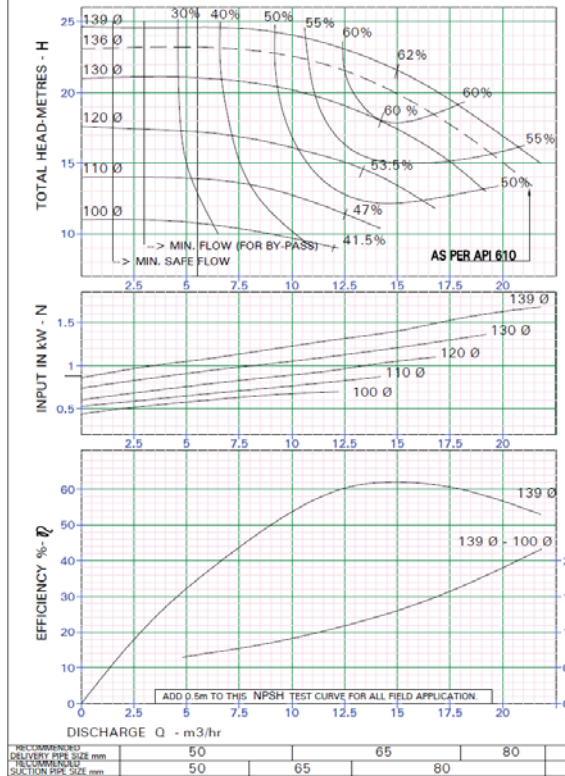

**KIRLOSKAR BROTHERS LIMITED** NO. HA13701QB0 0  
**PERFORMANCE CURVE OF PUMP KPD 32/13QF** SUC. 50 mm DEL. 32 mm  
 n = 1450 rpm (NOMINAL)

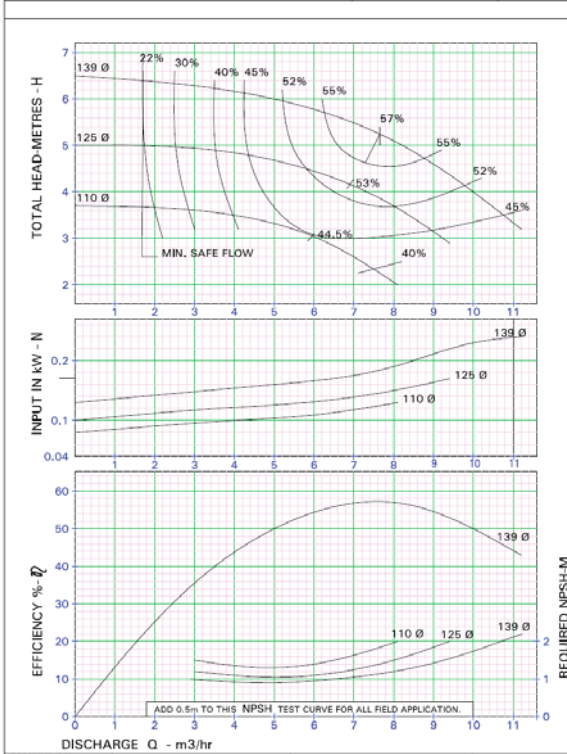

**KIRLOSKAR BROTHERS LIMITED** NO. HA13701QA0 0  
**PERFORMANCE CURVE OF PUMP KPD 32/13QF** SUC. 50 mm DEL. 32 mm  
 n = 2900 rpm (NOMINAL)

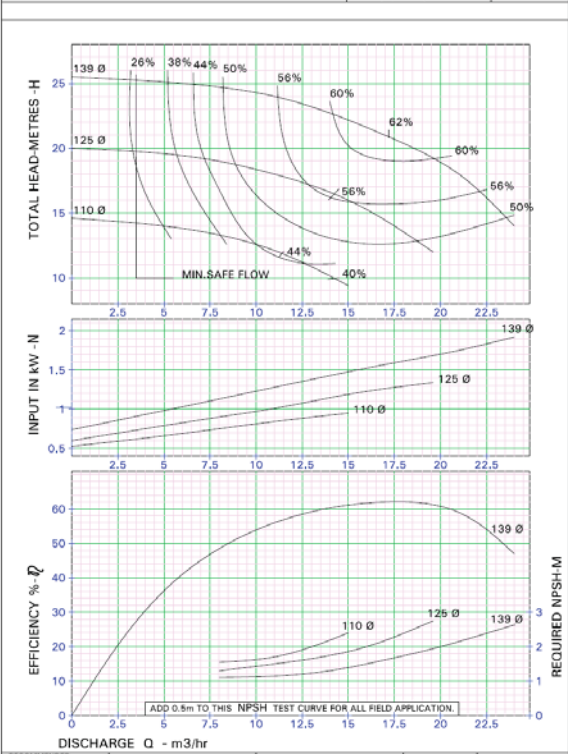

**KIRLOSKAR BROTHERS LIMITED** NO. HD13702KB0 0  
**PERFORMANCE CURVE OF PUMP KPD 32/16** SUC. 50 mm DEL. 32 mm  
 n = 1450 rpm (NOMINAL)

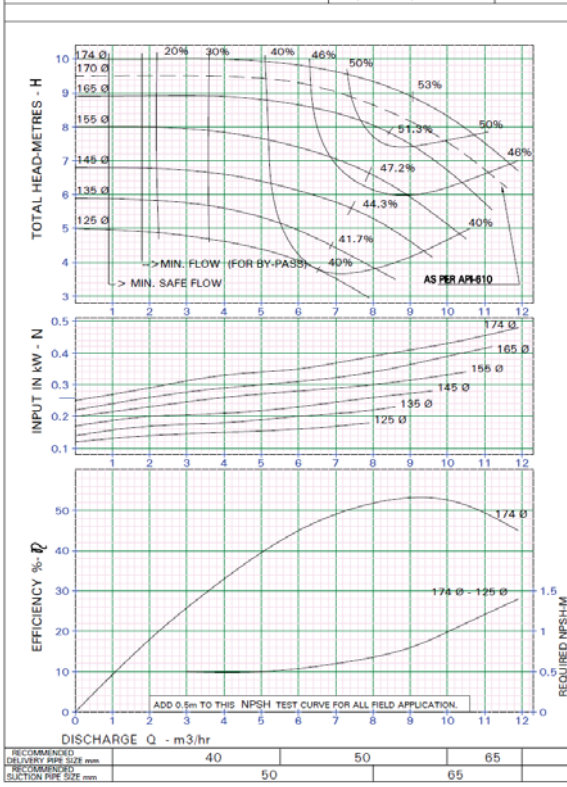

**KIRLOSKAR BROTHERS LIMITED** NO. HD13702KA0 0  
**PERFORMANCE CURVE OF PUMP KPD 32/16** SUC. 50 mm DEL. 32 mm  
 n = 2900 rpm (NOMINAL)

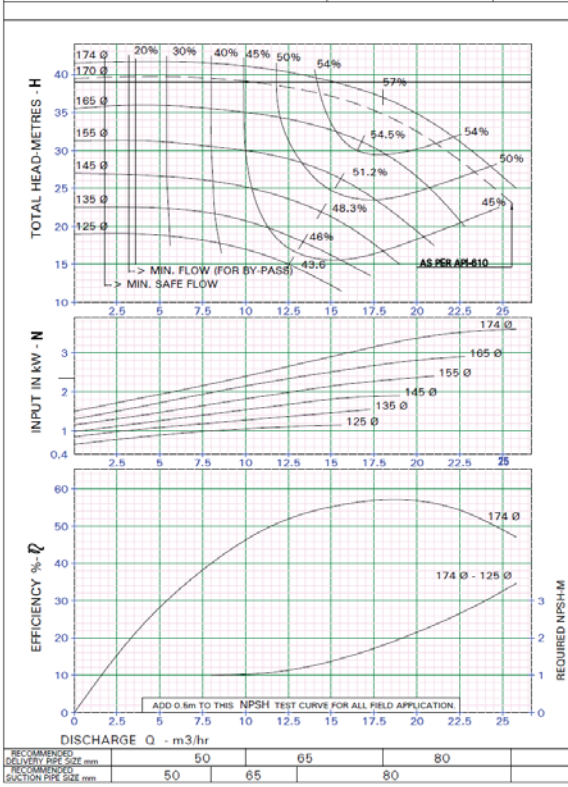

**KIRLOSKAR BROTHERS LIMITED** NO. HD13702AA0 0  
**PERFORMANCE CURVE OF PUMP KPD 32/16A** SUC.50 mm DEL. 32 mm  
 THIS CURVE RELATES TO LIQUID OF SP.GR. = 1.0 n = 2900 rpm (NOMINAL)

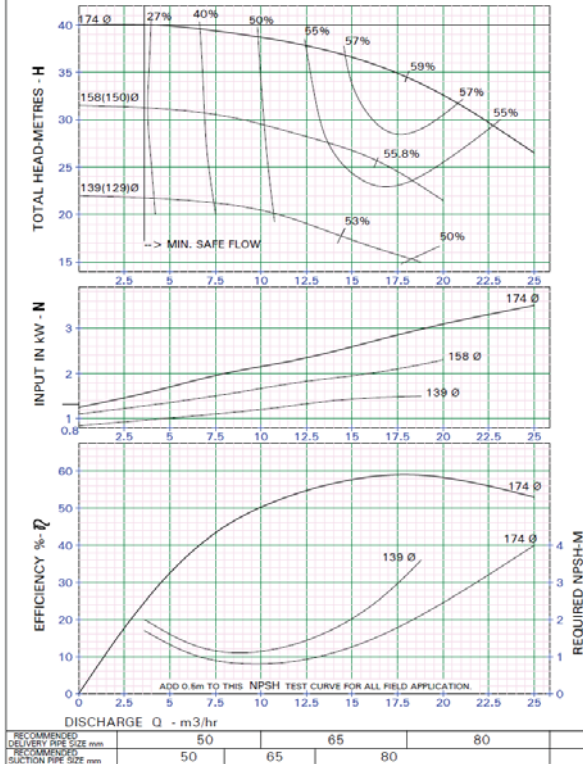

**KIRLOSKAR BROTHERS LIMITED** NO. HA13702QA0 0  
**PERFORMANCE CURVE OF PUMP KPD 32/16QF** SUC. 50 mm DEL. 32 mm  
 THIS CURVE RELATES TO LIQUID OF SP.GR. = 1.0 n = 2900 rpm (NOMINAL)

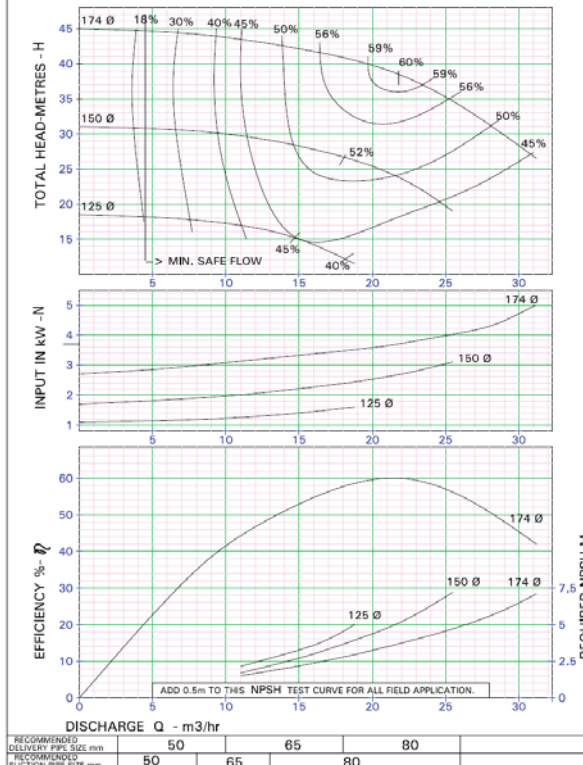

**KIRLOSKAR BROTHERS LIMITED** NO. HA13702QB0 0  
**PERFORMANCE CURVE OF PUMP KPD 32/16 QF** SUC. 50 mm DEL. 32 mm  
 THIS CURVE RELATES TO LIQUID OF SP.GR. = 1.0 n = 1450 rpm (NOMINAL)

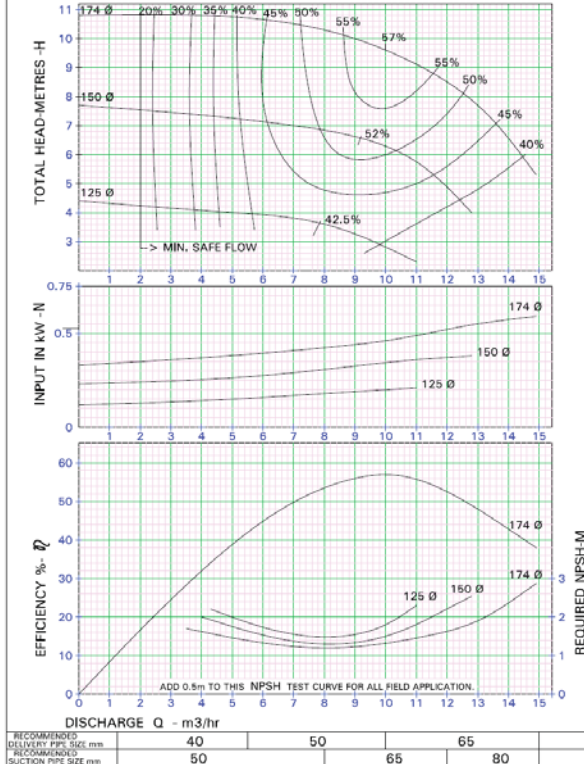

**KIRLOSKAR BROTHERS LIMITED** NO. HD13703KB0 0  
**PERFORMANCE CURVE OF PUMP KPD 32/20** SUC.50 mm DEL. 32 mm  
 THIS CURVE RELATES TO LIQUID OF SP.GR. = 1.0 n = 1450 rpm (NOMINAL)

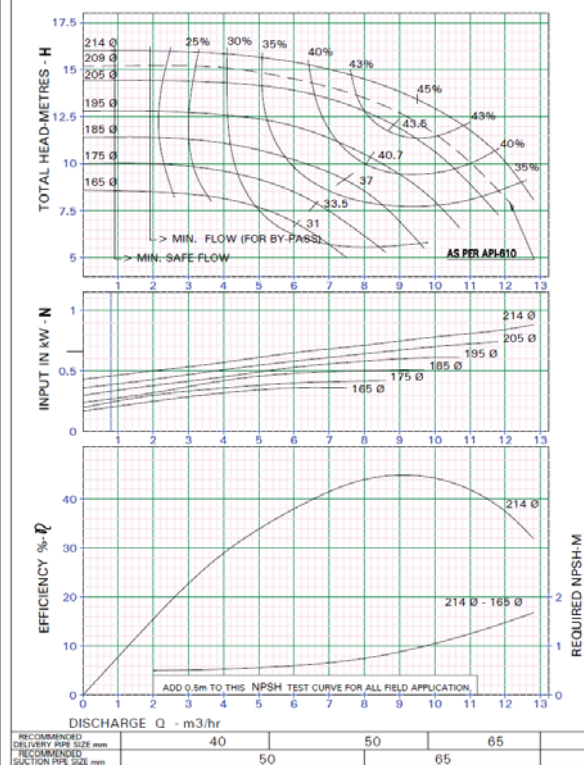

<b>KIRLOSKAR BROTHERS LIMITED</b>	NO. HD13703KA0 0	 Enriching Lives
PERFORMANCE CURVE OF PUMP KPD 32/20	SUC. 50 mm DEL. 32 mm n = 2900 rpm (NOMINAL)	
THIS CURVE RELATES TO LIQUID OF SP.GR. = 1.0		

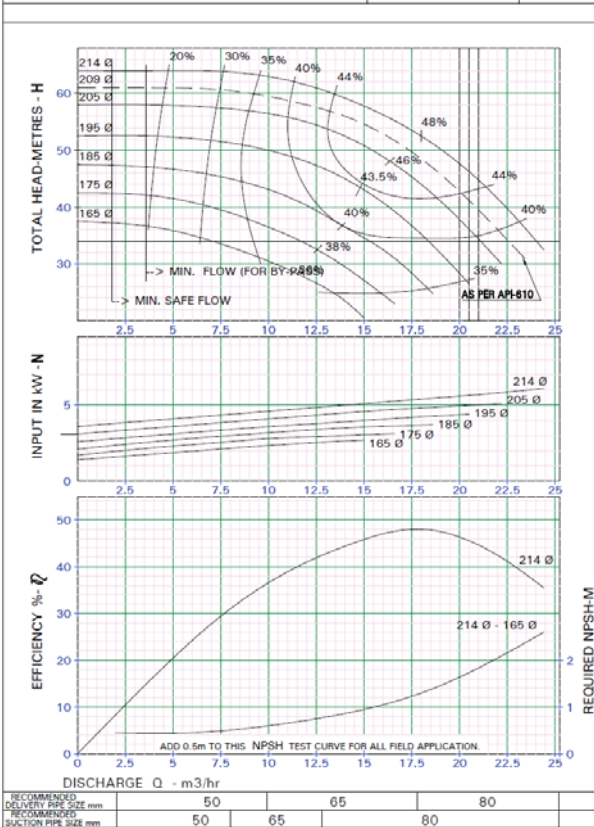

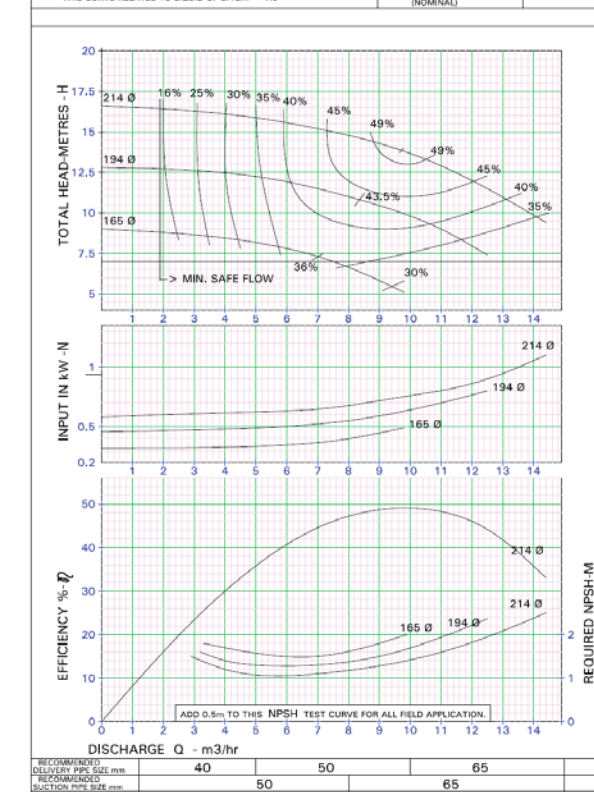

<b>KIRLOSKAR BROTHERS LIMITED</b>	NO. HA13703QA0 0	 Enriching Lives
PERFORMANCE CURVE OF PUMP KPD 32/20 QF	SUC. 50 mm DEL. 32 mm n = 1450 rpm (NOMINAL)	
THIS CURVE RELATES TO LIQUID OF SP.GR. = 1.0		

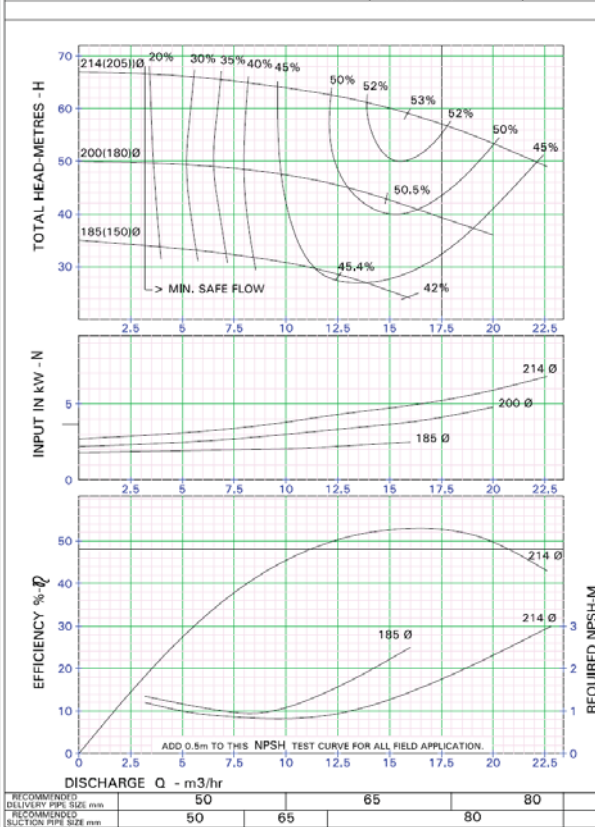

RECOMMENDED DELIVERY PIPE SIZE mm	40	50	65
RECOMMENDED SUCTION PIPE SIZE mm	50		65

<b>KIRLOSKAR BROTHERS LIMITED</b>	NO. HD13703AA0 0	 Enriching Lives
PERFORMANCE CURVE OF PUMP KPD 32-20A	SUC. 50 mm DEL. 32 mm n = 2900 rpm (NOMINAL)	
THIS CURVE RELATES TO LIQUID OF SP.GR. = 1.0		



<b>KIRLOSKAR BROTHERS LIMITED</b>	NO. HA13703QA0 0	 Enriching Lives
PERFORMANCE CURVE OF PUMP KPD 32/20 QF	SUC. 50 mm DEL. 32 mm n = 2900 rpm (NOMINAL)	
THIS CURVE RELATES TO LIQUID OF SP.GR. = 1.0		

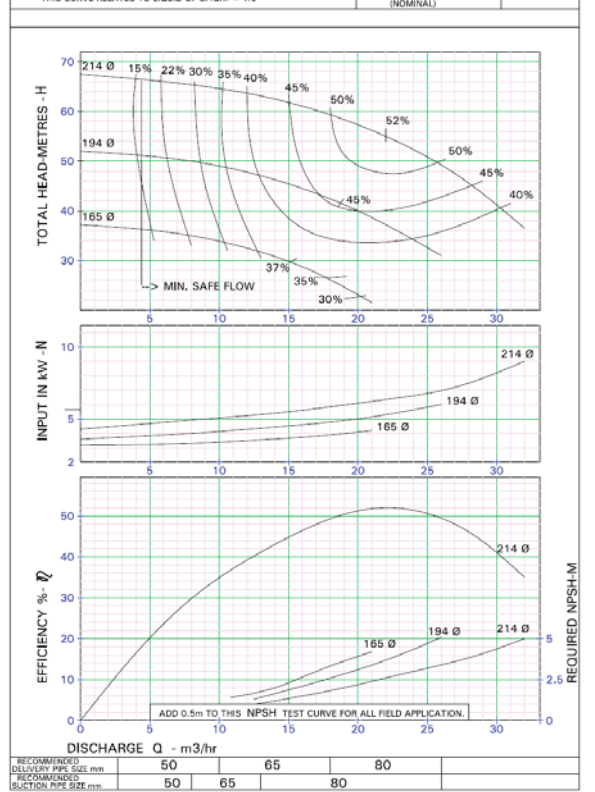

RECOMMENDED DELIVERY PIPE SIZE mm	50	65	80
RECOMMENDED SUCTION PIPE SIZE mm	50	65	80

<b>KIRLOSKAR BROTHERS LIMITED</b>	NO. HD13704KB0 0	
PERFORMANCE CURVE OF PUMP KPD 32/26	SUC. 50 mm DEL 32 mm	
THIS CURVE RELATES TO LIQUID OF SP.GR. = 1.0		
n = 1450 rpm (NOMINAL)		

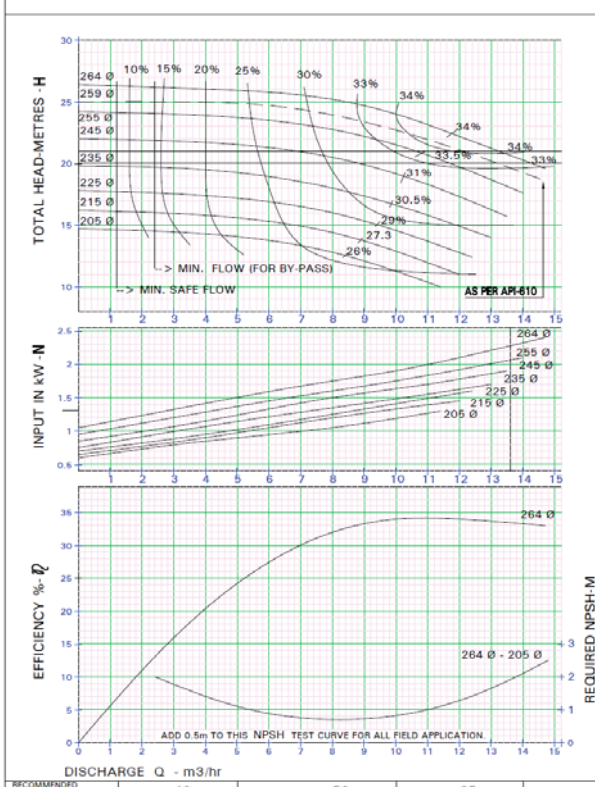

<b>KIRLOSKAR BROTHERS LIMITED</b>	NO. HD13745KA0 0	
PERFORMANCE CURVE OF PUMP KPD 32/26	SUC. 50 mm DEL 32 mm	
THIS CURVE RELATES TO LIQUID OF SP.GR. = 1.0		
n = 2900 rpm (NOMINAL)		

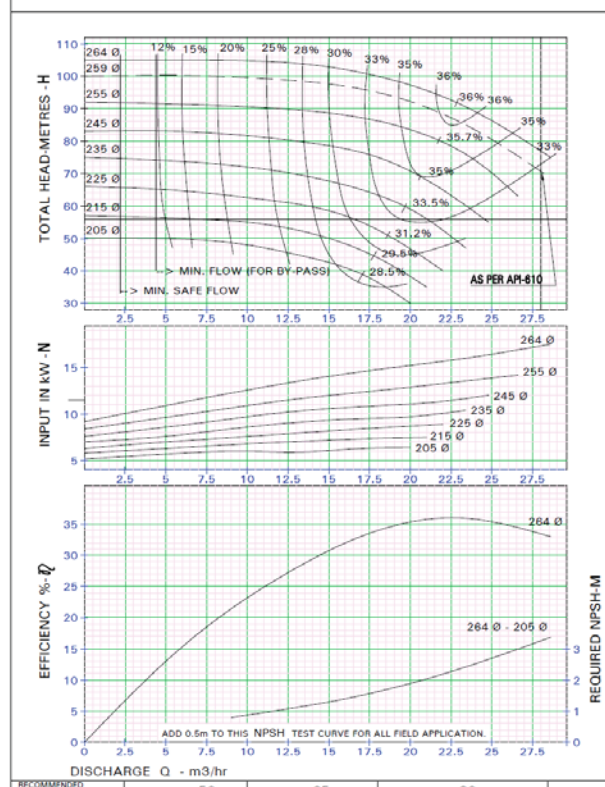

<b>KIRLOSKAR BROTHERS LIMITED</b>	NO. HA13704QB0 0	
PERFORMANCE CURVE OF PUMP KPD 32/26 QF	SUC. 50 mm DEL 32 mm	
THIS CURVE RELATES TO LIQUID OF SP.GR. = 1.0		
n = 1450 rpm (NOMINAL)		

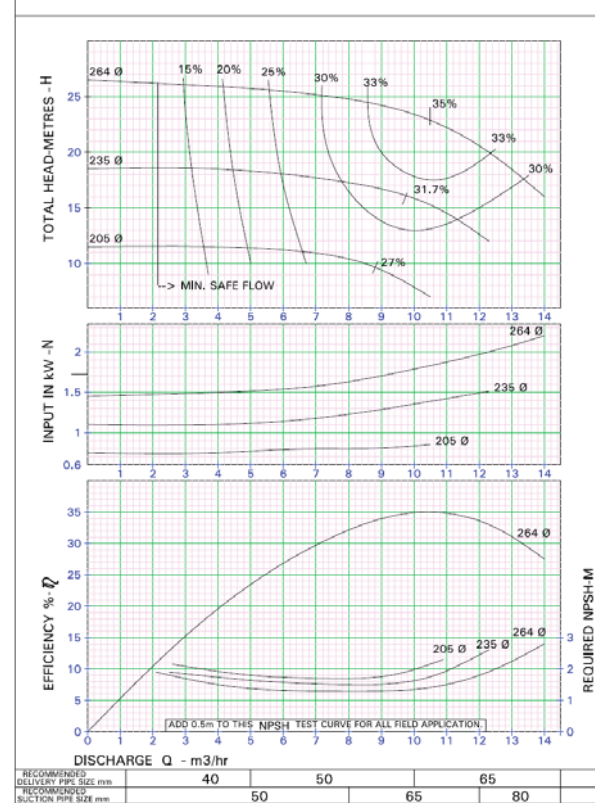

<b>KIRLOSKAR BROTHERS LIMITED</b>	NO. HA13704QA0 0	
PERFORMANCE CURVE OF PUMP KPD 32/26 QF	SUC. 50 mm DEL 32 mm	
THIS CURVE RELATES TO LIQUID OF SP.GR. = 1.0		
n = 2900 rpm (NOMINAL)		

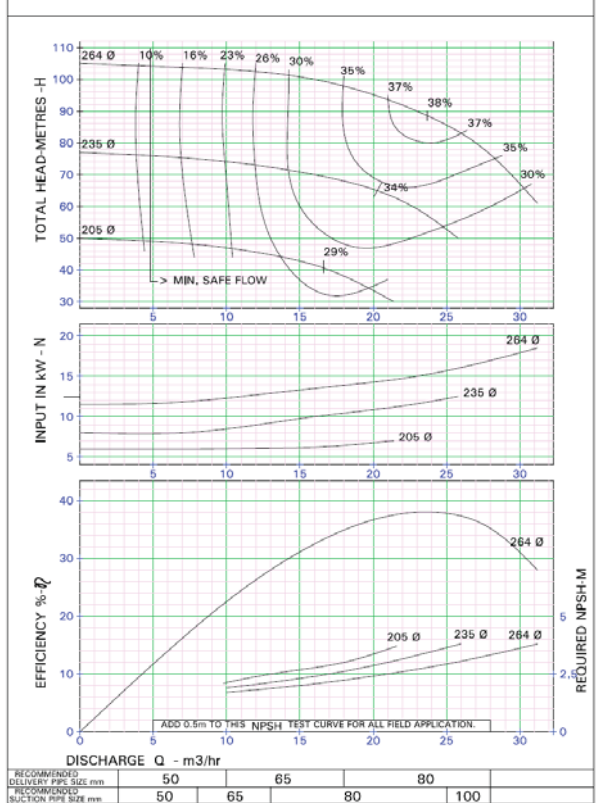

<b>KIRLOSKAR BROTHERS LIMITED</b>	NO. HD13705KB0 0		
	PERFORMANCE CURVE OF PUMP KPD 40/13		SUC. 85 mm DEL. 40 mm n = 1450 rpm NOMINAL
	THIS CURVE RELATES TO LIQUID OF SP.GR. = 1.0		

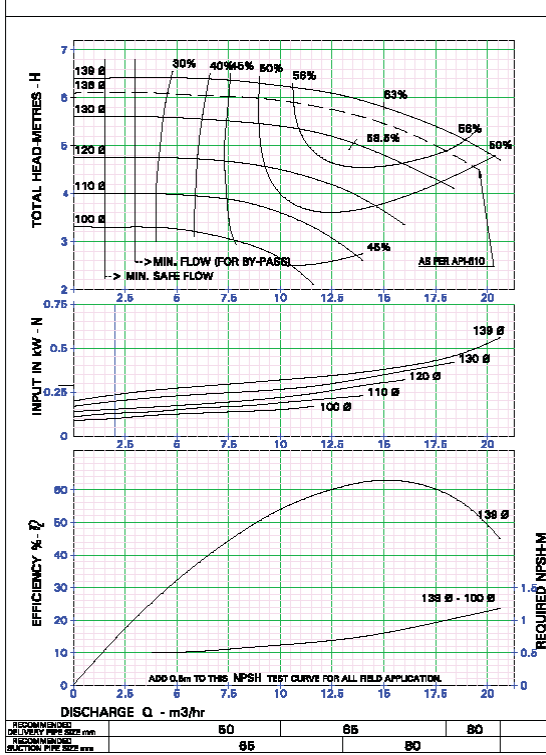

<b>KIRLOSKAR BROTHERS LIMITED</b>	NO. HD13705KAO 0		
	PERFORMANCE CURVE OF PUMP KPD 40/13		SUC. 85 mm DEL. 40 mm n = 2800 rpm NOMINAL
	THIS CURVE RELATES TO LIQUID OF SP.GR. = 1.0		

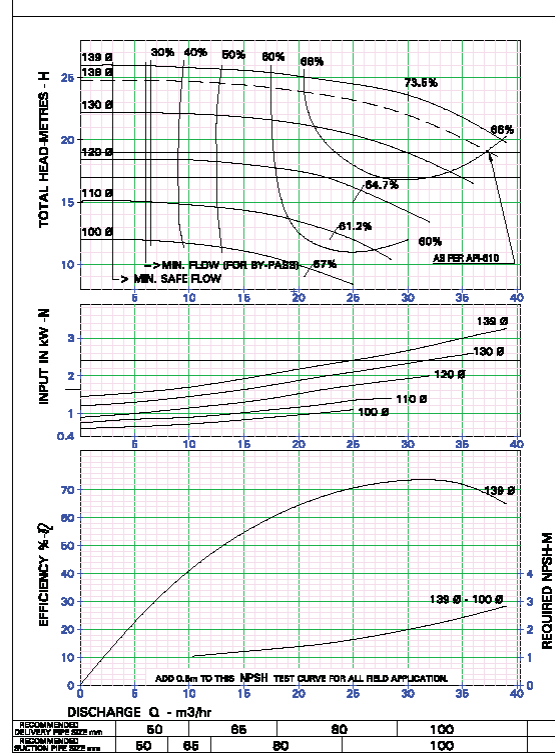

<b>KIRLOSKAR BROTHERS LIMITED</b>	NO. HA13705QB0 0		
	PERFORMANCE CURVE OF PUMP KPD 40/13 QF		SUC. 85 mm DEL. 40 mm n = 1450 rpm NOMINAL
	THIS CURVE RELATES TO LIQUID OF SP.GR. = 1.0		

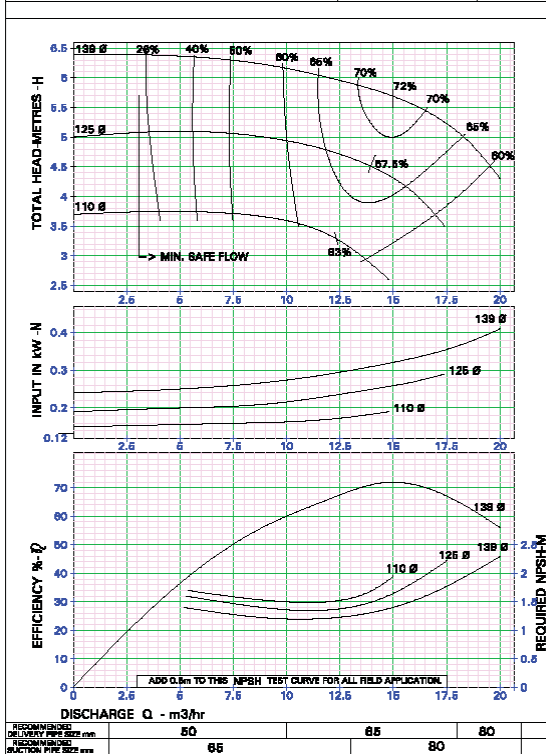

<b>KIRLOSKAR BROTHERS LIMITED</b>	NO. HA13705QA0 0		
	PERFORMANCE CURVE OF PUMP KPD 40/13 QF		SUC. 85 mm DEL. 40 mm n = 2800 rpm NOMINAL
	THIS CURVE RELATES TO LIQUID OF SP.GR. = 1.0		

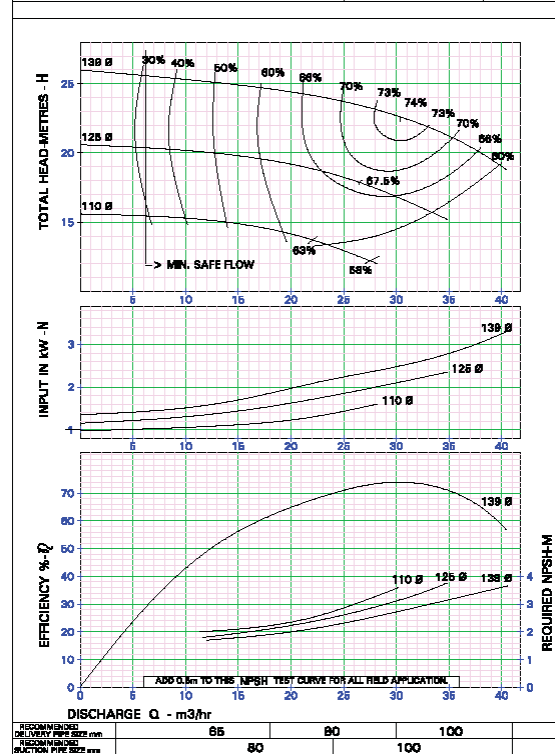

<b>KIRLOSKAR BROTHERS LIMITED</b>	NO. HD13708KB0 0		
	PERFORMANCE CURVE OF PUMP KPD 40/16		SUC. 85 mm DEL. 40 mm
	n = 1450 rpm		NOMINAL
THIS CURVE RELATES TO LIQUID OF SP.GR. = 1.0			

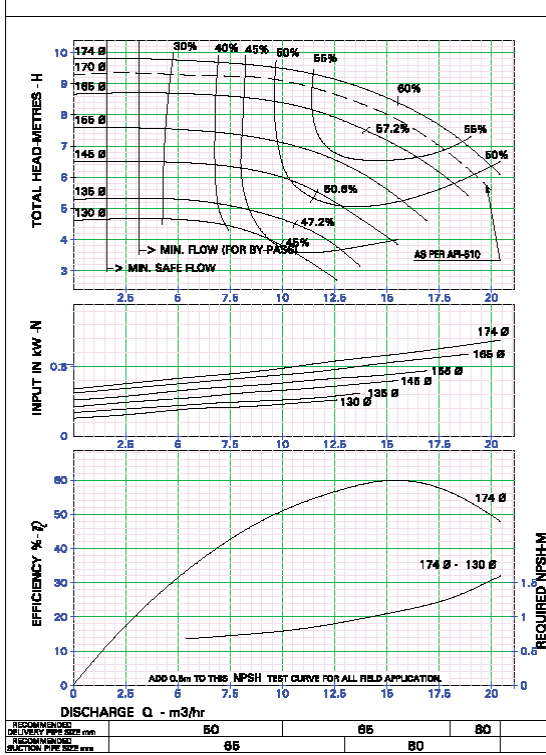

<b>KIRLOSKAR BROTHERS LIMITED</b>	NO. HD13708KA0 0		
	PERFORMANCE CURVE OF PUMP KPD 40/16		SUC. 85 mm DEL. 40 mm
	n = 2800 rpm		NOMINAL
THIS CURVE RELATES TO LIQUID OF SP.GR. = 1.0			

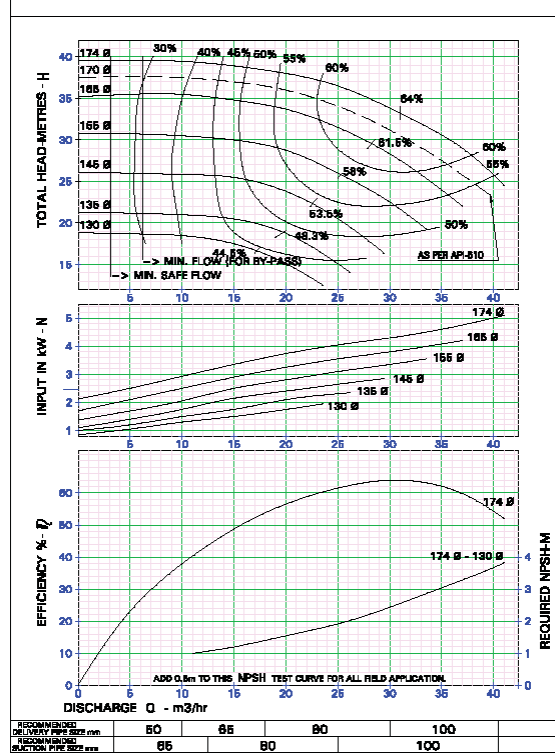

<b>KIRLOSKAR BROTHERS LIMITED</b>	NO. HA13708QB0 0		
	PERFORMANCE CURVE OF PUMP KPD 40/18QF		SUC. 85 mm DEL. 40 mm
	n = 1450 rpm		NOMINAL
THIS CURVE RELATES TO LIQUID OF SP.GR. = 1.0			

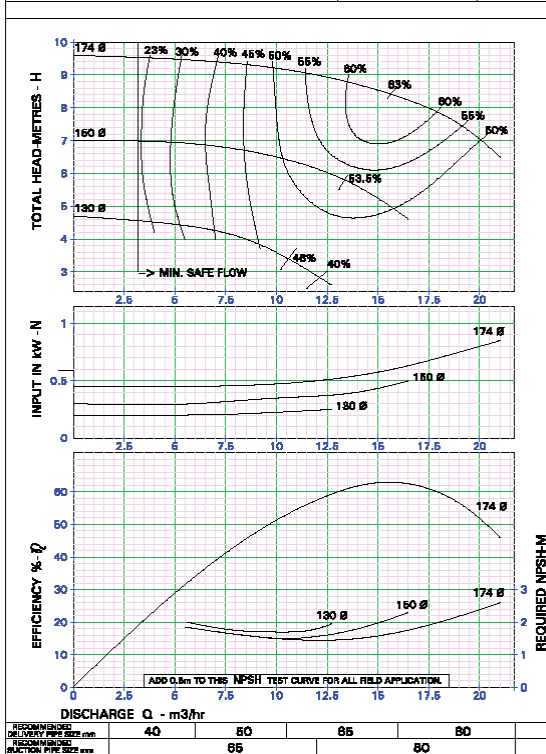

<b>KIRLOSKAR BROTHERS LIMITED</b>	NO. HA13708QA0 0		
	PERFORMANCE CURVE OF PUMP KPD 40/18QF		SUC. 85 mm DEL. 40 mm
	n = 2800 rpm		NOMINAL
THIS CURVE RELATES TO LIQUID OF SP.GR. = 1.0			

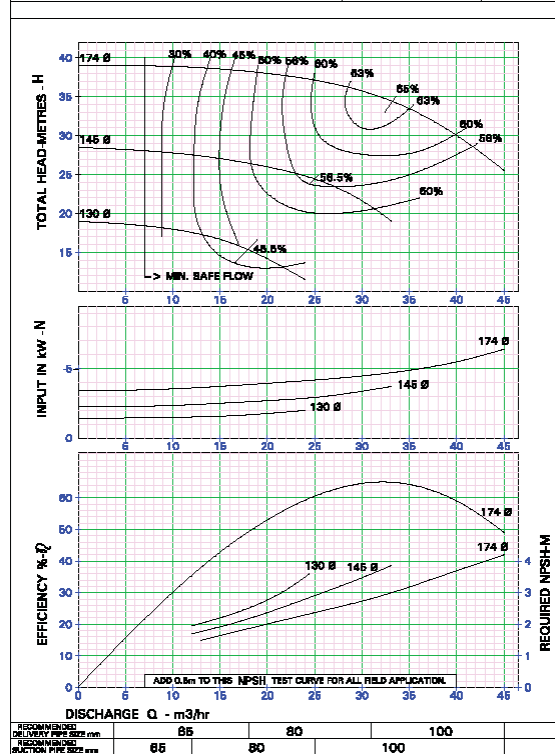

<b>KIRLOSKAR BROTHERS LIMITED</b>		NO. HD13707KBO 0	
PERFORMANCE CURVE OF PUMP KPD 40/20		SUC. 85 mm DEL. 40mm	
THIS CURVE RELATED TO LIQUID OF SP.GR. = 1.0		n = 1450 rpm	NOMINAL

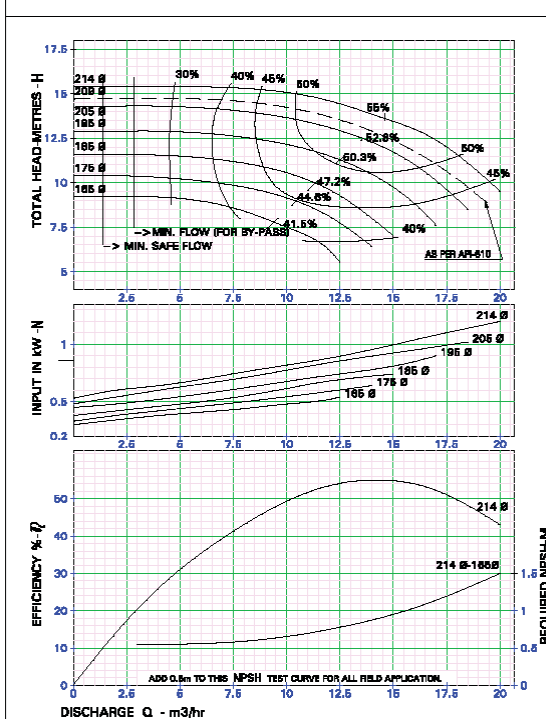

<b>KIRLOSKAR BROTHERS LIMITED</b>		NO. HD13707KAD 0	
PERFORMANCE CURVE OF PUMP KPD 40/20		SUC. 85 mm DEL. 40mm	
THIS CURVE RELATED TO LIQUID OF SP.GR. = 1.0		n = 2900 rpm	NOMINAL

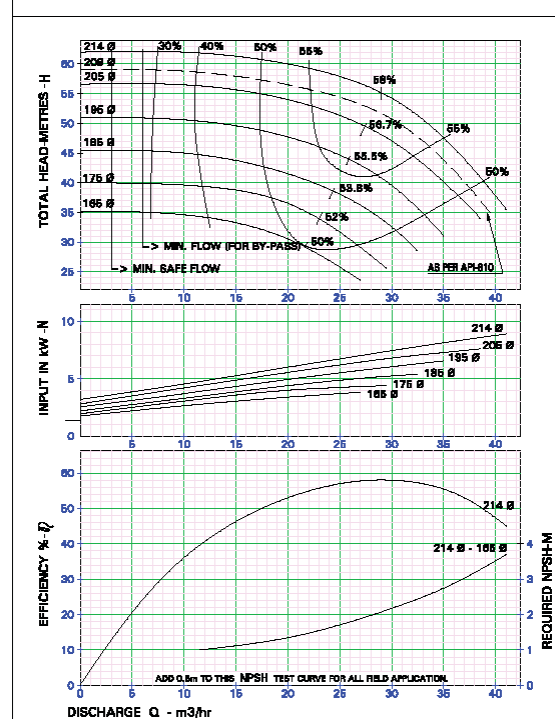

<b>KIRLOSKAR BROTHERS LIMITED</b>		NO. HD13707AAO 0	
PERFORMANCE CURVE OF PUMP KPD 40-20A		SUC. 85 mm DEL. 40mm	
THIS CURVE RELATED TO LIQUID OF SP.GR. = 1.0		n = 2900 rpm	NOMINAL

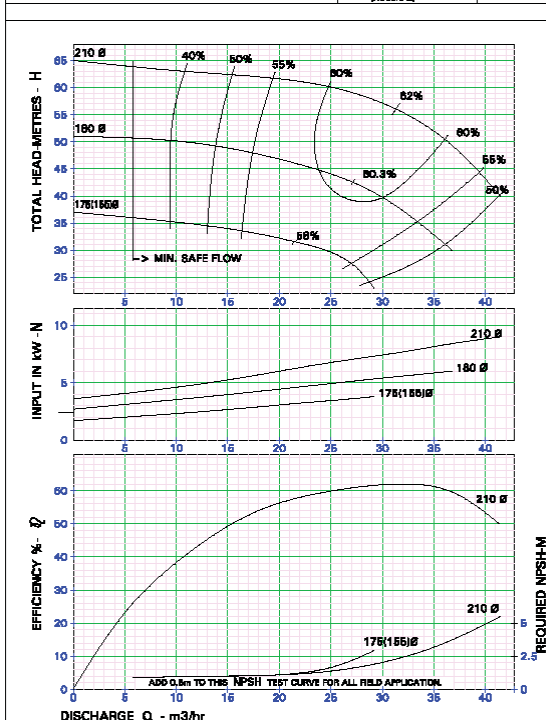

<b>KIRLOSKAR BROTHERS LIMITED</b>		NO. HA13707QBO 0	
PERFORMANCE CURVE OF PUMP KPD 40/20QF		SUC. 85 mm DEL. 40mm	
THIS CURVE RELATED TO LIQUID OF SP.GR. = 1.0		n = 1450 rpm	NOMINAL

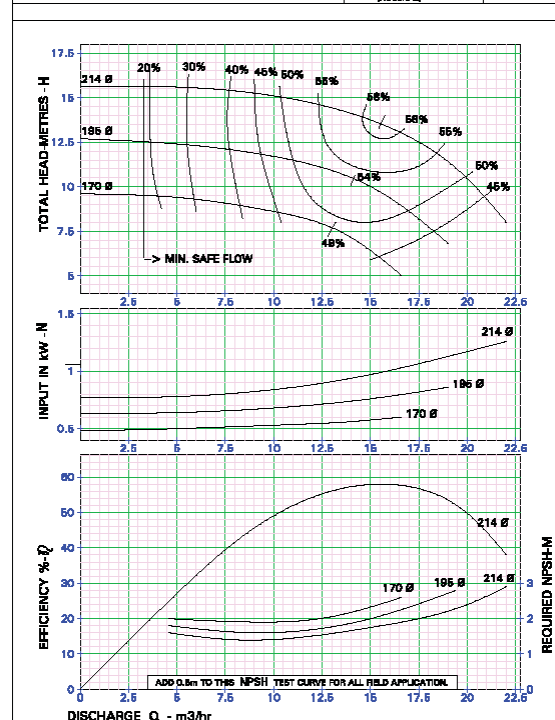

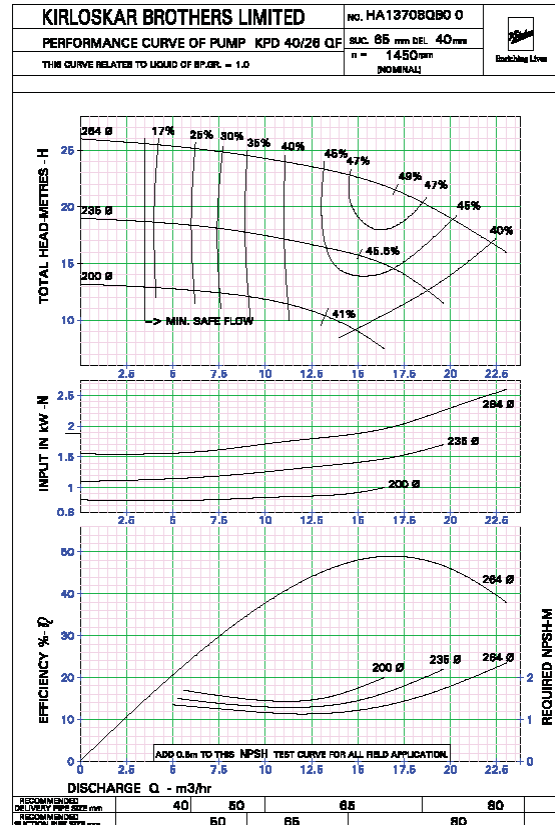
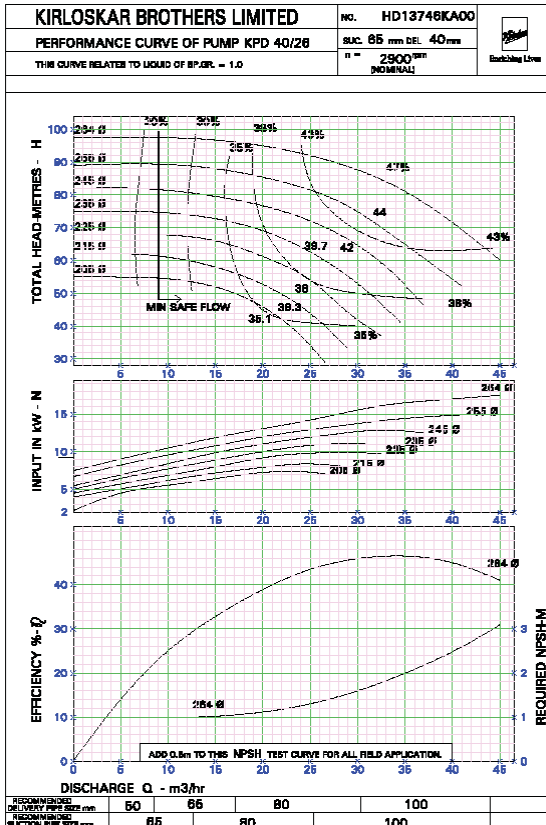
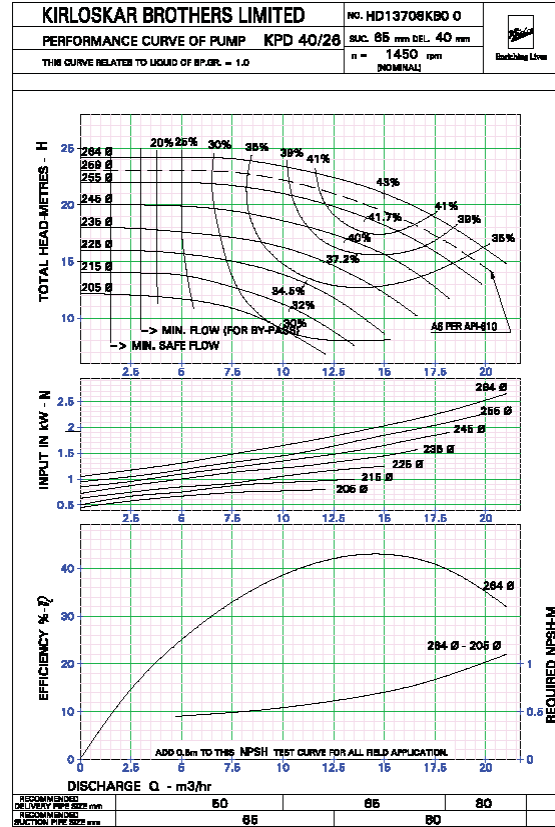
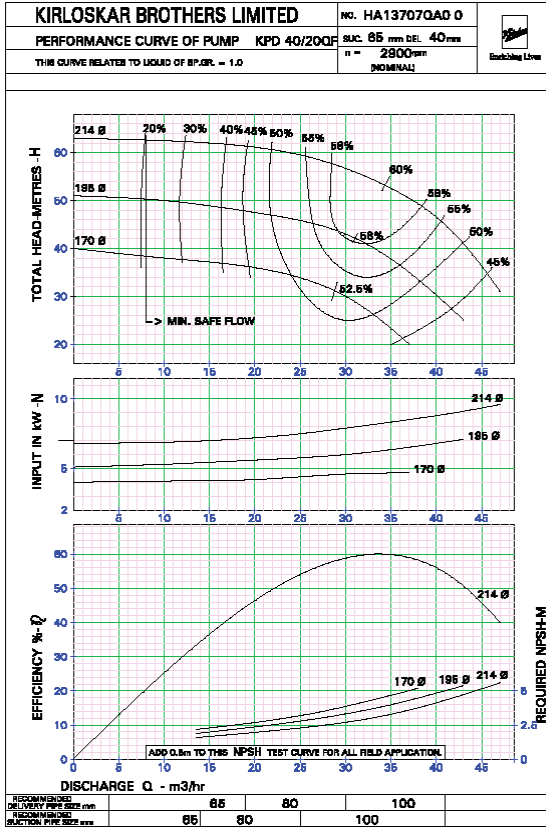

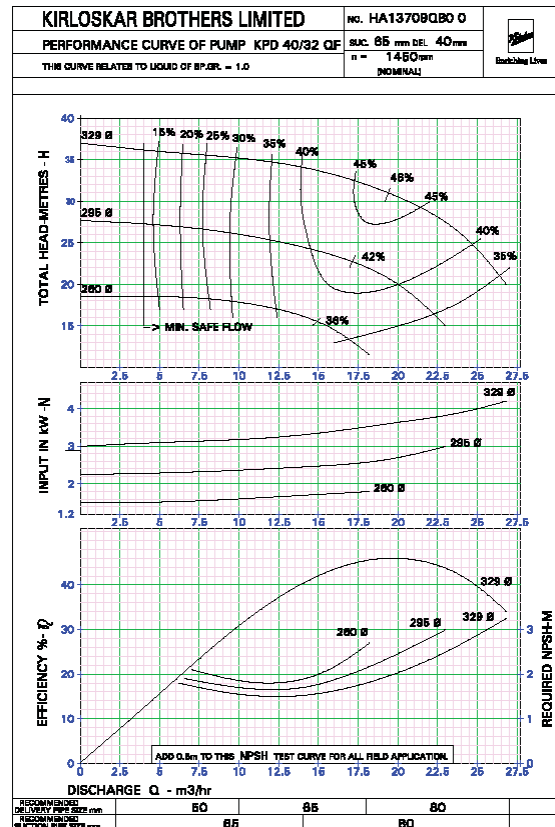
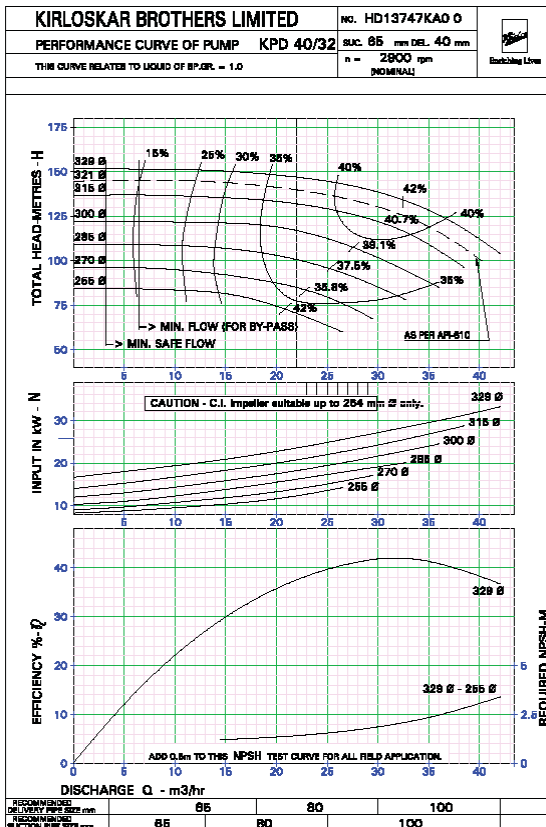
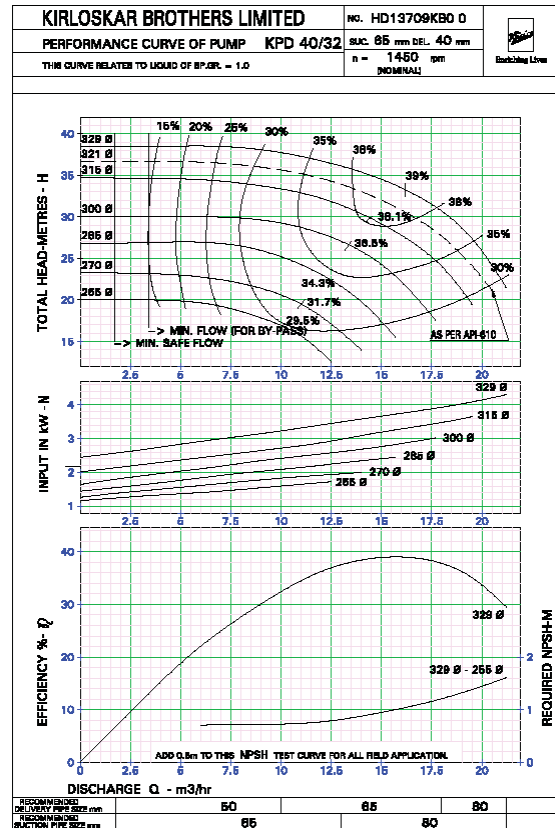
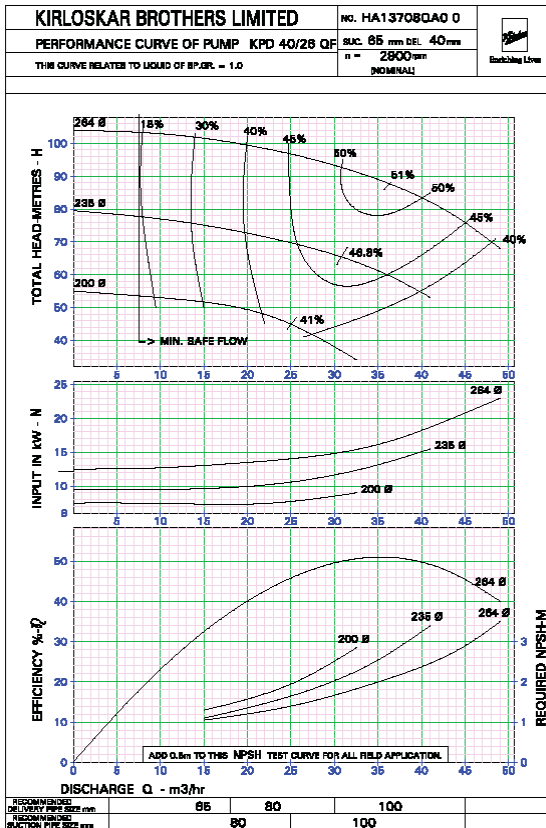

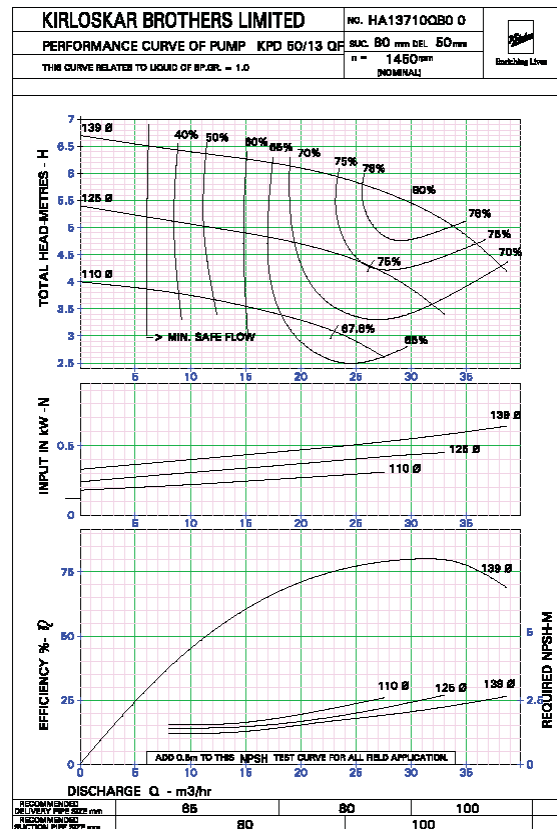
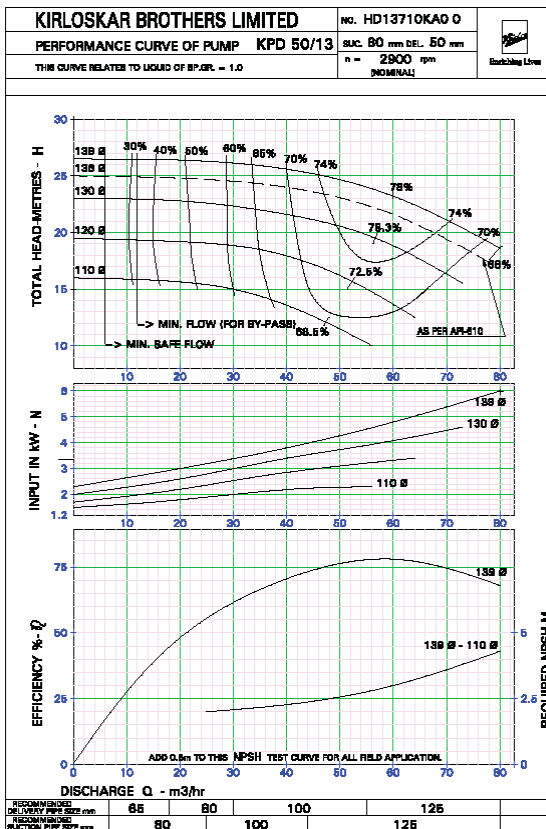
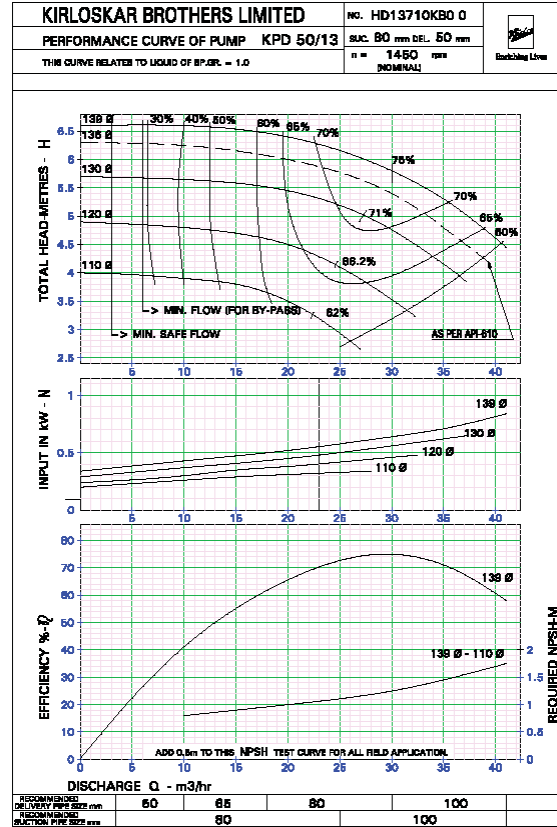
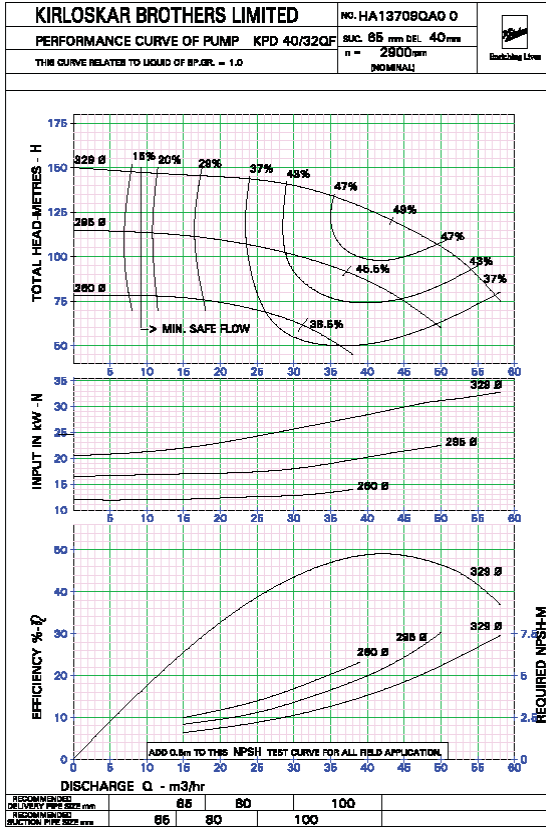

<b>KIRLOSKAR BROTHERS LIMITED</b>	NO. HA13710QA0 0	
<b>PERFORMANCE CURVE OF PUMP KPD 50/13 QF</b>	SUC. 80 mm DEL. 50 mm n = 2800 rpm NOMINAL	
THIS CURVE RELATED TO LIQUID OF SP.GR. = 1.0		

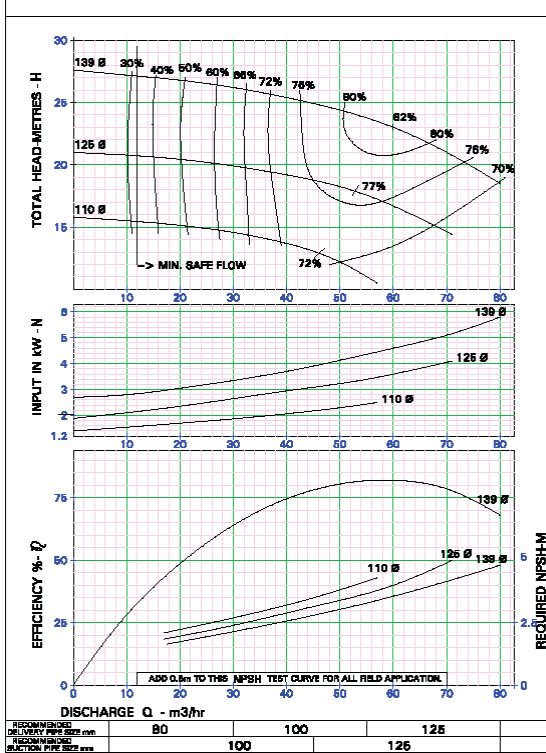

<b>KIRLOSKAR BROTHERS LIMITED</b>	NO. HD13711KB0 0	
<b>PERFORMANCE CURVE OF PUMP KPD 50/16</b>	SUC. 80 mm DEL. 50 mm n = 1450 rpm NOMINAL	
THIS CURVE RELATED TO LIQUID OF SP.GR. = 1.0		

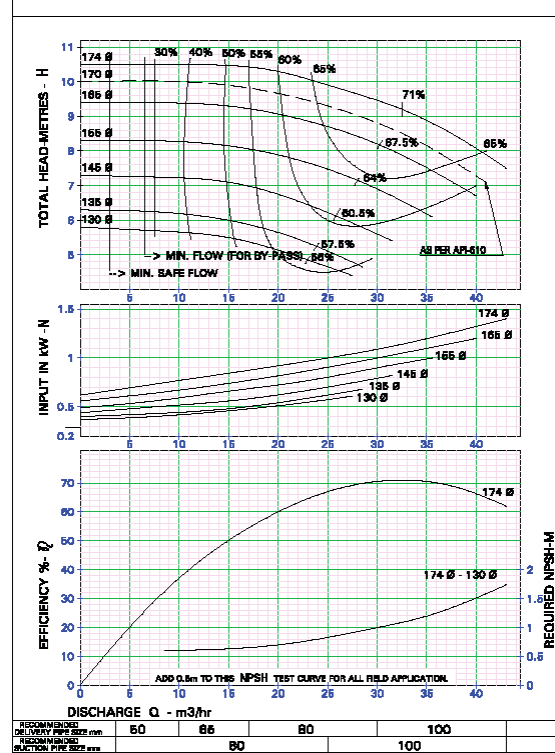

<b>KIRLOSKAR BROTHERS LIMITED</b>	NO. HD13711KA0 0	
<b>PERFORMANCE CURVE OF PUMP KPD 50/16</b>	SUC. 80 mm DEL. 50 mm n = 2800 rpm NOMINAL	
THIS CURVE RELATED TO LIQUID OF SP.GR. = 1.0		

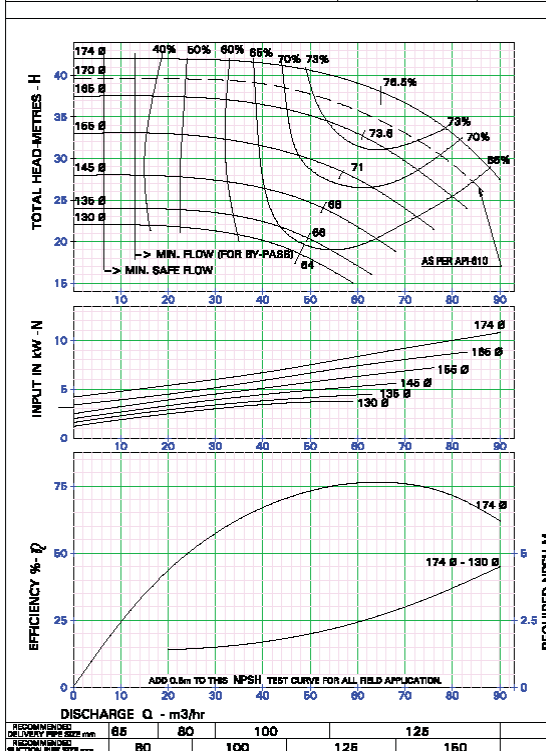

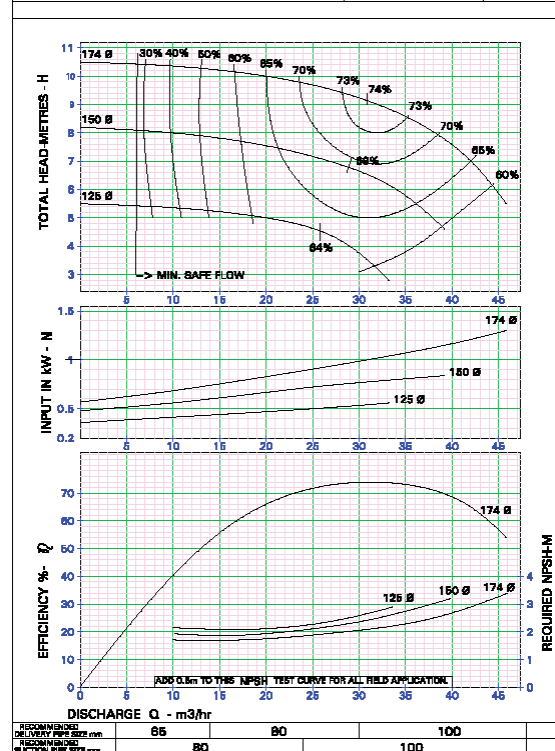

<b>KIRLOSKAR BROTHERS LIMITED</b>	NO. HA13711QB0 0	
<b>PERFORMANCE CURVE OF PUMP KPD 50/16QF</b>	SUC. 80 mm DEL. 50 mm n = 1450 rpm NOMINAL	
THIS CURVE RELATED TO LIQUID OF SP.GR. = 1.0		

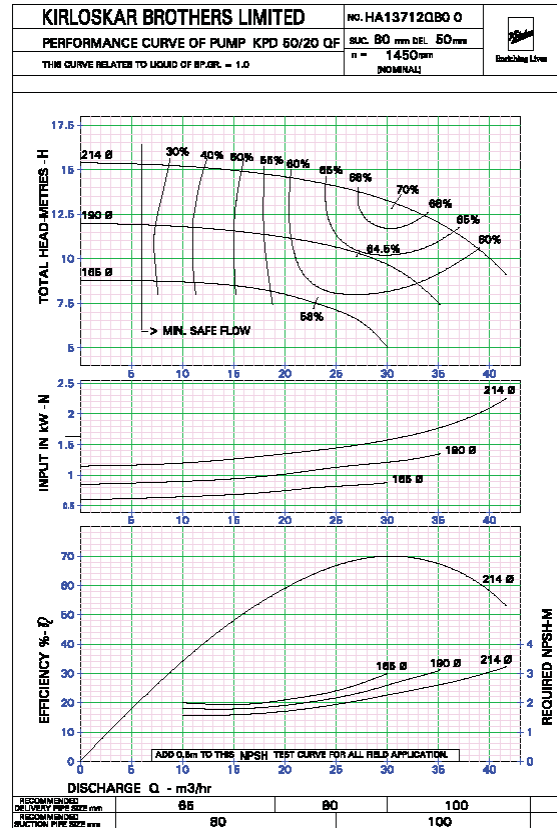
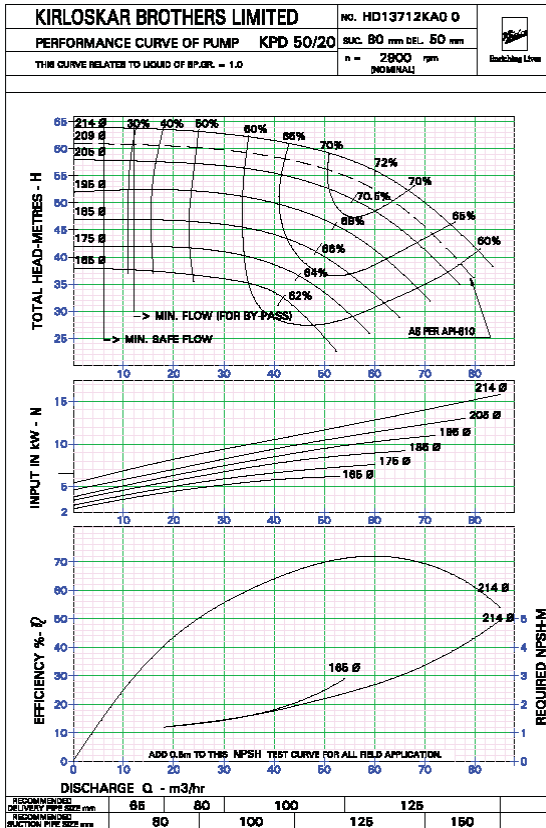
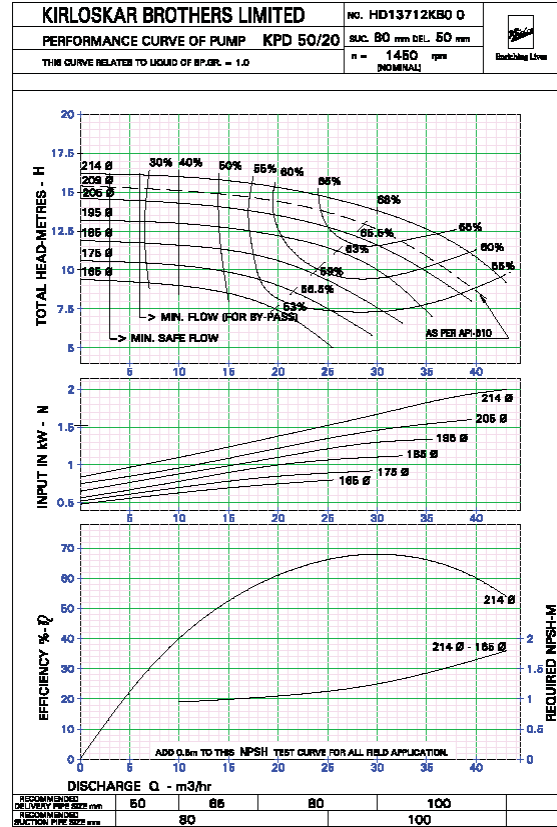
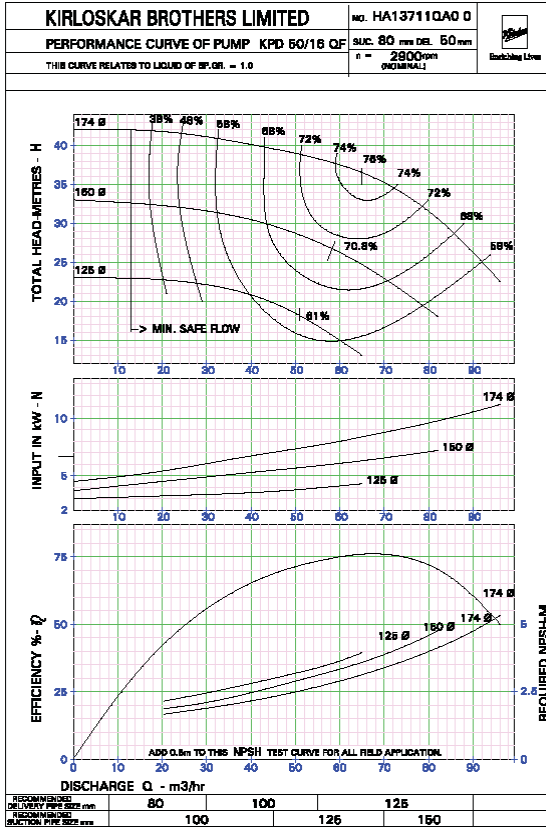

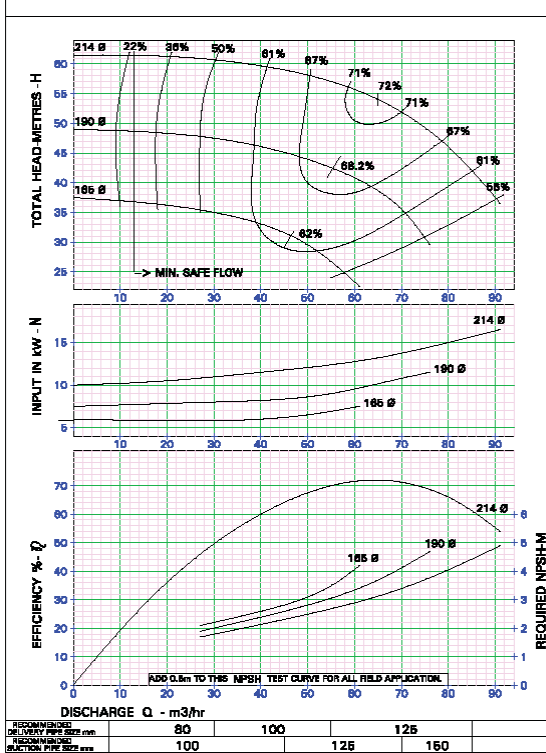

<b>KIRLOSKAR BROTHERS LIMITED</b>	NO. HA13712QAO 0	
PERFORMANCE CURVE OF PUMP KPD 50/20 QF	SUC. 80 mm DEL. 50 mm	
THIS CURVE RELATES TO LIQUID OF SP.GR. = 1.0	n = 2900 rpm	
	NOMINAL	



<b>KIRLOSKAR BROTHERS LIMITED</b>	NO. HD13713KBO 0	
PERFORMANCE CURVE OF PUMP KPD 50/28	SUC. 80 mm DEL. 50 mm	
THIS CURVE RELATES TO LIQUID OF SP.GR. = 1.0	n = 1450 rpm	
	NOMINAL	

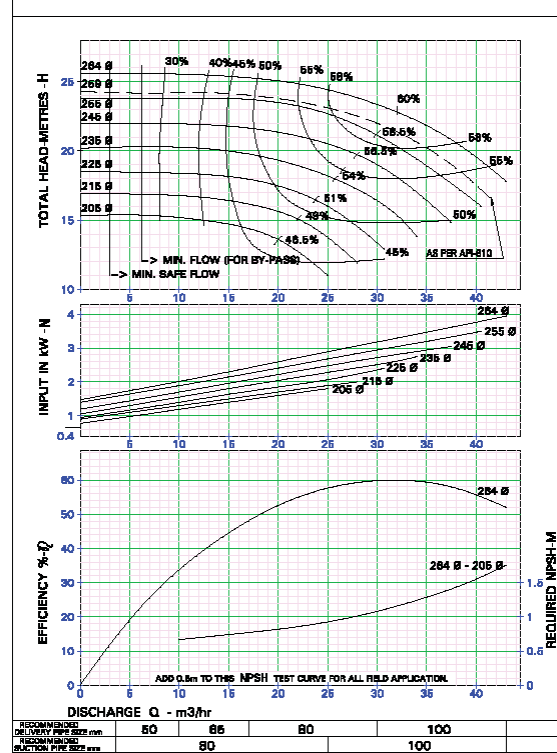

<b>KIRLOSKAR BROTHERS LIMITED</b>	NO. HD13749KAO 0	
PERFORMANCE CURVE OF PUMP KPD 50/28	SUC. 80 mm DEL. 50 mm	
THIS CURVE RELATES TO LIQUID OF SP.GR. = 1.0	n = 2900 rpm	
	NOMINAL	

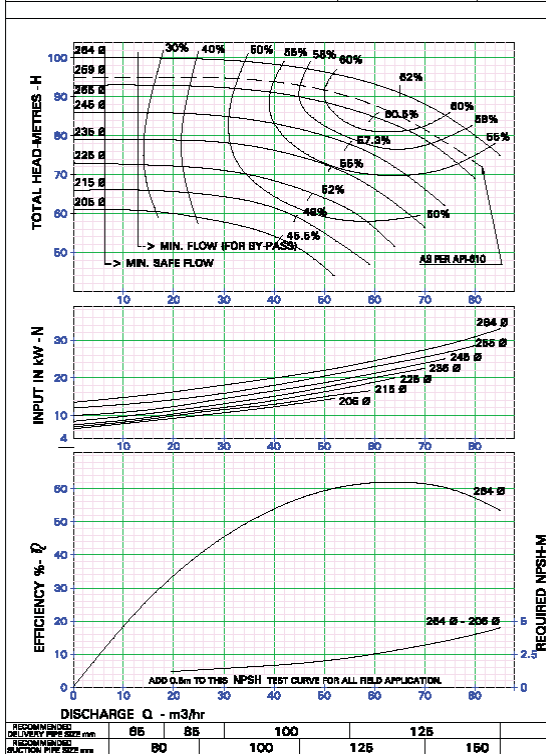

<b>KIRLOSKAR BROTHERS LIMITED</b>	NO. HA13713QB0 0	
PERFORMANCE CURVE OF PUMP KPD 50/28QF	SUC. 80 mm DEL. 50 mm	
THIS CURVE RELATES TO LIQUID OF SP.GR. = 1.0	n = 1450 rpm	
	NOMINAL	

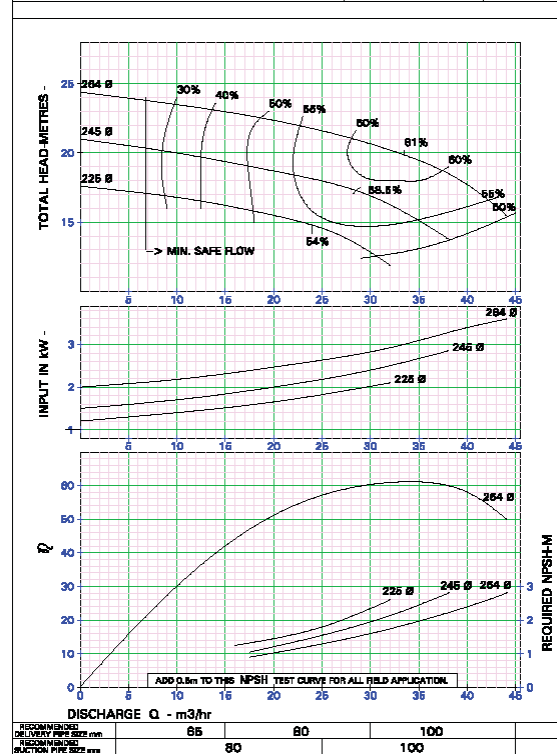

<b>KIRLOSKAR BROTHERS LIMITED</b>	NO. HA13713QA0 0		
	PERFORMANCE CURVE OF PUMP KPD 50/28QF		SUC. 80 mm DEL. 50 mm n = 2900 rpm NOMINAL
	THIS CURVE RELATES TO LIQUID OF SP.GR. = 1.0		

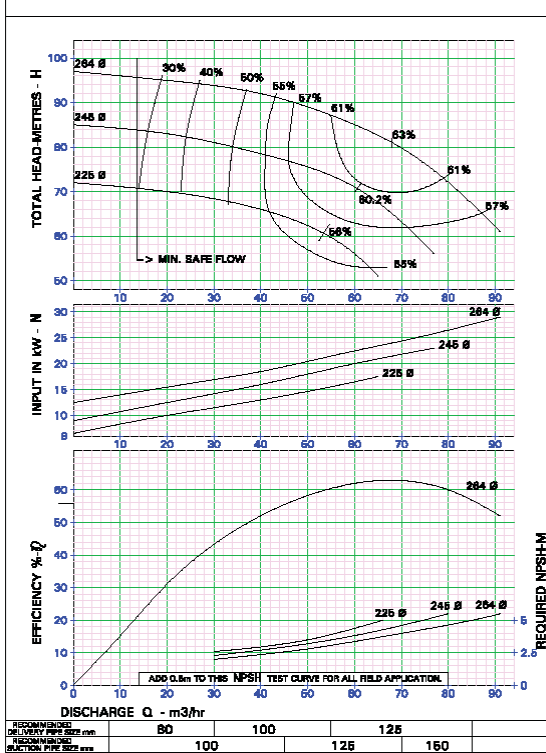

<b>KIRLOSKAR BROTHERS LIMITED</b>	NO. HD13714KB0 0		
	PERFORMANCE CURVE OF PUMP KPD 50/32		SUC. 80 mm DEL. 50 mm n = 1450 rpm NOMINAL
	THIS CURVE RELATES TO LIQUID OF SP.GR. = 1.0		

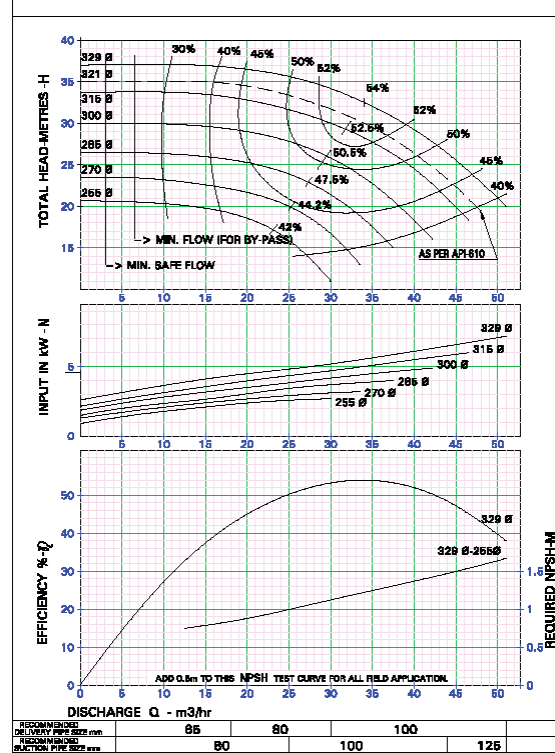

<b>KIRLOSKAR BROTHERS LIMITED</b>	NO. HD13749KA0 0		
	PERFORMANCE CURVE OF PUMP KPD 50/32		SUC. 80 mm DEL. 50 mm n = 2900 rpm NOMINAL
	THIS CURVE RELATES TO LIQUID OF SP.GR. = 1.0		

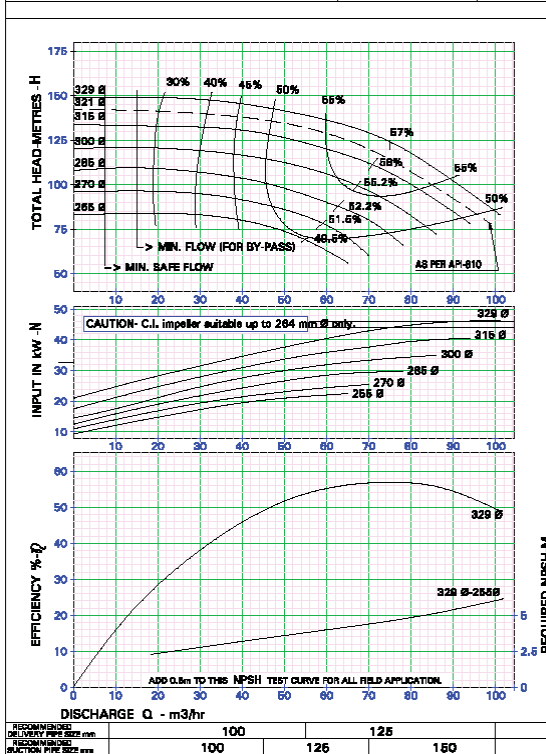

<b>KIRLOSKAR BROTHERS LIMITED</b>	NO. HA13714QB0 0		
	PERFORMANCE CURVE OF PUMP KPD 50/32QF		SUC. 80 mm DEL. 50 mm n = 1450 rpm NOMINAL
	THIS CURVE RELATES TO LIQUID OF SP.GR. = 1.0		

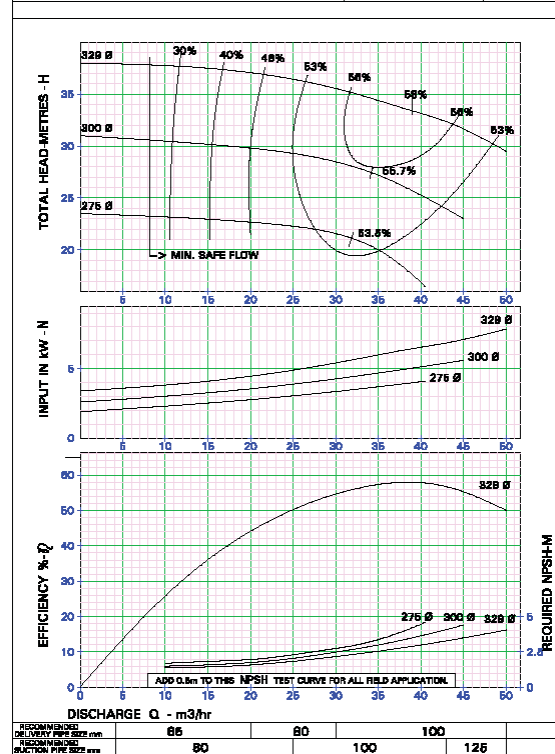

<b>KIRLOSKAR BROTHERS LIMITED</b>	NO. HA13714QAO 0	
PERFORMANCE CURVE OF PUMP KPD 50/32QF	SUC. 80 mm DEL. 50 mm	
THIS CURVE RELATED TO LIQUID OF SP.GR. = 1.0	n = 2800 rpm	
	NOMINAL	

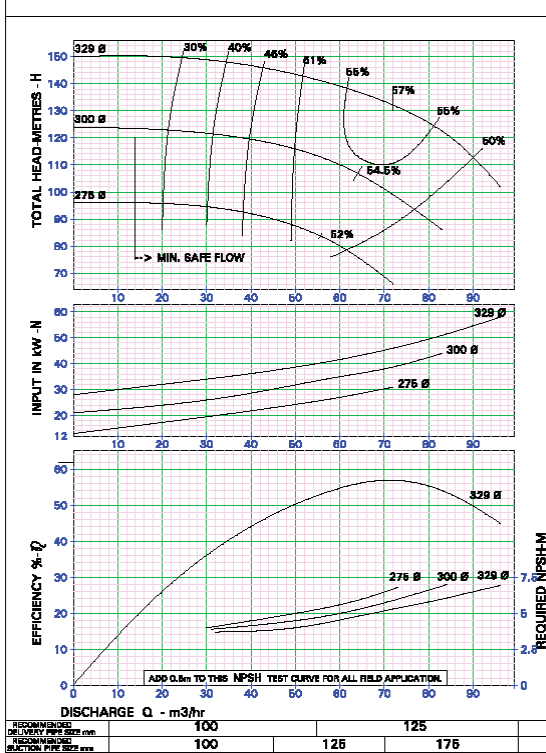

<b>KIRLOSKAR BROTHERS LIMITED</b>	NO. HD13715KB0 0	
PERFORMANCE CURVE OF PUMP KPD 65/13	SUC. 100 mm DEL. 65 mm	
THIS CURVE RELATED TO LIQUID OF SP.GR. = 1.0	n = 1450 rpm	
	NOMINAL	

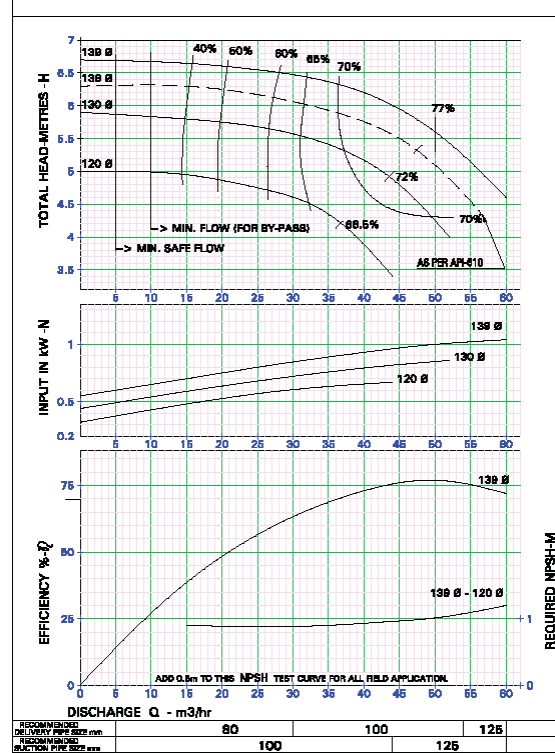

<b>KIRLOSKAR BROTHERS LIMITED</b>	NO. HD13715KA0 0	
PERFORMANCE CURVE OF PUMP KPD 65/13 QF	SUC. 100 mm DEL. 65 mm	
THIS CURVE RELATED TO LIQUID OF SP.GR. = 1.0	n = 2900 rpm	
	NOMINAL	

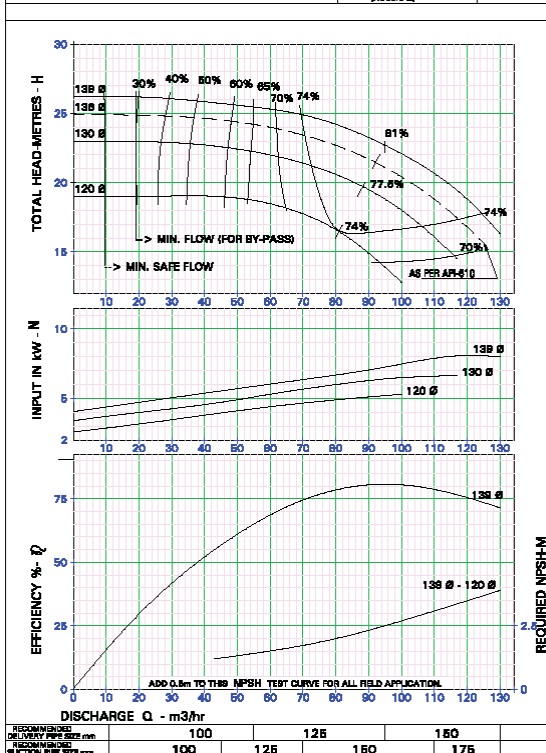

<b>KIRLOSKAR BROTHERS LIMITED</b>	NO. HA13716QB0 0	
PERFORMANCE CURVE OF PUMP KPD 65/13 QF	SUC. 100 mm DEL. 65 mm	
THIS CURVE RELATED TO LIQUID OF SP.GR. = 1.0	n = 1450 rpm	
	NOMINAL	

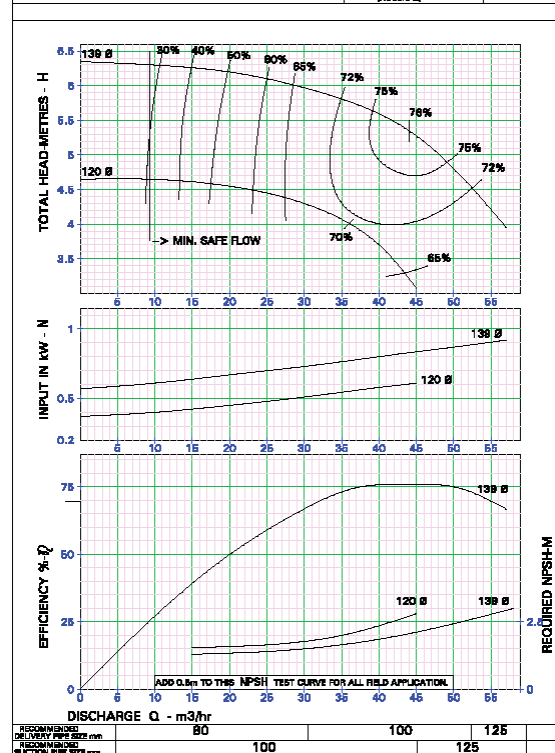

<b>KIRLOSKAR BROTHERS LIMITED</b>	NO. HA137150A0 0	
<b>PERFORMANCE CURVE OF PUMP KPD 65/13QF</b>	SUC. 100 mm DEL. 65 mm	
THIS CURVE RELATES TO LIQUID OF SP.GR. = 1.0	n = 2900 rpm	
	NOMINAL	

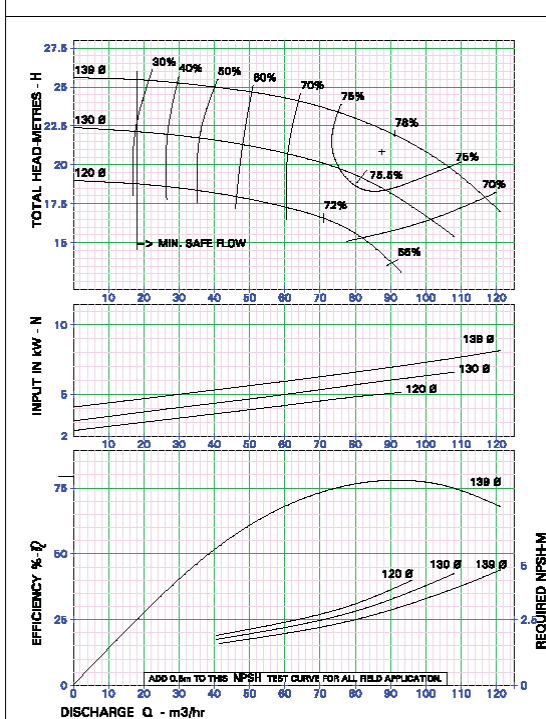

RECOMMENDED DELIVERY PIPE SIZE mm	100	125	150	160
RECOMMENDED SUCTION PIPE SIZE mm	100	125	150	175

<b>KIRLOSKAR BROTHERS LIMITED</b>	NO. HD13750KA0 0	
<b>PERFORMANCE CURVE OF PUMP KPD 65/16</b>	SUC. 100 mm DEL. 65 mm	
THIS CURVE RELATES TO LIQUID OF SP.GR. = 1.0	n = 2900 rpm	
	NOMINAL	

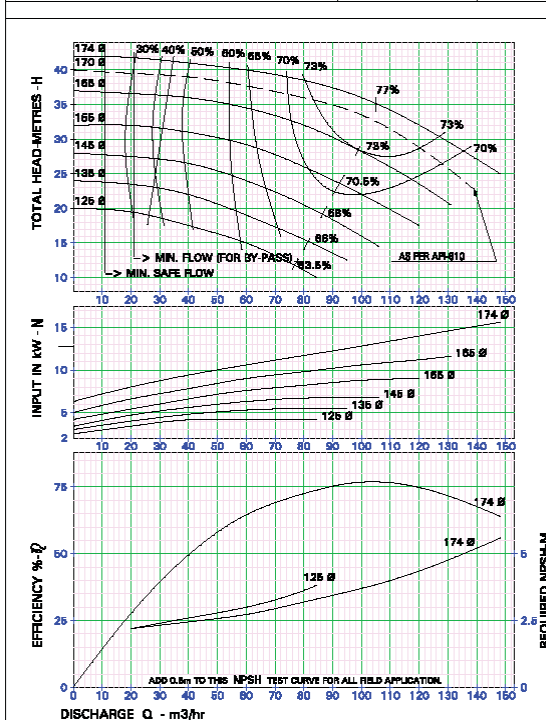

RECOMMENDED DELIVERY PIPE SIZE mm	100	125	150	160
RECOMMENDED SUCTION PIPE SIZE mm	100	125	150	175

<b>KIRLOSKAR BROTHERS LIMITED</b>	NO. HD13716K80 0	
<b>PERFORMANCE CURVE OF PUMP KPD 65/16</b>	SUC. 100 mm DEL. 65 mm	
THIS CURVE RELATES TO LIQUID OF SP.GR. = 1.0	n = 1450 rpm	
	NOMINAL	

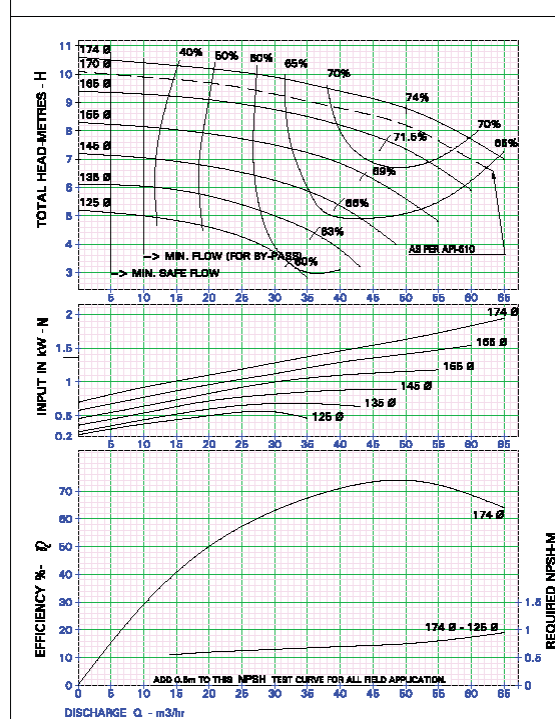

RECOMMENDED DELIVERY PIPE SIZE mm	65	80	100	125
RECOMMENDED SUCTION PIPE SIZE mm	65	80	100	125

<b>KIRLOSKAR BROTHERS LIMITED</b>	NO. HA13716Q80 0	
<b>PERFORMANCE CURVE OF PUMP KPD 65/16 QF</b>	SUC. 100 mm DEL. 65 mm	
THIS CURVE RELATES TO LIQUID OF SP.GR. = 1.0	n = 1450 rpm	
	(NOMINAL)	

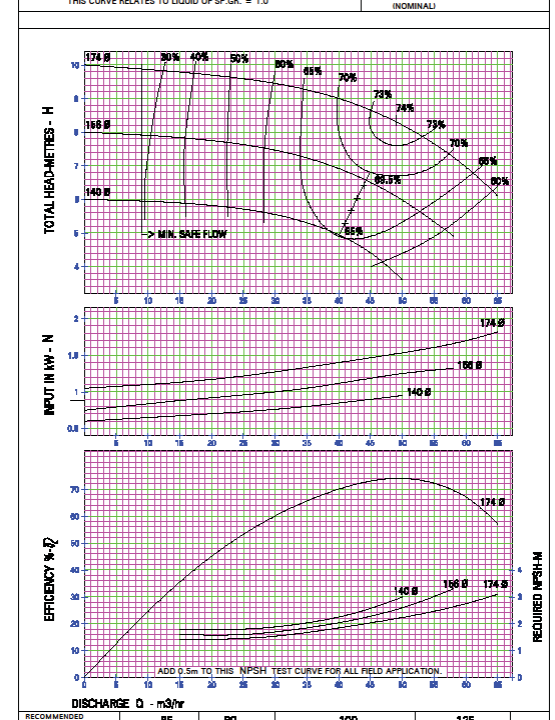

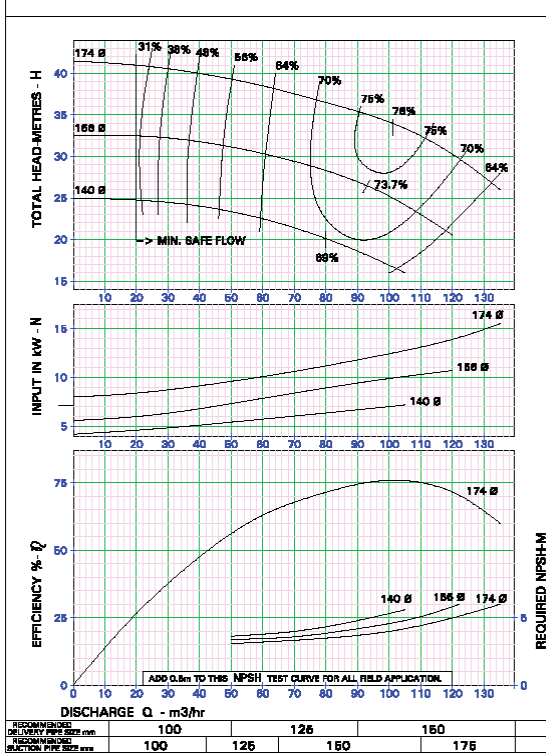

RECOMMENDED DELIVERY PIPE SIZE mm	65	80	100	125
RECOMMENDED SUCTION PIPE SIZE mm	65	80	100	125

<b>KIRLOSKAR BROTHERS LIMITED</b>	NO. HA13718QA0 0	
PERFORMANCE CURVE OF PUMP KPD 65/16QF	SUC. 100mm DEL. 65 mm	
THIS CURVE RELATED TO LIQUID OF SP.GR. = 1.0	n = 2800 rpm	
	NOMINAL	

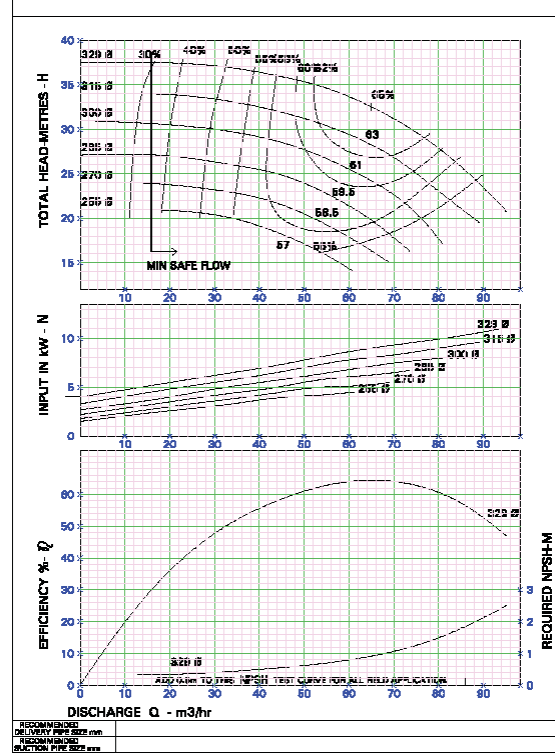

<b>KIRLOSKAR BROTHERS LIMITED</b>	NO. HD13719KB00	
PERFORMANCE CURVE OF PUMP KPD 65/32	SUC. 100mm DEL. 65 mm	
THIS CURVE RELATED TO LIQUID OF SP.GR. = 1.0	n = 1450 rpm	
	NOMINAL	



<b>KIRLOSKAR BROTHERS LIMITED</b>	NO. HD13740KA0 0	
PERFORMANCE CURVE OF PUMP KPD 65/32	SUC. 100mm DEL. 65 mm	
THIS CURVE RELATED TO LIQUID OF SP.GR. = 1.0	n = 2800 rpm	
	NOMINAL	

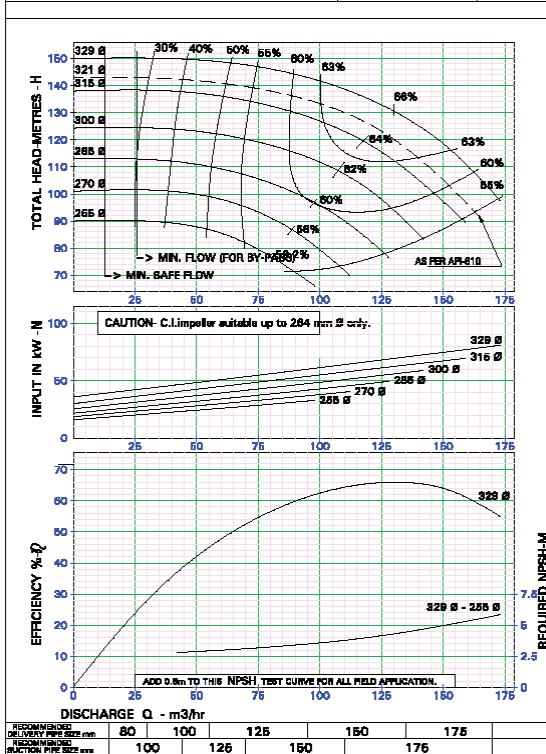

<b>KIRLOSKAR BROTHERS LIMITED</b>	NO. HA13719QB0 0	
PERFORMANCE CURVE OF PUMP KPD 66/32 QF	SUC. 100mm DEL. 65 mm	
THIS CURVE RELATED TO LIQUID OF SP.GR. = 1.0	n = 1450 rpm	
	NOMINAL	

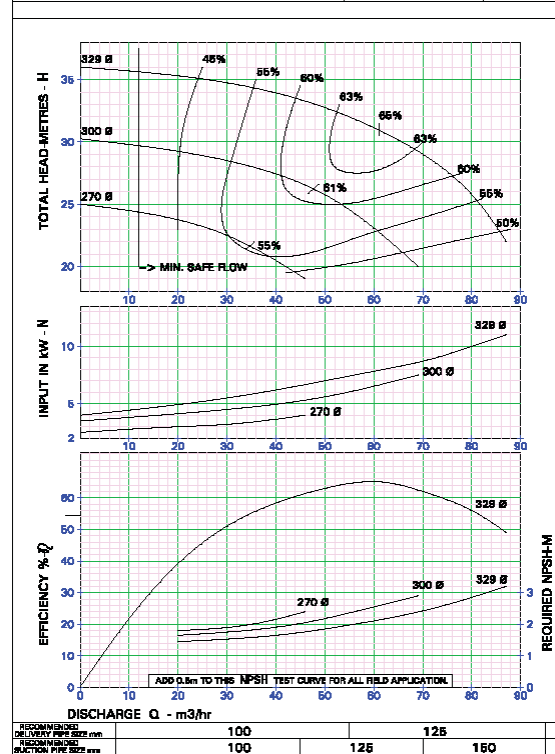

<b>KIRLOSKAR BROTHERS LIMITED</b>	NO. HA13718QA0 0	
PERFORMANCE CURVE OF PUMP KPD 85/32 QF	SUC. 100mm DEL. 65mm n = 2900 rpm (NOMINAL)	
THIS CURVE RELATES TO LIQUID OF SP.GR. = 1.0		

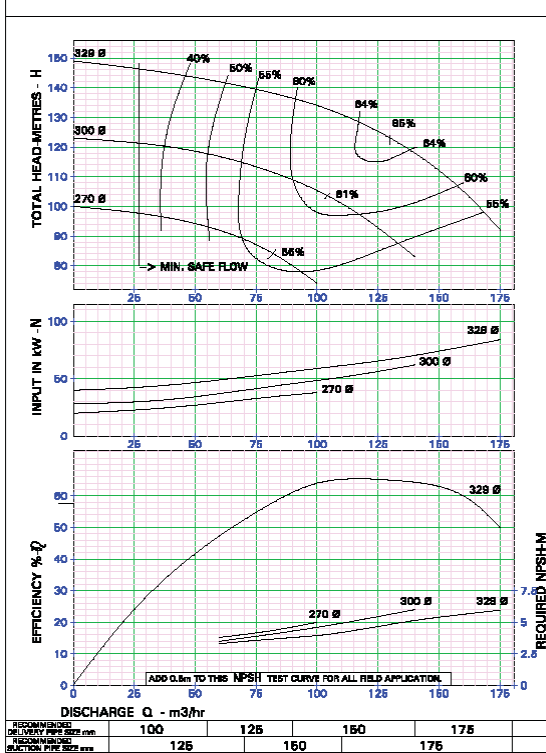

<b>KIRLOSKAR BROTHERS LIMITED</b>	NO. HD13762KB0 0	
PERFORMANCE CURVE OF PUMP KPD 85/43	SUC. 100 mm DEL. 65 mm n = 1450 rpm (NOMINAL)	
THIS CURVE RELATES TO LIQUID OF SP.GR. = 1.0		

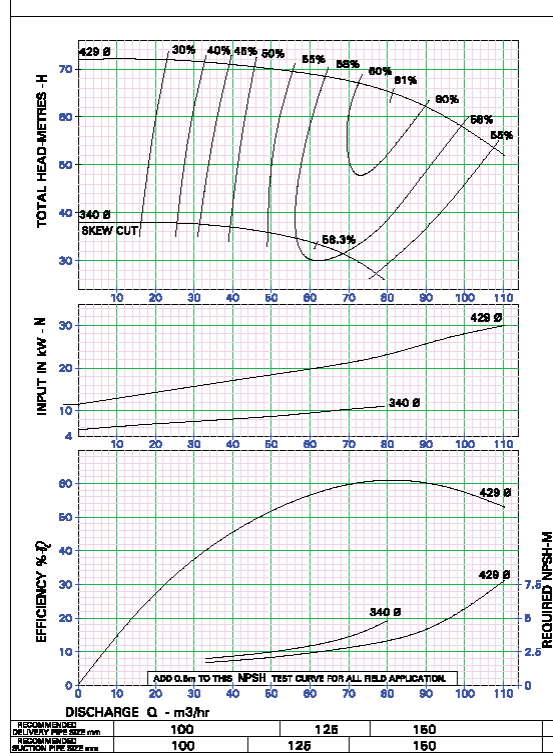

<b>KIRLOSKAR BROTHERS LIMITED</b>	NO. HD13751KA0 0	
PERFORMANCE CURVE OF PUMP KPD 85/20	SUC. 100 mm DEL. 65 mm n = 2500 rpm (NOMINAL)	
THIS CURVE RELATES TO LIQUID OF SP.GR. = 1.0		

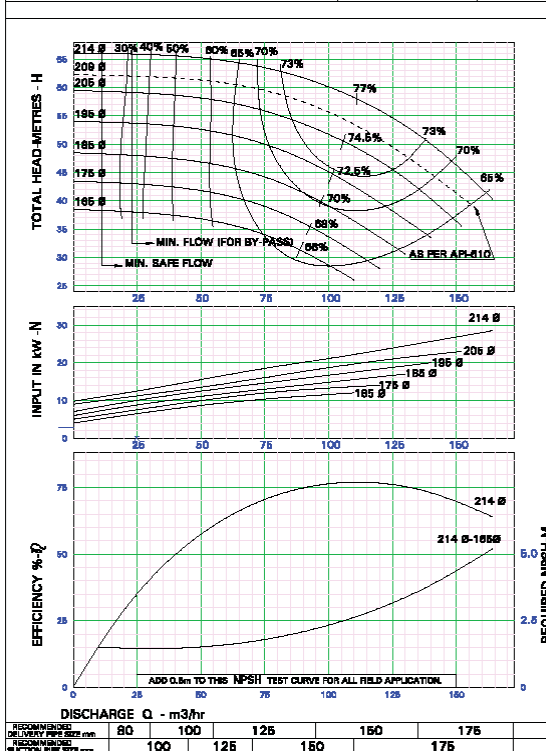

<b>KIRLOSKAR BROTHERS LIMITED</b>	NO. HD13717KB0 0	
PERFORMANCE CURVE OF PUMP KPD 85/20	SUC. 100 mm DEL. 65 mm n = 1460 rpm (NOMINAL)	
THIS CURVE RELATES TO LIQUID OF SP.GR. = 1.0		

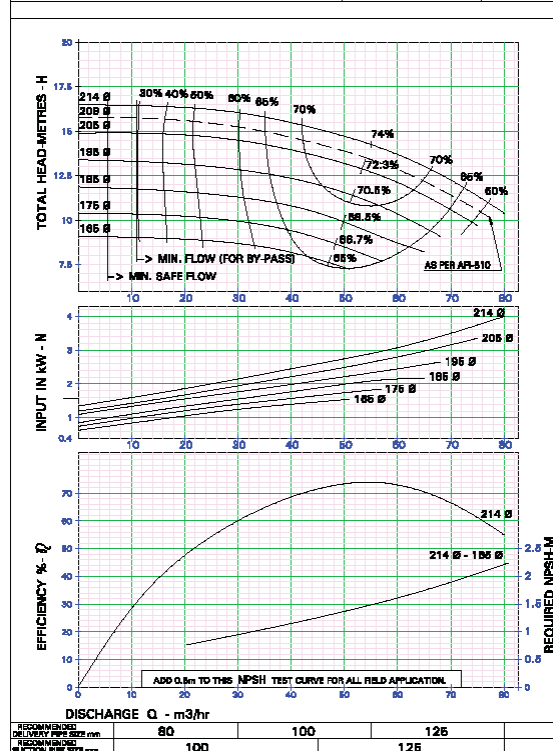

<b>KIRLOSKAR BROTHERS LIMITED</b>	NO. HA13717QBO O	
PERFORMANCE CURVE OF PUMP KPD 65/20 QF	SUC. 100mm DEL. 65mm	
THIS CURVE RELATES TO LIQUID OF SP.GR. = 1.0	n = 1450 rpm	
	NOMINAL	

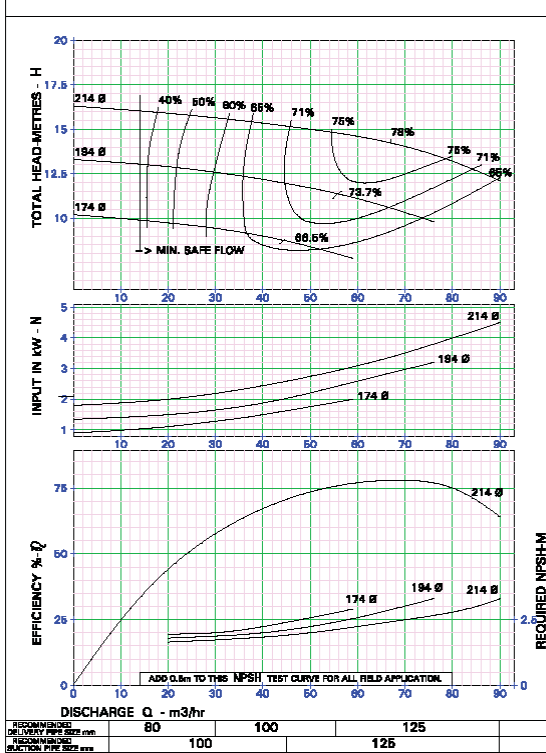

<b>KIRLOSKAR BROTHERS LIMITED</b>	NO. HA13717QAO O	
PERFORMANCE CURVE OF PUMP KPD 65/20 QF	SUC. 100mm DEL. 65mm	
THIS CURVE RELATES TO LIQUID OF SP.GR. = 1.0	n = 2800 rpm	
	NOMINAL	

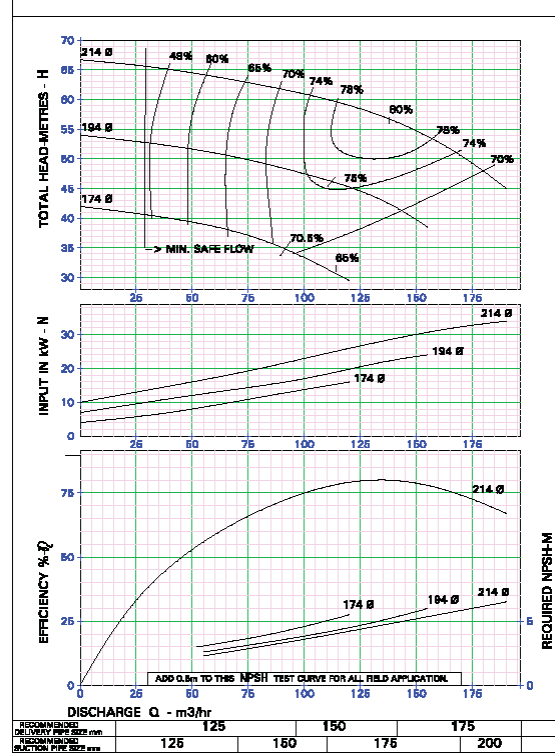

<b>KIRLOSKAR BROTHERS LIMITED</b>	NO. HD13718KBO O	
PERFORMANCE CURVE OF PUMP KPD 65/26	SUC. 100mm DEL. 65mm	
THIS CURVE RELATES TO LIQUID OF SP.GR. = 1.0	n = 1450 rpm	
	NOMINAL	

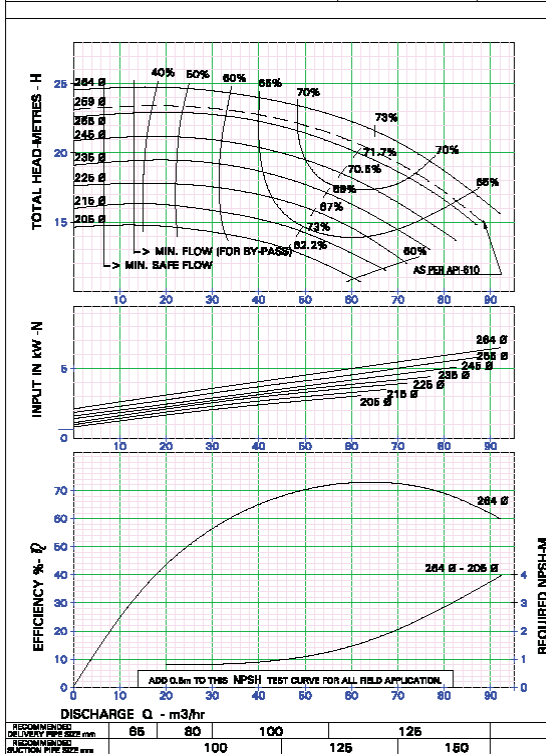

<b>KIRLOSKAR BROTHERS LIMITED</b>	NO. HD13752KAQ O	
PERFORMANCE CURVE OF PUMP KPD 65/26	SUC. 100mm DEL. 65mm	
THIS CURVE RELATES TO LIQUID OF SP.GR. = 1.0	n = 2800 rpm	
	NOMINAL	

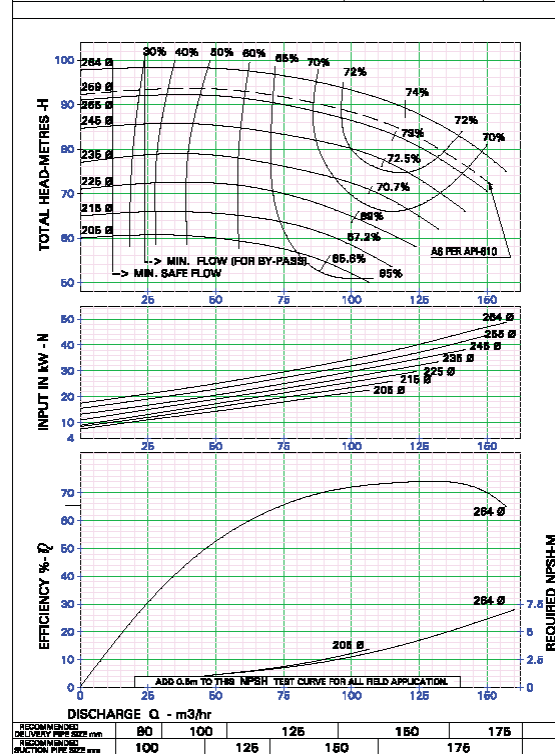

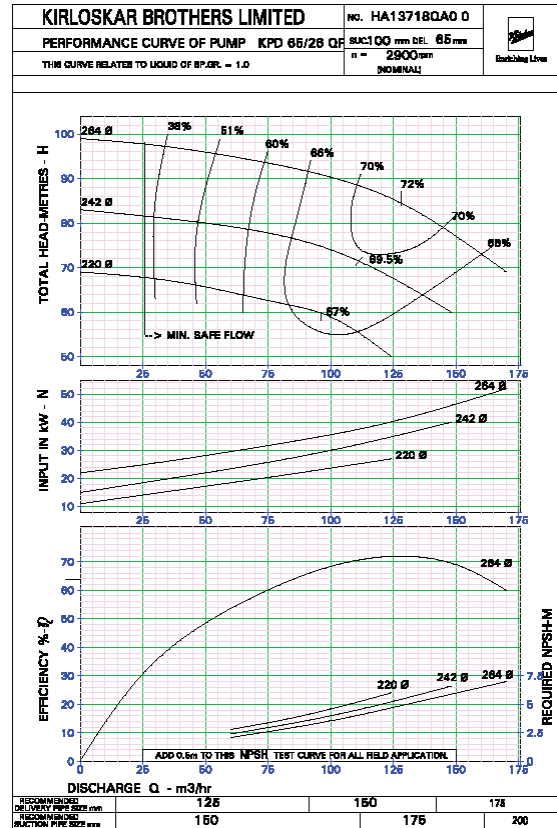
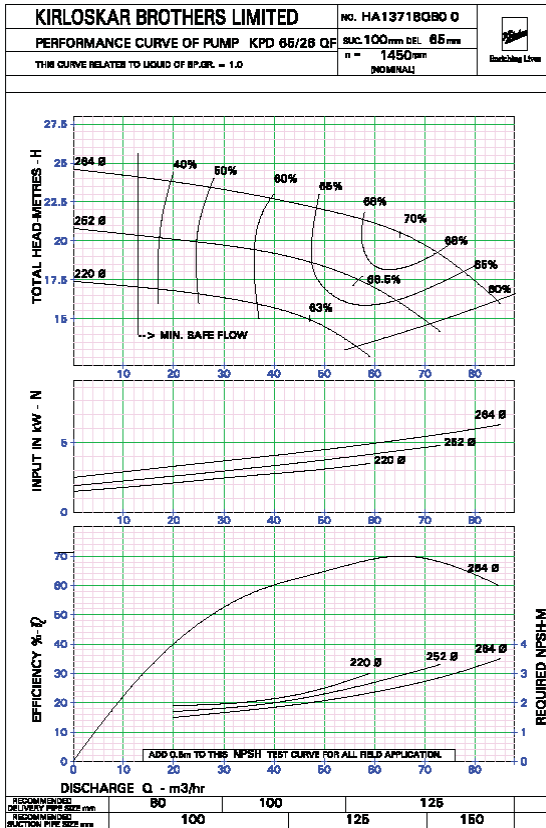
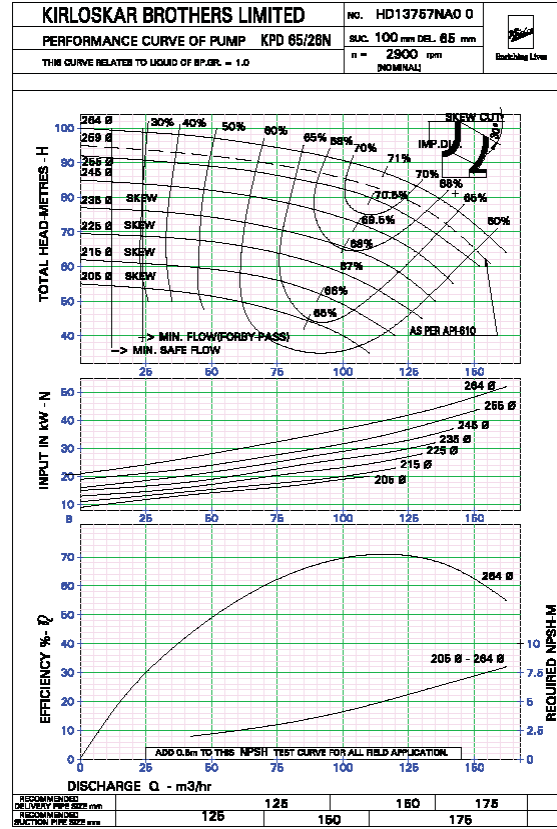
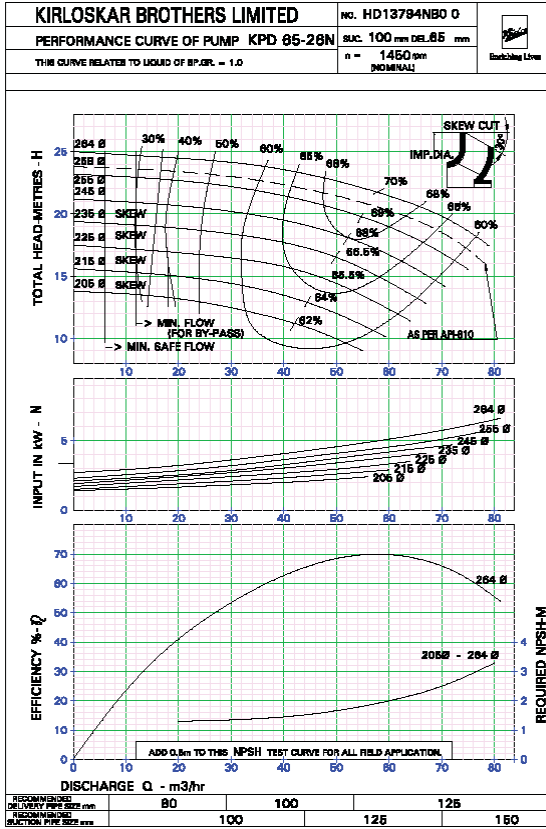

<b>KIRLOSKAR BROTHERS LIMITED</b>	NO. HA13721QAD 0	
PERFORMANCE CURVE OF PUMP KPD 80/20 QF	SUC. 125 mm DEL. 80 mm	
THIS CURVE RELATES TO LIQUID OF SP.GR. = 1.0	n = 2800 rpm	
	NOMINAL	

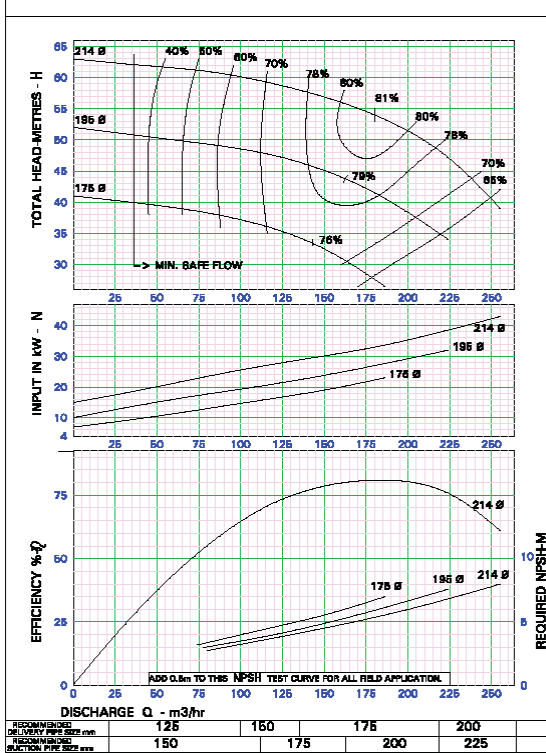

<b>KIRLOSKAR BROTHERS LIMITED</b>	NO. HD13720KB0 0	
PERFORMANCE CURVE OF PUMP KPD 80/16	SUC. 125 mm DEL. 80 mm	
THIS CURVE RELATES TO LIQUID OF SP.GR. = 1.0	n = 1450 rpm	
	NOMINAL	

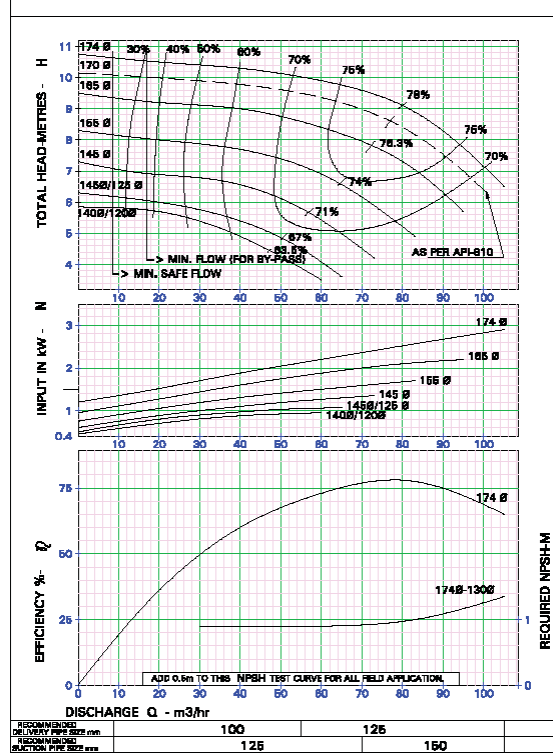

<b>KIRLOSKAR BROTHERS LIMITED</b>	NO. HD13753KA0 0	
PERFORMANCE CURVE OF PUMP KPD 80/16	SUC. 125 mm DEL. 80 mm	
THIS CURVE RELATES TO LIQUID OF SP.GR. = 1.0	n = 2900 rpm	
	NOMINAL	

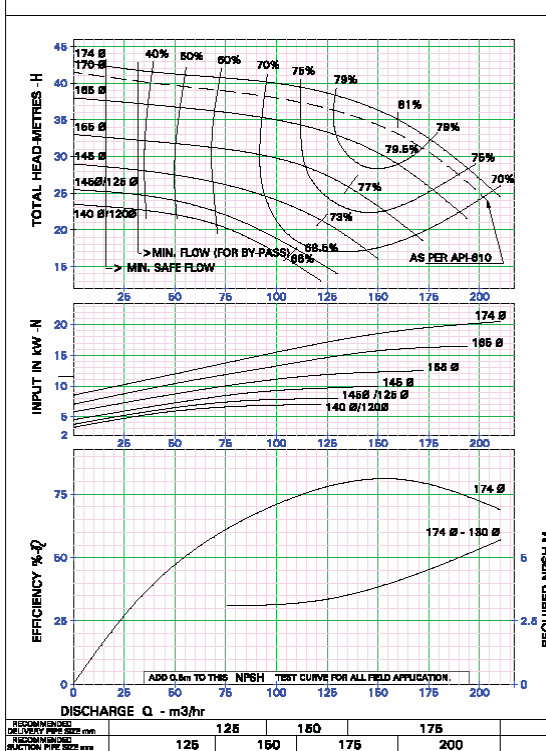

<b>KIRLOSKAR BROTHERS LIMITED</b>	NO. HA13720QB0 0	
PERFORMANCE CURVE OF PUMP KPD 80/16 QF	SUC. 125 mm DEL. 80 mm	
THIS CURVE RELATES TO LIQUID OF SP.GR. = 1.0	n = 1450 rpm	
	NOMINAL	

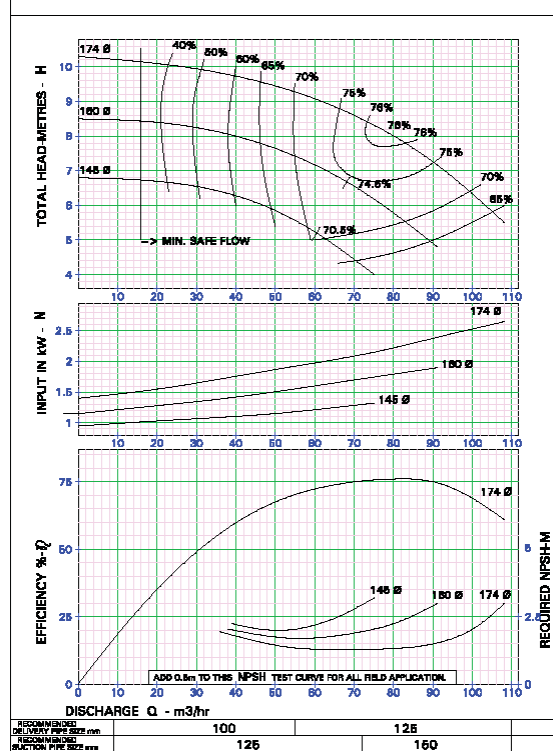

<b>KIRLOSKAR BROTHERS LIMITED</b>	NO. HA13720QA0 0	
PERFORMANCE CURVE OF PUMP KPD 80/16 QF	SUC. 125mm DEL. 80mm	
THIS CURVE RELATES TO LIQUID OF SP.GR. = 1.0	n = 2900 rpm	
	NOMINAL	

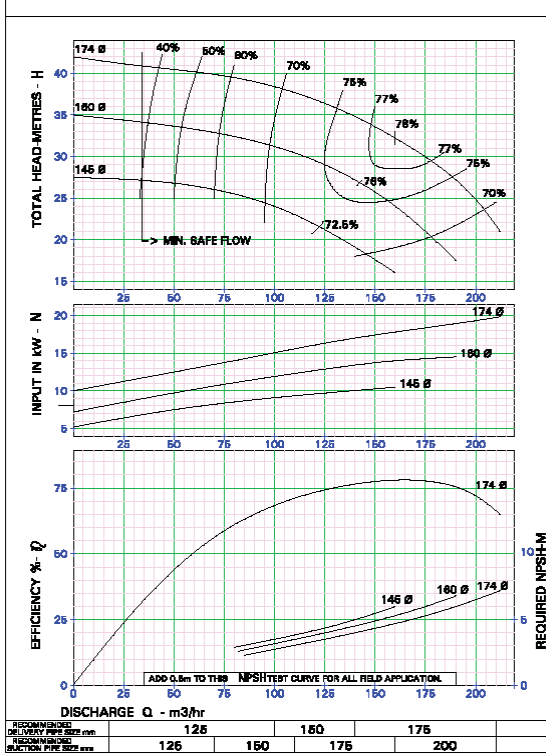

<b>KIRLOSKAR BROTHERS LIMITED</b>	NO. HD13721KB0 0	
PERFORMANCE CURVE OF PUMP KPD 80-20	SUC. 125mm DEL. 80mm	
THIS CURVE RELATES TO LIQUID OF SP.GR. = 1.0	n = 1450 rpm	
	NOMINAL	

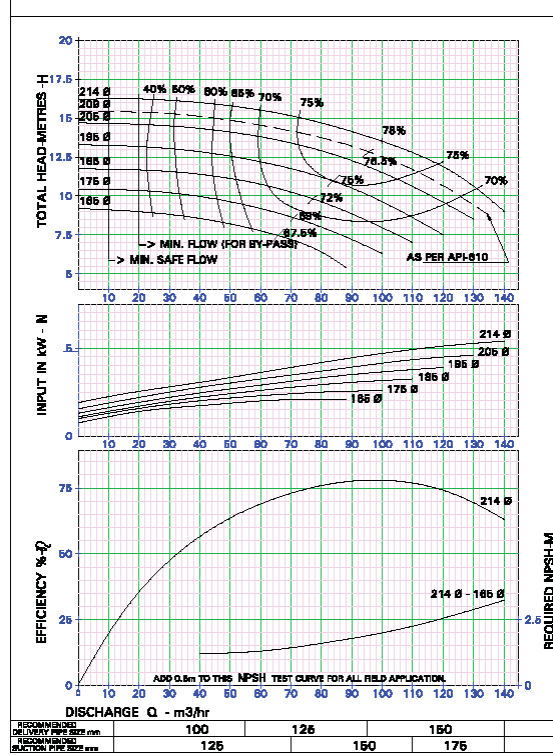

<b>KIRLOSKAR BROTHERS LIMITED</b>	NO. HD13754KA0 0	
PERFORMANCE CURVE OF PUMP KPD 80-20	SUC. 125mm DEL. 80mm	
THIS CURVE RELATES TO LIQUID OF SP.GR. = 1.0	n = 2900 rpm	
	NOMINAL	

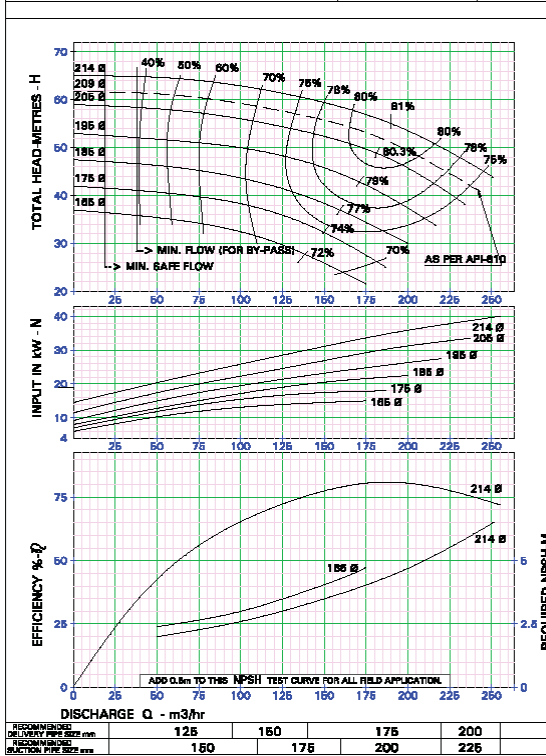

<b>KIRLOSKAR BROTHERS LIMITED</b>	NO. HA13721QB0 0	
PERFORMANCE CURVE OF PUMP KPD 80/20 QF	SUC. 125mm DEL. 80mm	
THIS CURVE RELATES TO LIQUID OF SP.GR. = 1.0	n = 1450 rpm	
	NOMINAL	

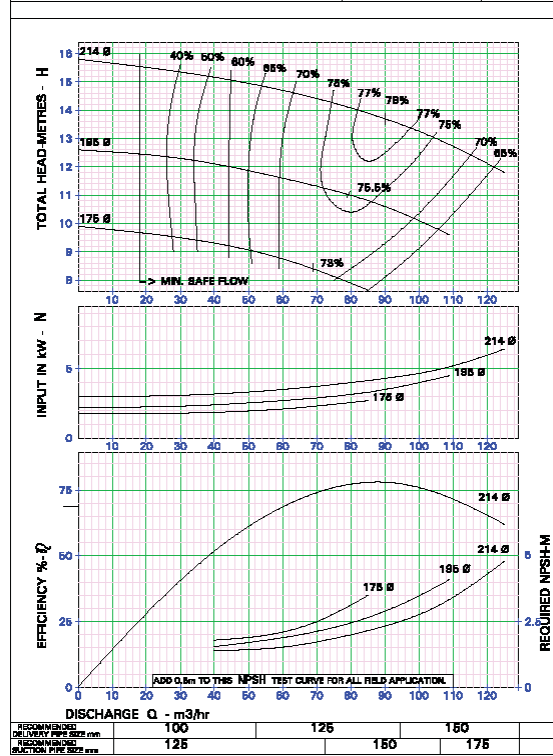

<b>KIRLOSKAR BROTHERS LIMITED</b>	NO. HA13723QA00
PERFORMANCE CURVE OF PUMP KPD 80/32QF	SUC. 125 mm DEL. 80 mm
THIS CURVE RELATES TO LIQUID OF SP.GR. = 1.0	n = 2950 rpm NOMINAL

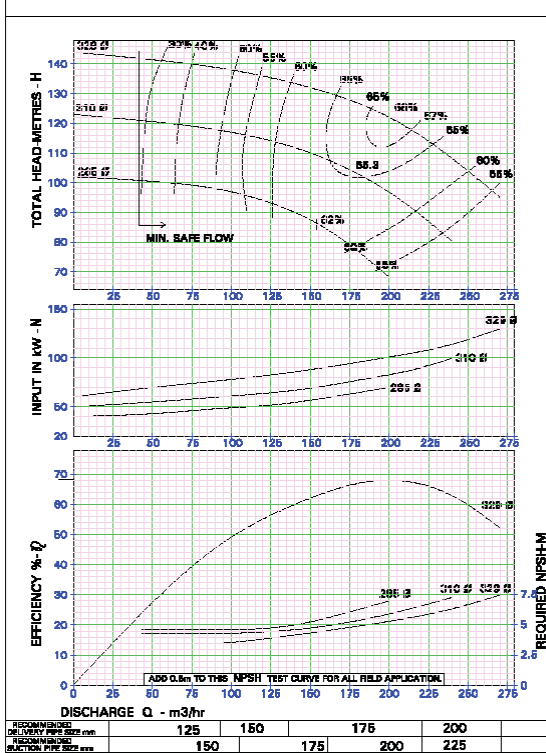

<b>KIRLOSKAR BROTHERS LIMITED</b>	NO. HD19722KB0 0
PERFORMANCE CURVE OF PUMP KPD 80/26	SUC. 125 mm DEL. 80 mm
THIS CURVE RELATES TO LIQUID OF SP.GR. = 1.0	n = 1450 rpm NOMINAL

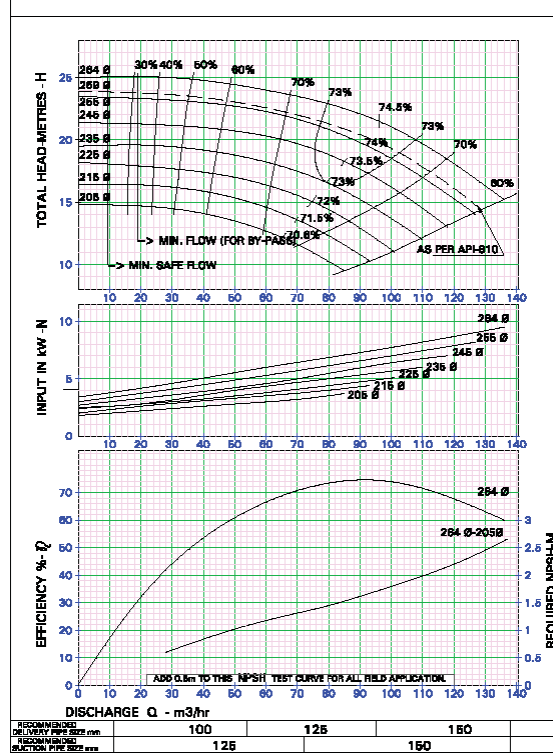

<b>KIRLOSKAR BROTHERS LIMITED</b>	NO. HD13758KA0 0
PERFORMANCE CURVE OF PUMP KPD 80/26	SUC. 125 mm DEL. 80 mm
THIS CURVE RELATES TO LIQUID OF SP.GR. = 1.0	n = 2900 rpm NOMINAL

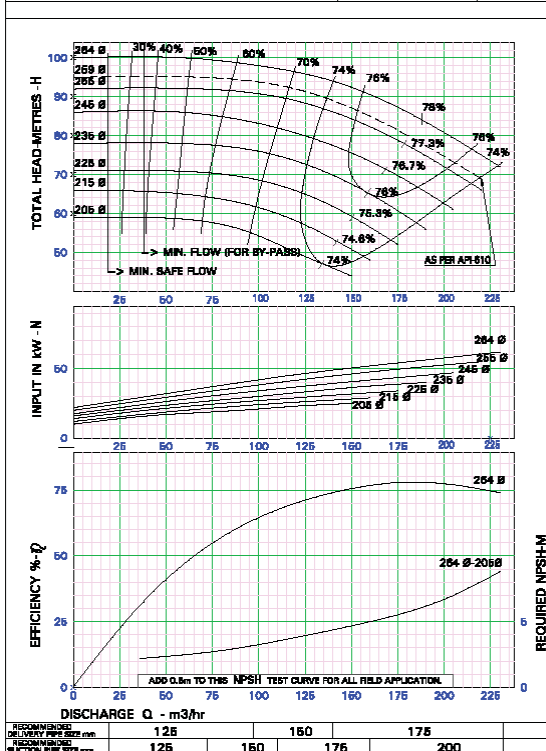

<b>KIRLOSKAR BROTHERS LIMITED</b>	NO. HA13722QB0 0
PERFORMANCE CURVE OF PUMP KPD 80/28QF	SUC. 125 mm DEL. 80 mm
THIS CURVE RELATES TO LIQUID OF SP.GR. = 1.0	n = 1450 rpm NOMINAL

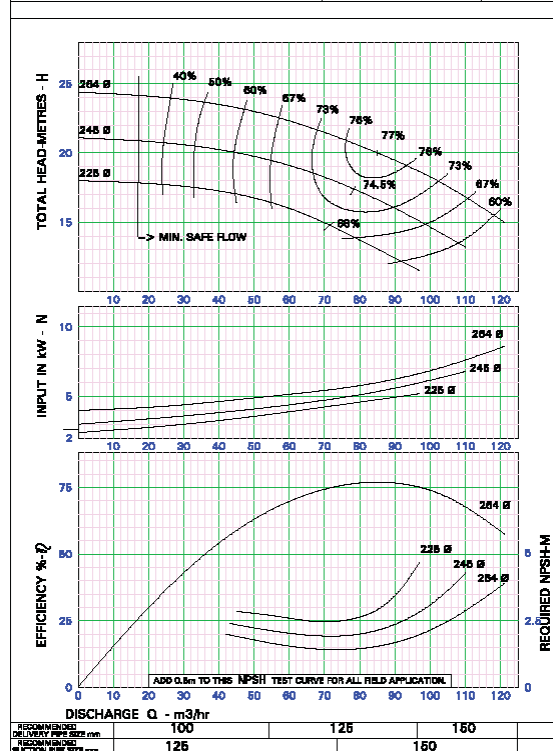

<b>KIRLOSKAR BROTHERS LIMITED</b>	NO. HA13722QA0 0	
PERFORMANCE CURVE OF PUMP KPD 80/28 QF	SUC.125mm DEL.80mm	
THIS CURVE RELATES TO LIQUID OF SP.GR. = 1.0	n = 2900rpm	
	NOMINAL	

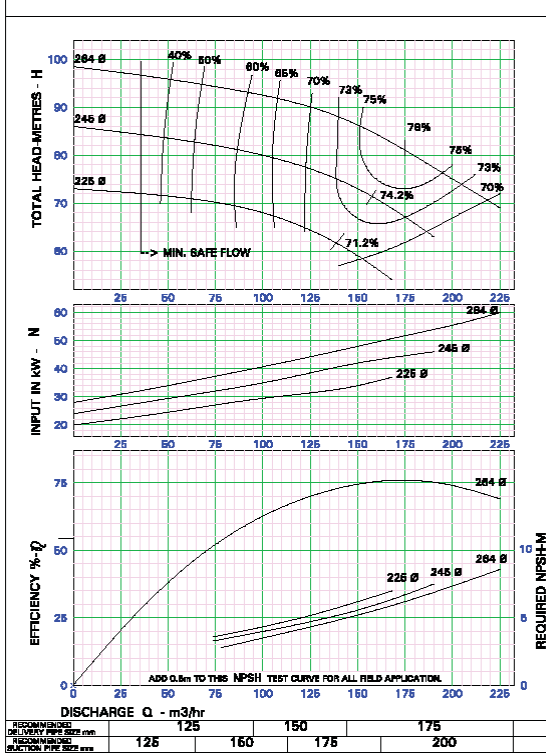

<b>KIRLOSKAR BROTHERS LIMITED</b>	NO. HD13723KB0 0	
PERFORMANCE CURVE OF PUMP KPD 80/32	SUC.125mm DEL.80mm	
THIS CURVE RELATES TO LIQUID OF SP.GR. = 1.0	n = 1450rpm	
	NOMINAL	

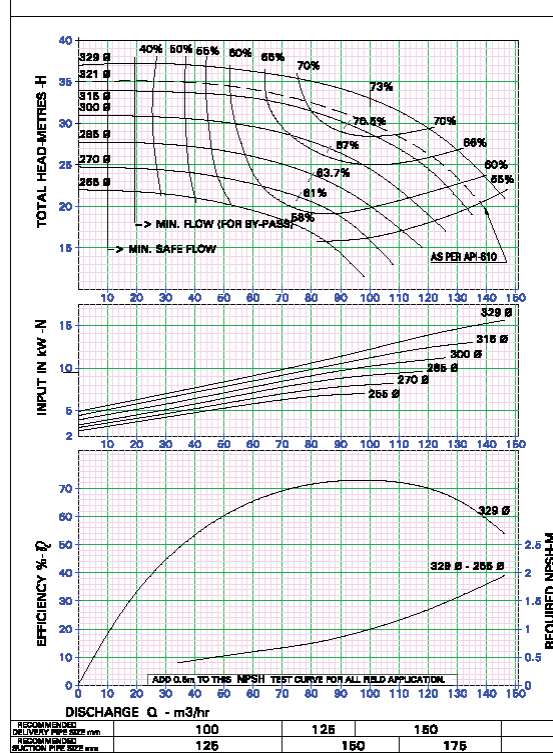

<b>KIRLOSKAR BROTHERS LIMITED</b>	NO. HD13723KA0 0	
PERFORMANCE CURVE OF PUMP KPD 80/32	SUC.125mm DEL.80mm	
THIS CURVE RELATES TO LIQUID OF SP.GR. = 1.0	n = 2950rpm	
	NOMINAL	

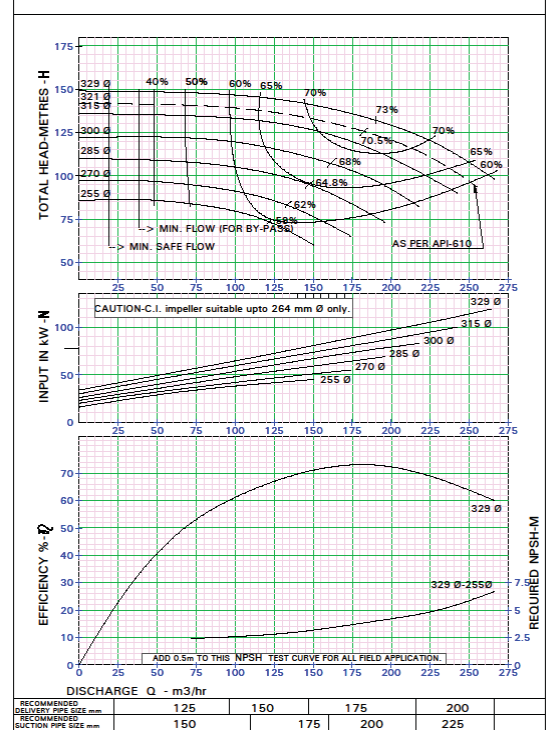

<b>KIRLOSKAR BROTHERS LIMITED</b>	NO. HA13723QB0 0	
PERFORMANCE CURVE OF PUMP KPD 80/32QF	SUC.125mm DEL.80mm	
THIS CURVE RELATES TO LIQUID OF SP.GR. = 1.0	n = 1450rpm	
	NOMINAL	

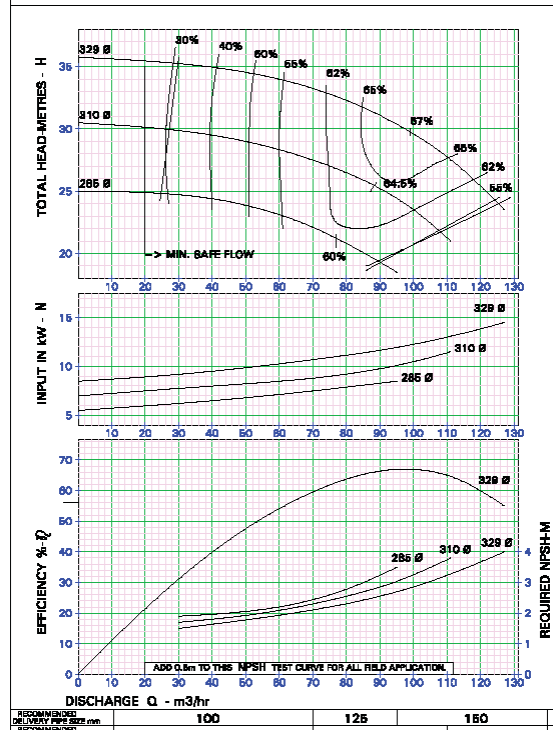

**KIRLOSKAR BROTHERS LIMITED** NO. HD13768KA0-0  
**PERFORMANCE CURVE OF PUMP KPD 80/40DV** SUC. 125mm DEL. 80 mm  
 THIS CURVE RELATES TO LIQUID OF SP.GR. = 1.0 n = 2900 rpm (NOMINAL)

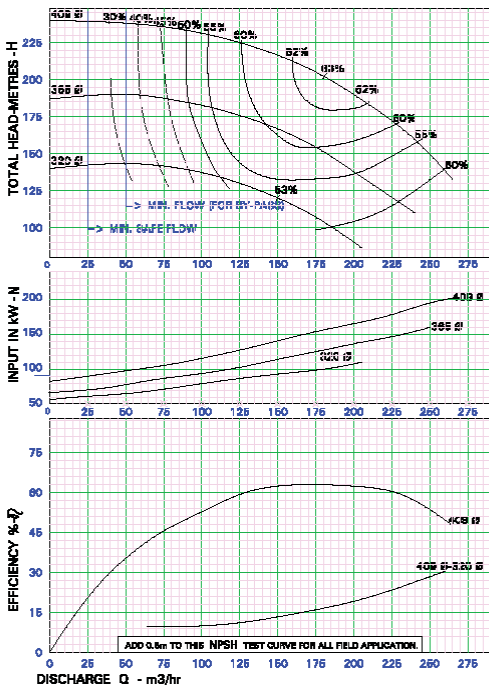

RECOMMENDED DELIVERY PIPE SIZE mm	100	125	150	175	200
RECOMMENDED SUCTION PIPE SIZE mm	125	150	175	200	225

**KIRLOSKAR BROTHERS LIMITED** NO. HD13724KB0 0  
**PERFORMANCE CURVE OF PUMP KPD 80/40** SUC. 125mm DEL. 80 mm  
 THIS CURVE RELATES TO LIQUID OF SP.GR. = 1.0 n = 1450 rpm (NOMINAL)

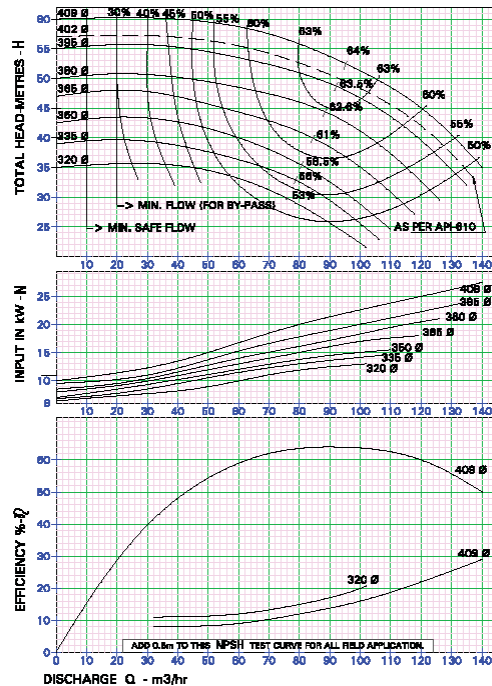

RECOMMENDED DELIVERY PIPE SIZE mm	100	125	150	175
RECOMMENDED SUCTION PIPE SIZE mm	125	150	175	

**KIRLOSKAR BROTHERS LIMITED** NO. HD13768NB0 0  
**PERFORMANCE CURVE OF PUMP KPD 80/40N** SUC. 125 mm DEL. 80 mm  
 THIS CURVE RELATES TO LIQUID OF SP.GR. = 1.0 n = 1450 rpm (NOMINAL)

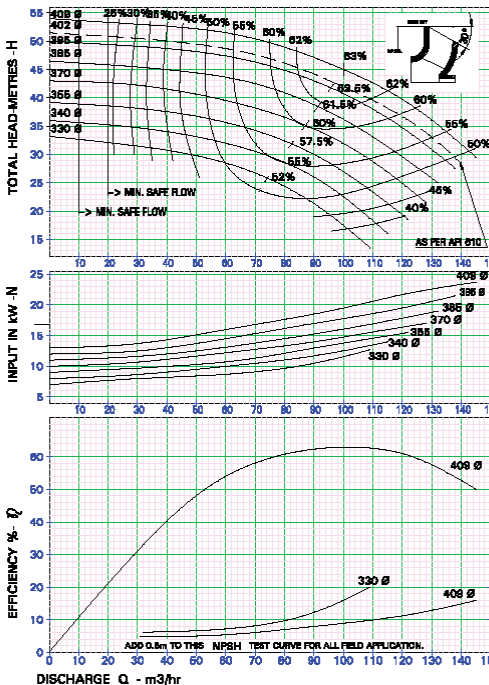

RECOMMENDED DELIVERY PIPE SIZE mm	100	125	150	175
RECOMMENDED SUCTION PIPE SIZE mm	125	150	175	

**KIRLOSKAR BROTHERS LIMITED** NO. HA13724QB0 0  
**PERFORMANCE CURVE OF PUMP KPD 80/40 QF** SUC. 125mm DEL. 80mm  
 THIS CURVE RELATES TO LIQUID OF SP.GR. = 1.0 n = 1450 rpm (NOMINAL)

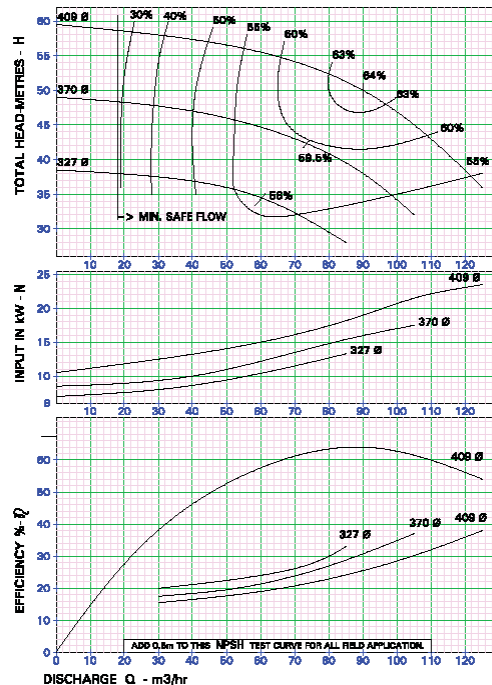

RECOMMENDED DELIVERY PIPE SIZE mm	100	125	150	175
RECOMMENDED SUCTION PIPE SIZE mm	125	150	175	

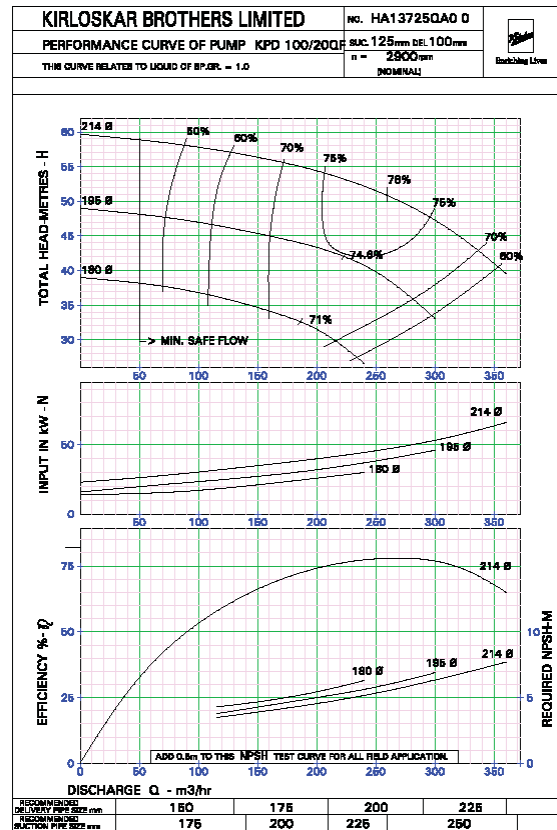
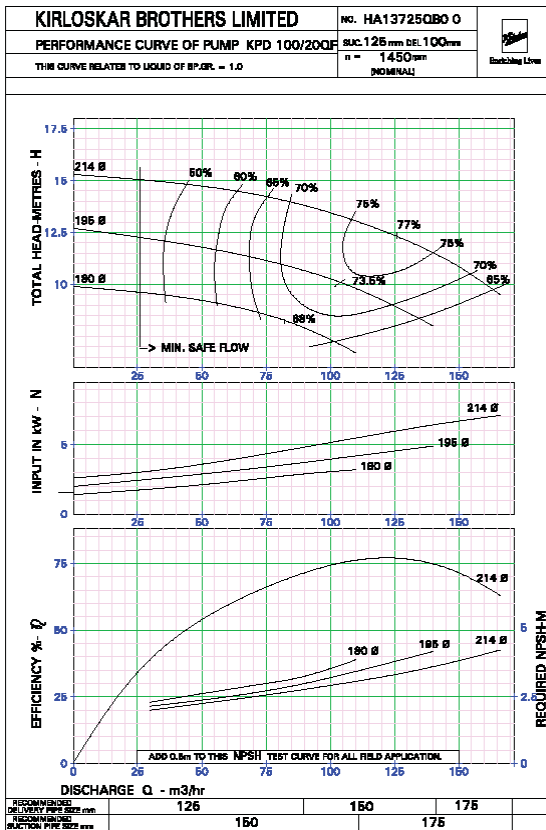
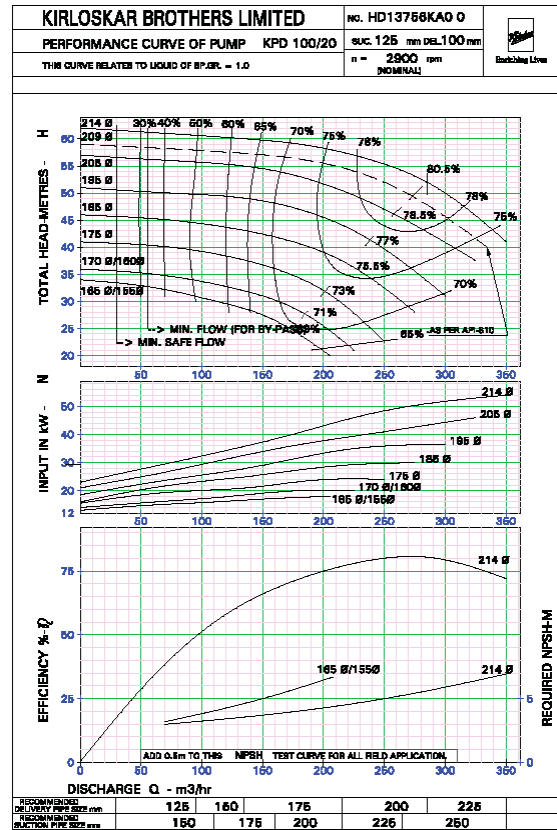
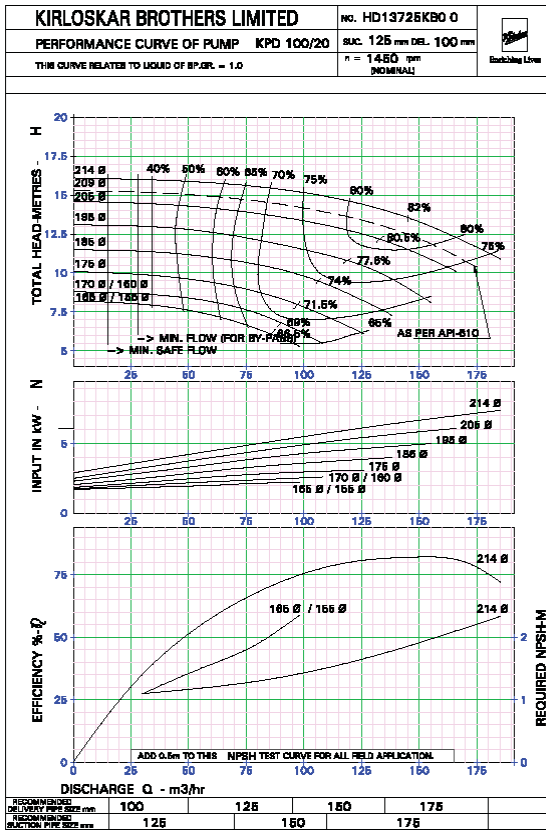

**KIRLOSKAR BROTHERS LIMITED** NO. HD13728KB0 0  
**PERFORMANCE CURVE OF PUMP KPD 100/26** SUC. 125 mm DEL. 100mm  
 n = 1450 rpm  
 THIS CURVE RELATED TO LIQUID OF SP.GR. = 1.0  
 NOMINAL

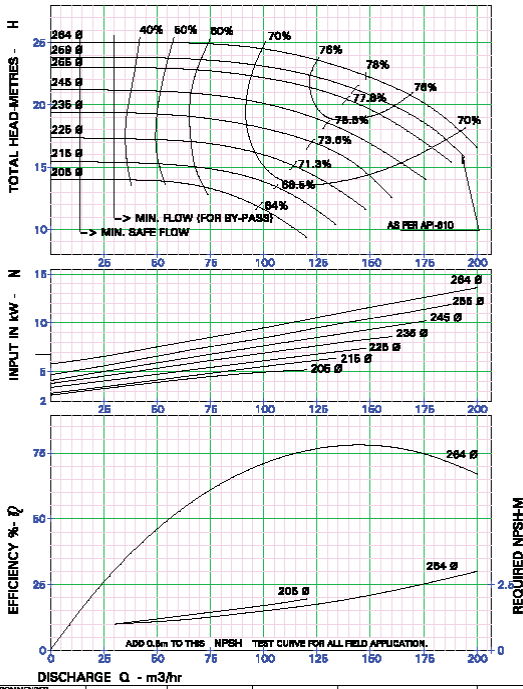

RECOMMENDED DELIVERY PIPE SIZE mm	100	125	150	175	200
RECOMMENDED SUCTION PIPE SIZE mm	125	160	175	200	

**KIRLOSKAR BROTHERS LIMITED** NO. HD13728KA0 0  
**PERFORMANCE CURVE OF PUMP KPD 100/26** SUC. 125 mm DEL. 100mm  
 n = 2900 rpm  
 THIS CURVE RELATED TO LIQUID OF SP.GR. = 1.0  
 NOMINAL

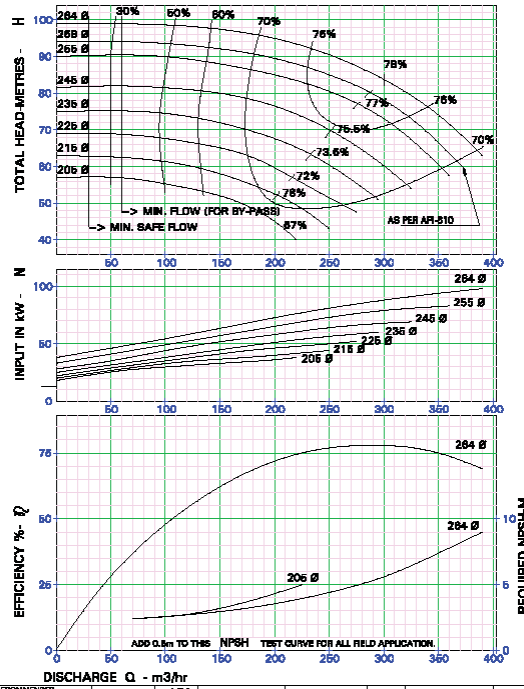

RECOMMENDED DELIVERY PIPE SIZE mm	126	150	175	200	225	250
RECOMMENDED SUCTION PIPE SIZE mm	125	160	175	200	225	300

**KIRLOSKAR BROTHERS LIMITED** NO. HA13728QB0 0  
**PERFORMANCE CURVE OF PUMP KPD 100/26 QF** SUC. 125 mm DEL. 100mm  
 n = 1450 rpm  
 THIS CURVE RELATED TO LIQUID OF SP.GR. = 1.0  
 NOMINAL

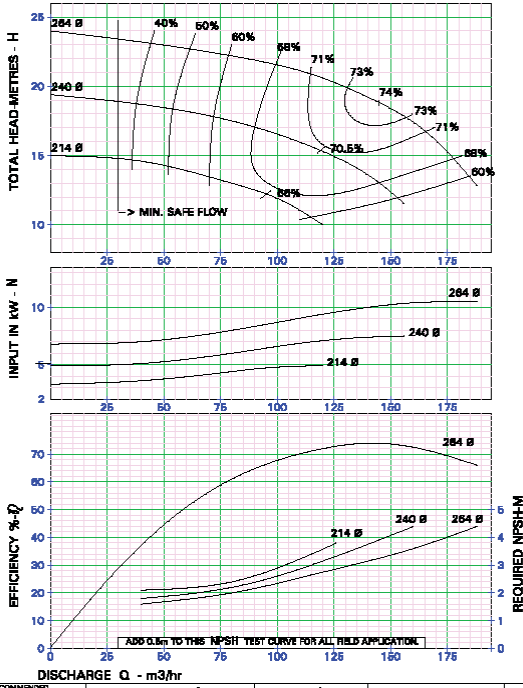

RECOMMENDED DELIVERY PIPE SIZE mm	125	150	175
RECOMMENDED SUCTION PIPE SIZE mm	150	175	200

**KIRLOSKAR BROTHERS LIMITED** NO. HA13728QA0 0  
**PERFORMANCE CURVE OF PUMP KPD 100/26 QF** SUC. 125 mm DEL. 100mm  
 n = 2900 rpm  
 THIS CURVE RELATED TO LIQUID OF SP.GR. = 1.0  
 NOMINAL

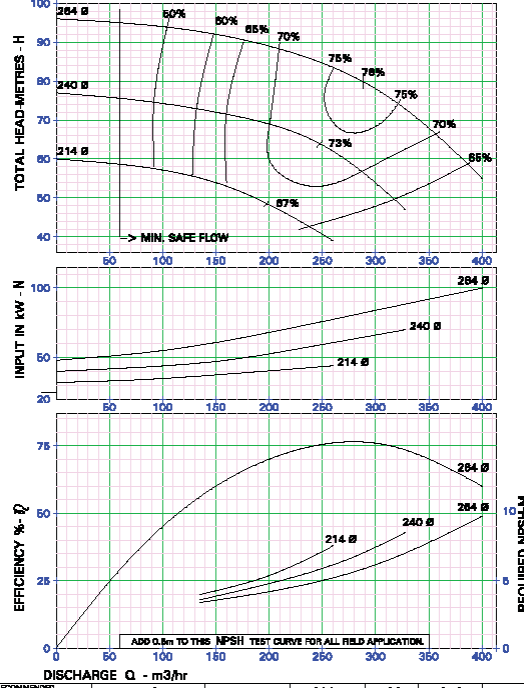

RECOMMENDED DELIVERY PIPE SIZE mm	150	175	200	225	250
RECOMMENDED SUCTION PIPE SIZE mm	160	175	200	225	300

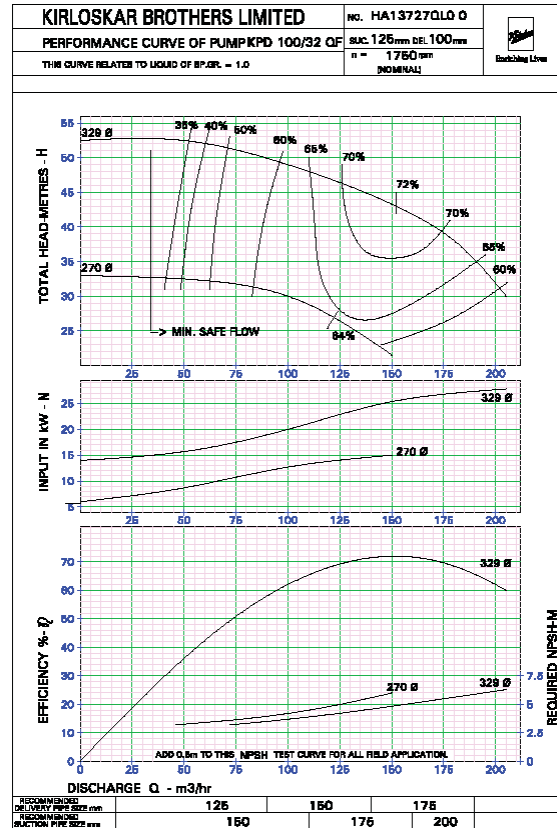
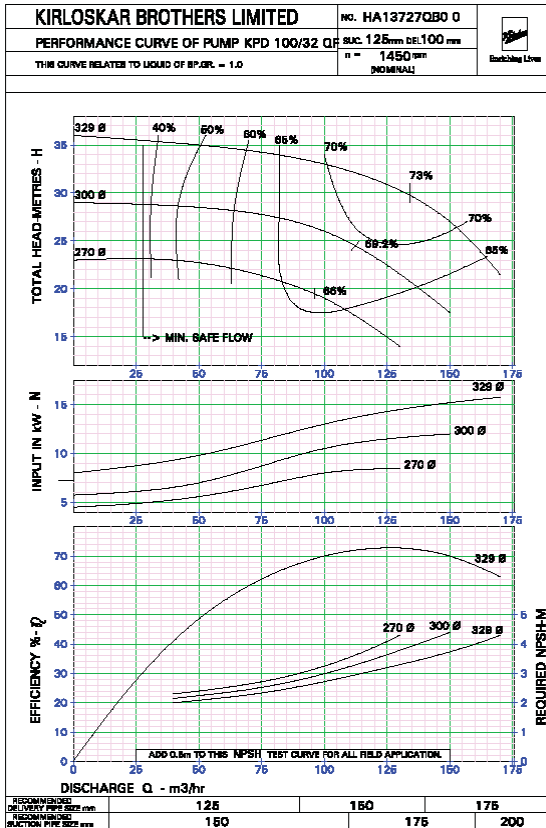
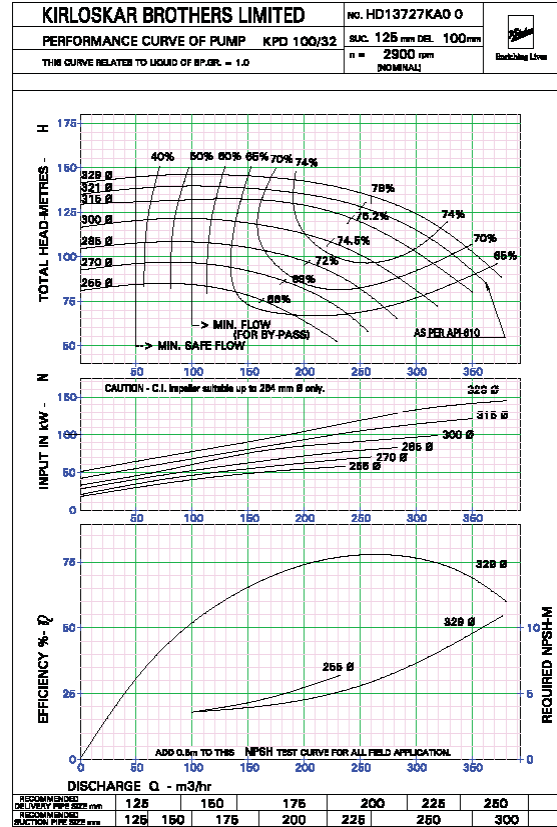
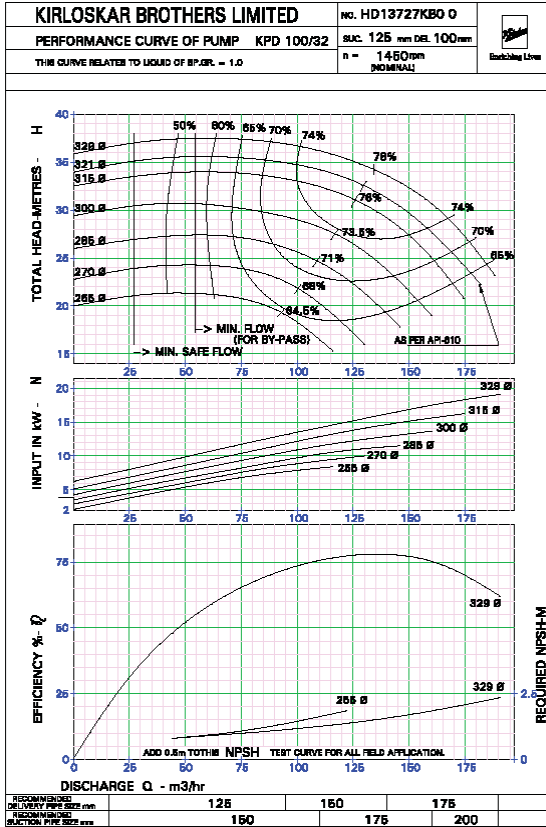

<b>KIRLOSKAR BROTHERS LIMITED</b>	NO. HA13727QA0 0	
PERFORMANCE CURVE OF PUMP KPD 100/32 QF	SUC. 125mm DEL. 100mm n = 2800 rpm	
THIS CURVE RELATED TO LIQUID OF SP.GR. = 1.0	NOMINAL	

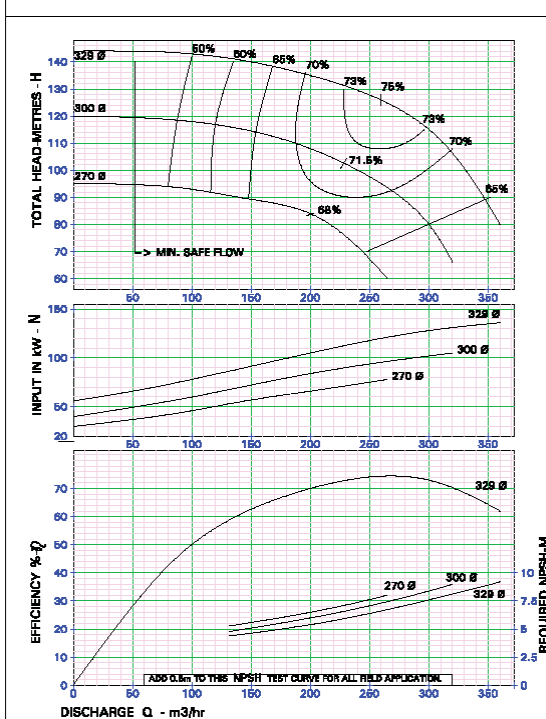

<b>KIRLOSKAR BROTHERS LIMITED</b>	NO. HD13728KB0 0	
PERFORMANCE CURVE OF PUMP KPD 100/40	SUC. 125mm DEL. 100mm n = 1450 rpm	
THIS CURVE RELATED TO LIQUID OF SP.GR. = 1.0	NOMINAL	

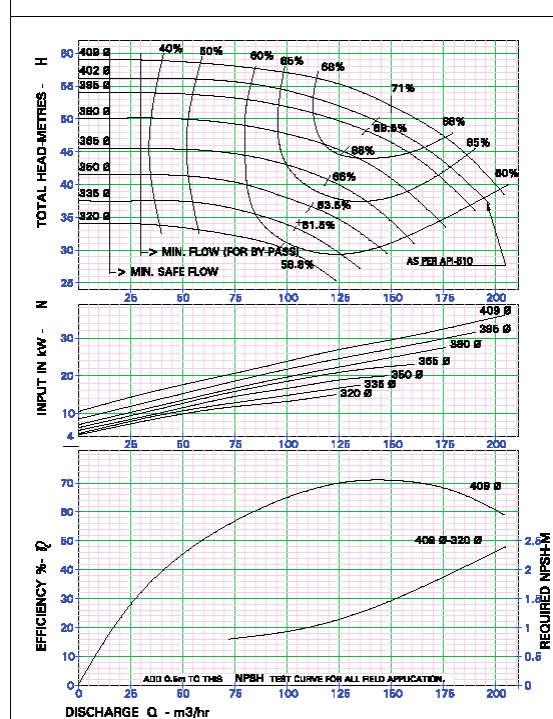

<b>KIRLOSKAR BROTHERS LIMITED</b>	NO. HA13728QB0 0	
PERFORMANCE CURVE OF PUMP KPD 100/40 QF	SUC. 125mm DEL. 100mm n = 1450 rpm	
THIS CURVE RELATED TO LIQUID OF SP.GR. = 1.0	NOMINAL	

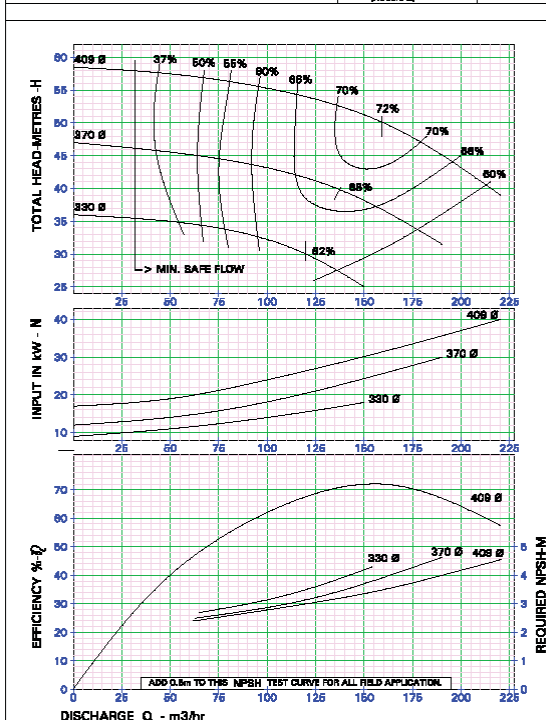

<b>KIRLOSKAR BROTHERS LIMITED</b>	NO. HD13728KB0 0	
PERFORMANCE CURVE OF PUMP KPD 126/26	SUC. 150mm DEL. 125mm n = 1450 rpm	
THIS CURVE RELATED TO LIQUID OF SP.GR. = 1.0	NOMINAL	

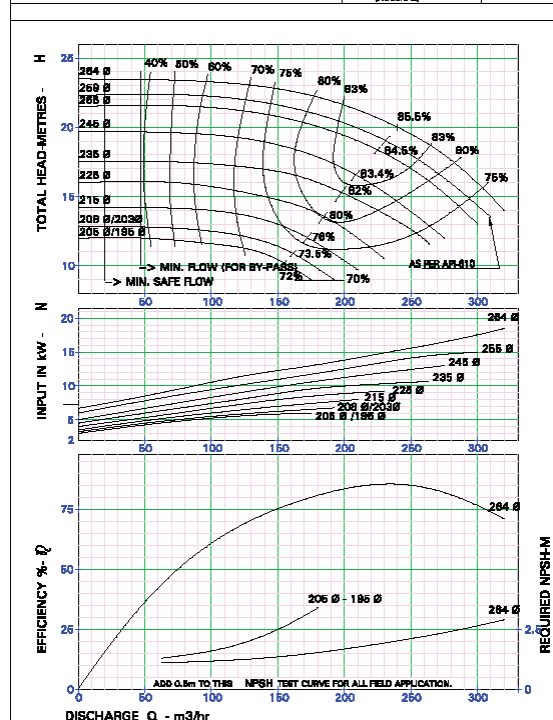

<b>KIRLOSKAR BROTHERS LIMITED</b>	NO. HA13729KB0-0	
<b>PERFORMANCE CURVE OF PUMP KPD125/28</b>	SUC. 150 mm DEL. 125 mm	
THIS CURVE RELATES TO LIQUID OF SP.GR. = 1.0	n = 2800 rpm	
	NOMINAL	

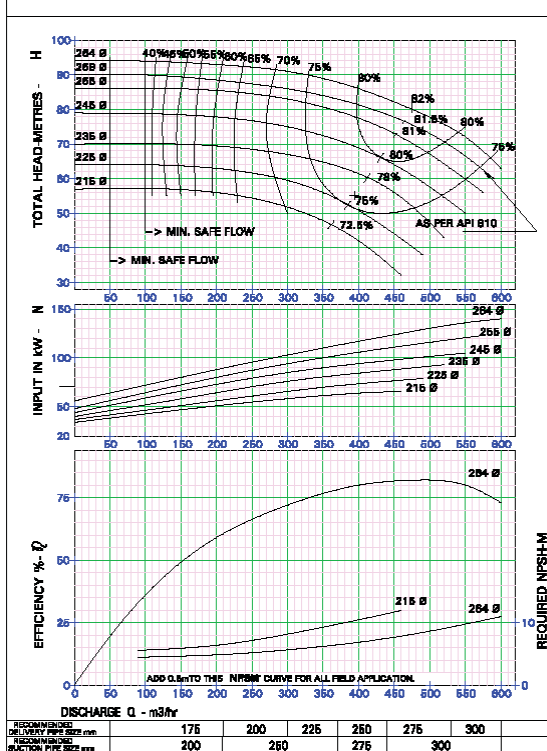

<b>KIRLOSKAR BROTHERS LIMITED</b>	NO. HA13729QB0-0	
<b>PERFORMANCE CURVE OF PUMP KPD 125/28 QF</b>	SUC. 150 mm DEL. 125 mm	
THIS CURVE RELATES TO LIQUID OF SP.GR. = 1.0	n = 1450 rpm	
	NOMINAL	

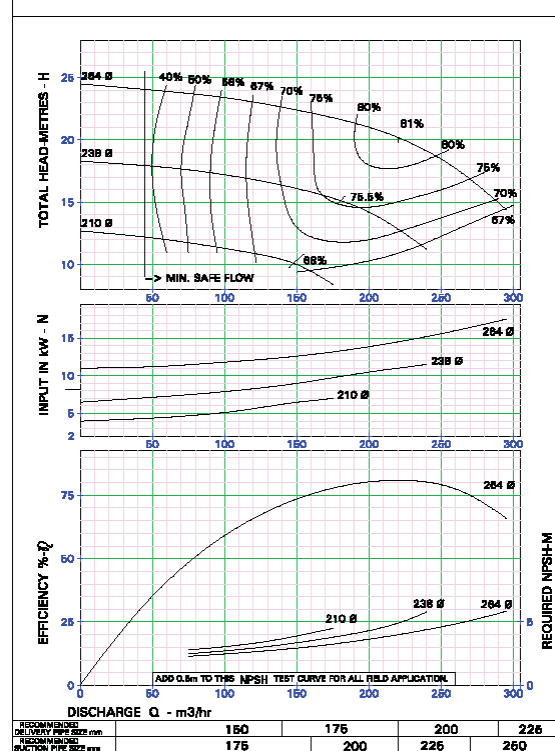

<b>KIRLOSKAR BROTHERS LIMITED</b>	NO. HD13730KB0-0	
<b>PERFORMANCE CURVE OF PUMP KPD 125/32</b>	SUC. 150 mm DEL. 125 mm	
THIS CURVE RELATES TO LIQUID OF SP.GR. = 1.0	n = 1450 rpm	
	NOMINAL	

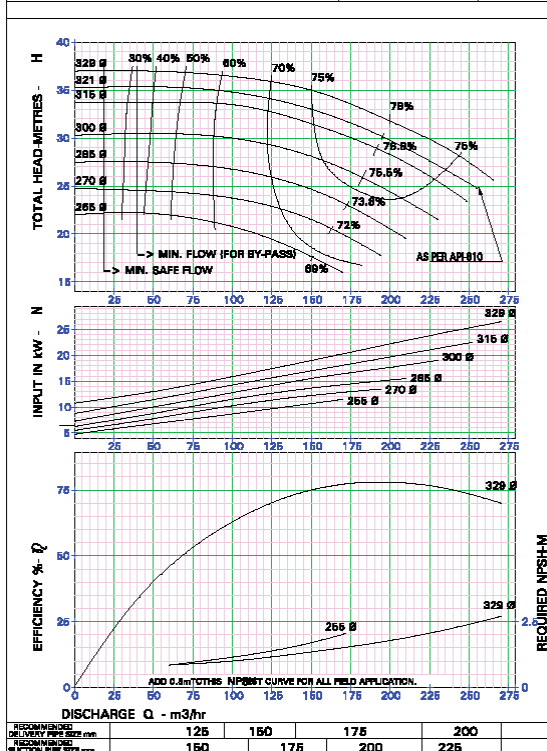

<b>KIRLOSKAR BROTHERS LIMITED</b>	NO. HA13730QB0-0	
<b>PERFORMANCE CURVE OF PUMP KPD125/32 QF</b>	SUC. 150 mm DEL. 125 mm	
THIS CURVE RELATES TO LIQUID OF SP.GR. = 1.0	n = 1450 rpm	
	NOMINAL	

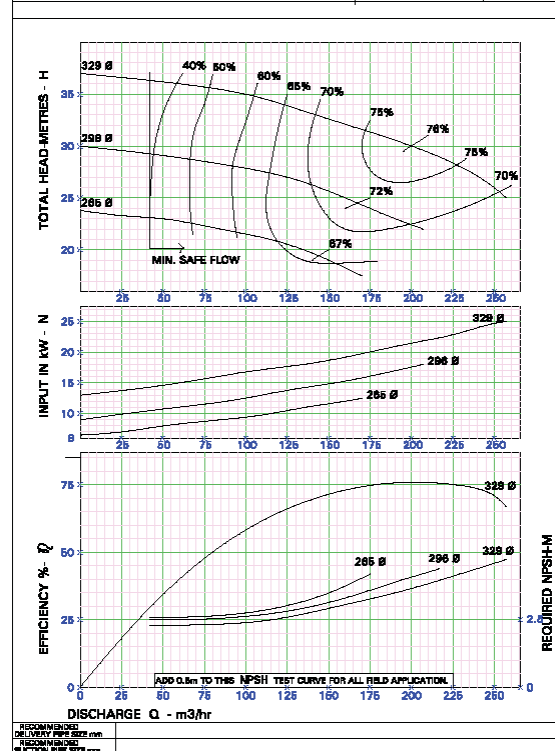

<b>KIRLOSKAR BROTHERS LIMITED</b>	NO. HD13731KBO 0	
PERFORMANCE CURVE OF PUMP KPD 125/40	SUC. 150mm DEL. 125mm n = 1450 rpm NOMINAL	
THIS CURVE RELATES TO LIQUID OF SP.GR. = 1.0		

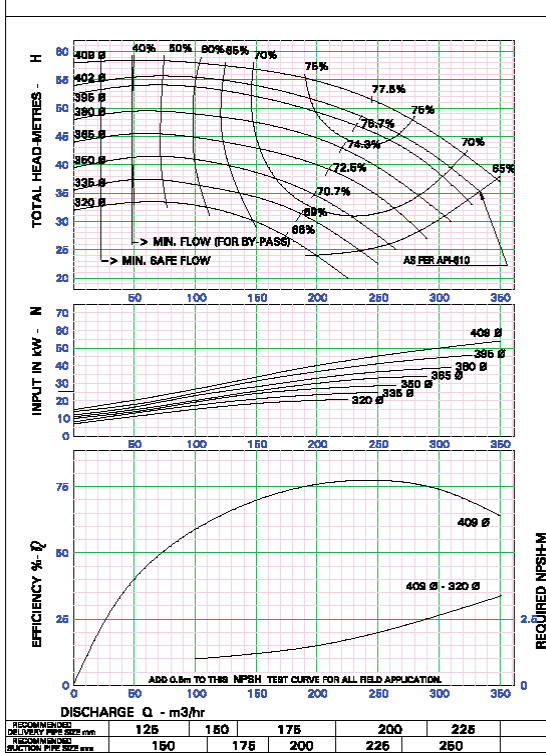

<b>KIRLOSKAR BROTHERS LIMITED</b>	NO. HD13769NBO 0	
PERFORMANCE CURVE OF PUMP KPD 125/40N	SUC. 160mm DEL. 125mm n = 1450 rpm NOMINAL	
THIS CURVE RELATES TO LIQUID OF SP.GR. = 1.0		

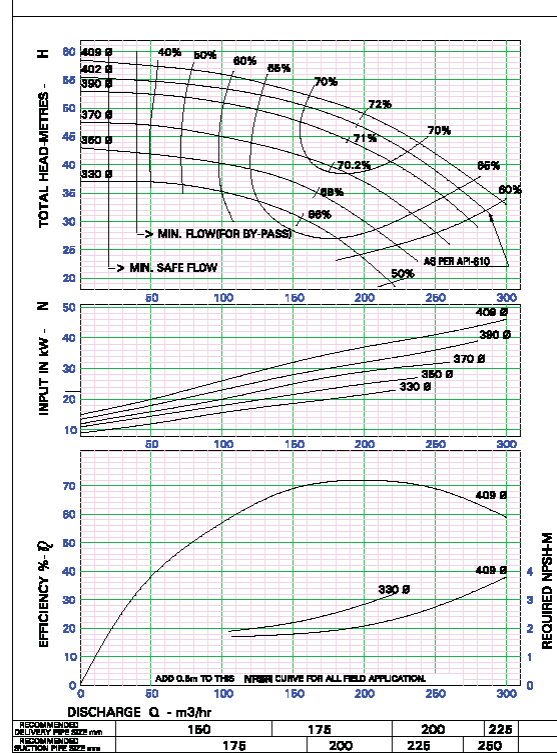

<b>KIRLOSKAR BROTHERS LIMITED</b>	NO. HA13731QBO 0	
PERFORMANCE CURVE OF PUMP KPD 125/40 QF	SUC. 150mm DEL. 125mm n = 1450 rpm NOMINAL	
THIS CURVE RELATES TO LIQUID OF SP.GR. = 1.0		

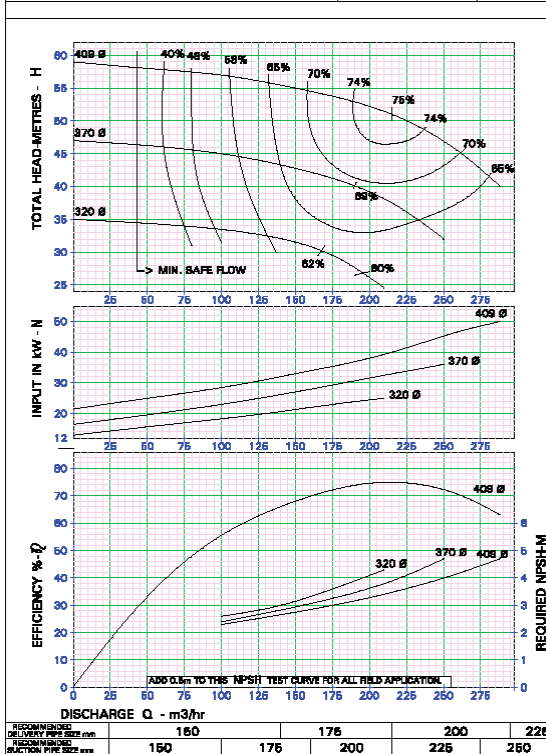

<b>KIRLOSKAR BROTHERS LIMITED</b>	NO. HD13761KBO 0	
PERFORMANCE CURVE OF PUMP KPD 125/46	SUC. 150mm DEL. 125mm n = 1450 rpm NOMINAL	
THIS CURVE RELATES TO LIQUID OF SP.GR. = 1.0		

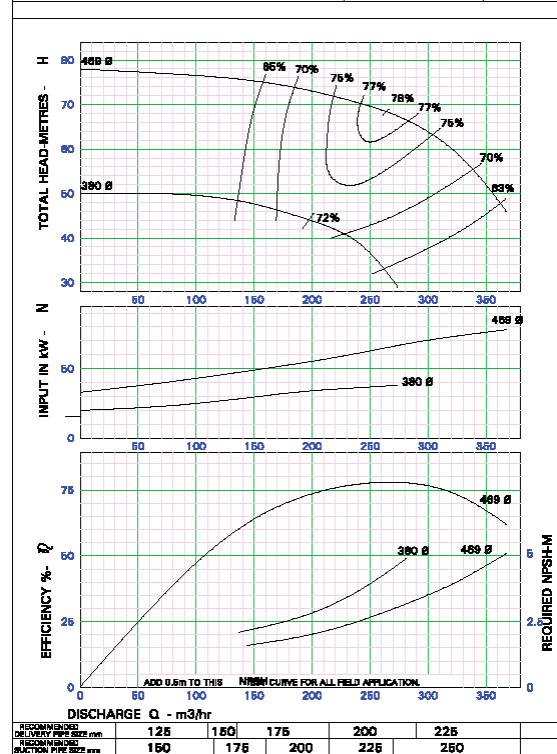

<b>KIRLOSKAR BROTHERS LIMITED</b>	NO. HD13732KBO 0	
PERFORMANCE CURVE OF PUMP KPD 160/32	SUC. 200mm DEL. 150mm	
THIS CURVE RELATED TO LIQUID OF SP.GR. = 1.0	n = 1460 rpm	NOMINAL

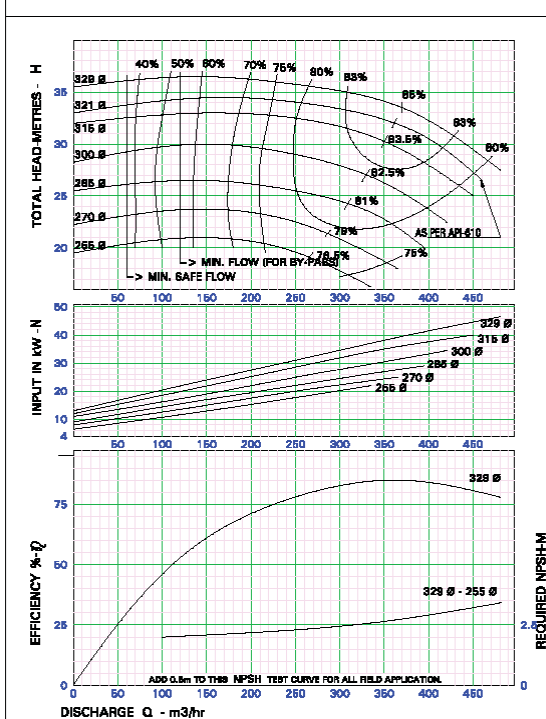

RECOMMENDED DELIVERY PIPE SIZE mm	175	200	225	250	275
RECOMMENDED SUCTION PIPE SIZE mm	200	250	275	300	300

<b>KIRLOSKAR BROTHERS LIMITED</b>	NO. HD13744NBO 0	
PERFORMANCE CURVE OF PUMP KPD 160/32N	SUC. 200mm DEL. 150mm	
THIS CURVE RELATED TO LIQUID OF SP.GR. = 1.0	n = 1450 rpm	NOMINAL

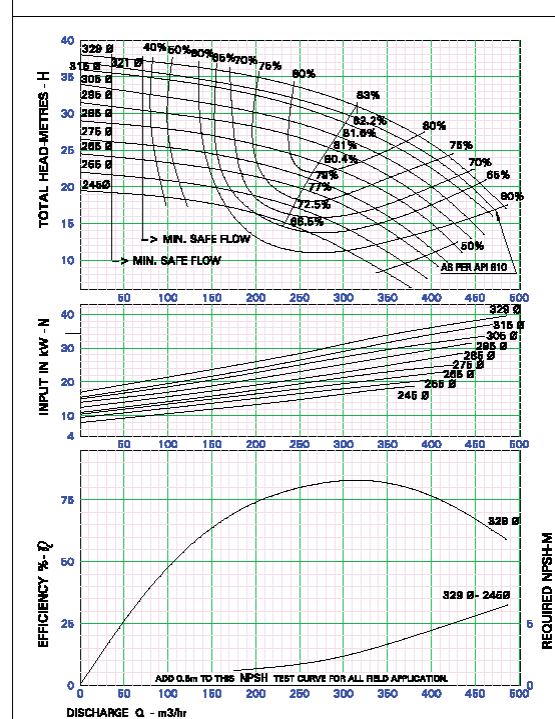

RECOMMENDED DELIVERY PIPE SIZE mm	175	200	225	250	275
RECOMMENDED SUCTION PIPE SIZE mm	200	250	275	300	300

<b>KIRLOSKAR BROTHERS LIMITED</b>	NO. HA13732QBO 0	
PERFORMANCE CURVE OF PUMP KPD 160/32 QF	SUC. 200mm DEL. 150mm	
THIS CURVE RELATED TO LIQUID OF SP.GR. = 1.0	n = 1450 rpm	NOMINAL

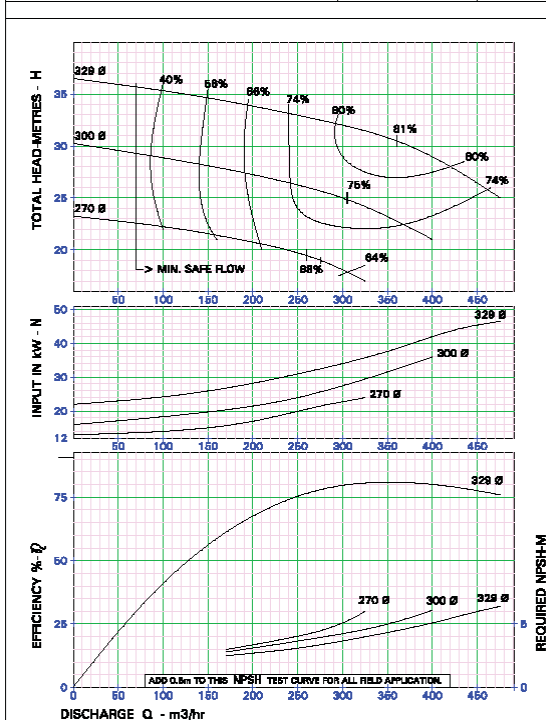

RECOMMENDED DELIVERY PIPE SIZE mm	175	200	225	250	275
RECOMMENDED SUCTION PIPE SIZE mm	200	250	275	300	300

<b>KIRLOSKAR BROTHERS LIMITED</b>	NO. HD13733KBO 0	
PERFORMANCE CURVE OF PUMP KPD 160/40	SUC. 200mm DEL. 150mm	
THIS CURVE RELATED TO LIQUID OF SP.GR. = 1.0	n = 1470 rpm	NOMINAL

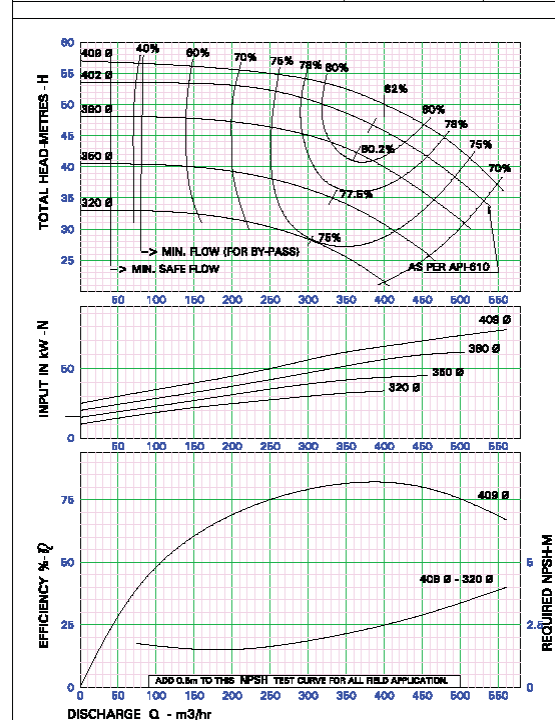

RECOMMENDED DELIVERY PIPE SIZE mm	160	175	200	225	250	275
RECOMMENDED SUCTION PIPE SIZE mm	175	200	225	250	275	300

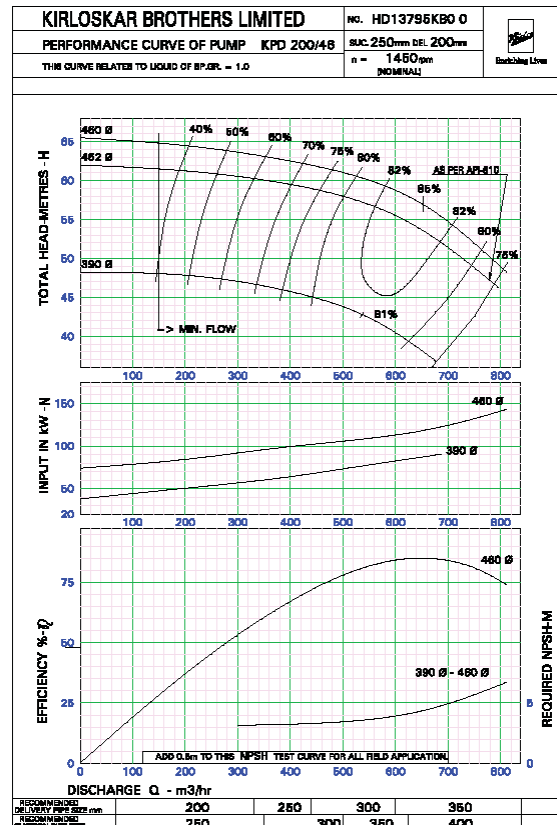
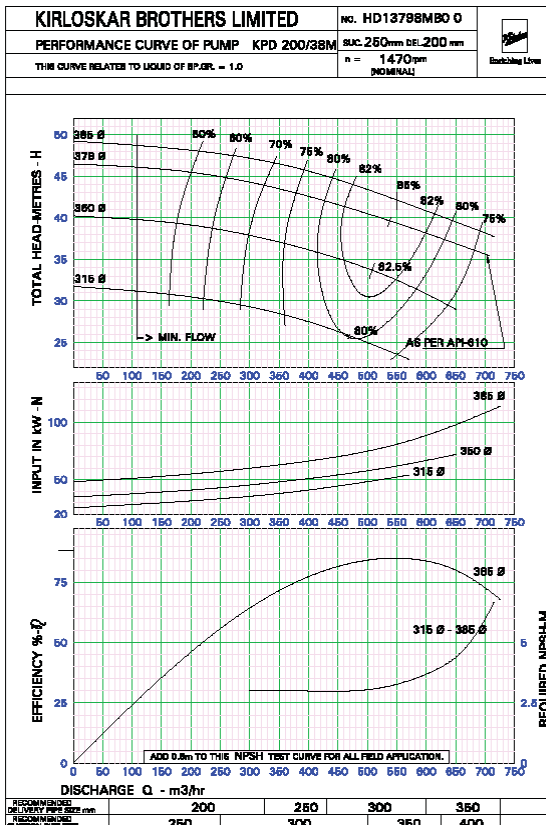
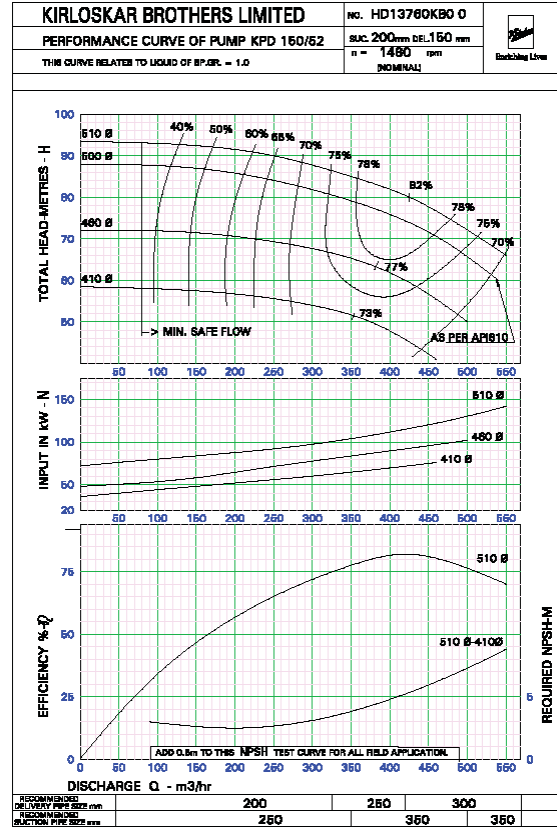
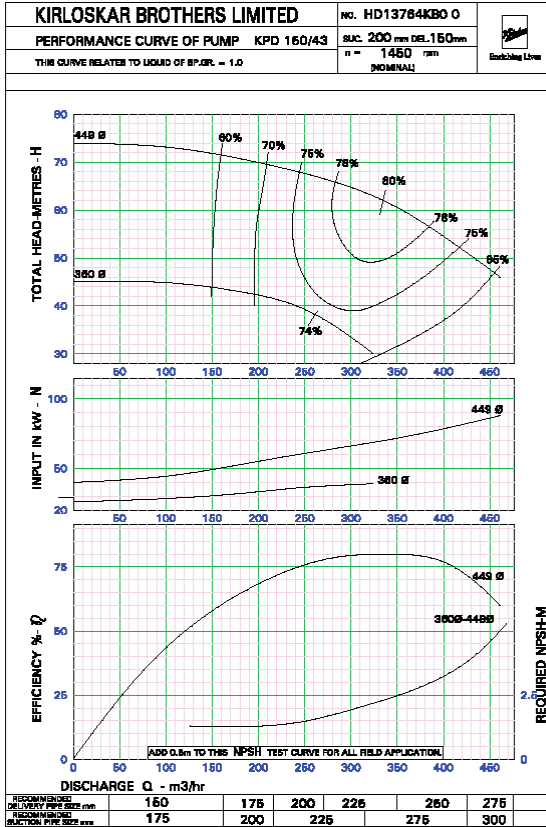

## Torque speed curve

GT006 0

### STARTING TORQUE SPEED CURVE

CASE I Starting up with open isolating or regulating valve on delivery side

CASE II Starting up with a closed isolating or regulating valve with opening the valves when nominal speed is attained.

CASE III Starting up with an open isolating or regulating valve but against a static delivery head static on a non return valve.

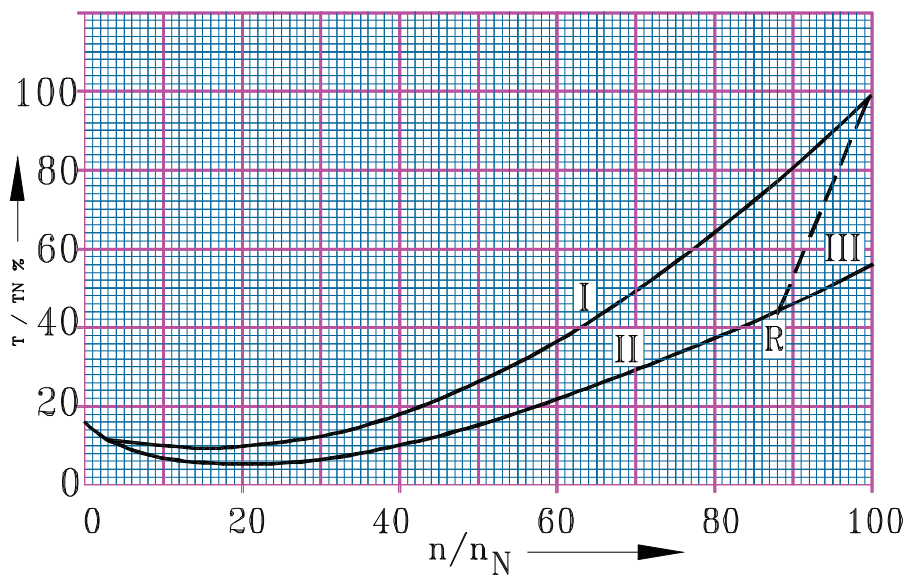

n - Speed

T - Torque at speed n

TN- Nominal torque

nN- Nominal speed

Note :- Case II is applicable to KPD pumps however motor should be designed & suitable for all the 3 cases.

## **G- Constructional features:**

KPD pump is a horizontal, single stage centrifugal end suction volute pump with top centre line delivery branch. The pump feet are integrally cast with the delivery casing. The bearing housing is fitted with a support foot. The pump shaft is carried in oil lubricated antifriction bearings. The impeller is of an enclosed or semi-open type as specified in models.

### **a. Special features:**

In this pump the complete driving unit can be withdrawn from the driving end without disturbing suction or delivery pipelines. Owing to its back pull out design, the motor too remains in position if spacer type coupling is used.

KPD pumps are as per ISO:2858 and DIN:24256 and generally conforms to API:610,7th edition with some deviations.

A - A large degree of standardized components.

B - Smaller inventory of spare parts due to modular design.

C - Ease of maintenance.

D - Very high service reliability

### **b. Performance Range**

(A) At 1450 rpm

Rate of flow up to 900 m<sup>3</sup>/hr.

Head up to 95 met.

(B) At 2900 rpm

Rate of flow up to 550 m<sup>3</sup>/hr.

Head up to 230 met.

### **c. Net Positive Suction Head**

The values obtained on test bed are plotted on performance curves. A safety margin of 0.5 meters minimum must be added for applying the same for site conditions.

### **d. Minimum Safe Flow Rate**

Minimum safe flow for KPD pumps is 10% of best efficiency point capacity  
Provided –

i. Temperature of liquid being pumped is less than 90°C.

ii. Available NPSH is greater than NPSHR value by 0.5 meters at minimum safe flow discharge.

iii. Vapour pressure of liquid is less than vapour pressure of water at all temperatures.

iv. Thermal capacity of liquid greater than thermal capacity of water.

### **e. Constructional features:**

#### **1. Casing details:**

It has axial suction and top centerline delivery. It is designed for back pullout arrangement. Casing walls are of ample cross section to resist pipe strain at suction and discharge without distortion. 3 mm extra corrosion allowance on casing wall thickness is provided. Suction nozzle is large enough to ensure favourable flow conditions to the impeller eye and low NPSH requirement.

#### **2. Flanges:**

Flanges for KPD pumps are drilled as per following standards:

1. ANSI B 16.1, CL-125, FF – for Cast Iron
2. ANSI B 16.5, CL-150, RF - for Cast Steel and Stainless steel

**Flange nozzle sizes:**

Pump Model	SUCTION (MM)	DELIVERY (MM)
20/13, 20/16, 20/20.	25	20
25/16, 25/20	40	25
32/13, 32/16, 32/20, 32/26.	50	32
40/13, 40/16, 40/20, 40/26, 40/32.	65	40
50/13, 50/16, 50/20, 50/26, 50/32.	80	50
65/13, 65/16, 65/29, 65/26, 65/32, 65/43	100	65
80/16, 80/26, 80/32, 80/40.	125	80
100/20, 100/26, 100/32, 100/40.	125	100
125/26, 125/32, 125/40, 125/45	150	125
150/32, 150/40, 150/43, 150/52	200	150
200/38M, 200/46.	250	200
25/26A	50	25

**3. Tapping details :**

Pumps are supplied with NPT tapping as a standard

**4. Impeller**

Impellers of KPD pumps are enclosed type or semi-open type. The hydraulic axial thrust in enclosed impellers is balanced either by providing back vanes or by drilling balancing holes depending upon magnitude of axial thrust.

**5. SHAFT**

It is designed for the toughest service. The critical speed of the shaft is well above the operating speed. Shaft is supported in antifriction bearings and is fully protected from the liquid handled by the pump by means of fully confined gasket between the impeller nut - impeller hub and shaft sleeve - impeller hub.

**SHAFT DIMENSIONS**

Driving Unit No.	Diameter under Coupling (MM)	Diameter Shaft Sleeve (MM)	Diameter under Impeller (MM)
KPD-4	18	19	16
KPD-5	24	24	20
KPD-7	32	34	28
KPD-9	42	44	38
KPD-11	48	44	38
KPD11A, 11B	48	44	38
KPD-13	60	60	55

## 6. Bearing & lubrication

### (A) Bearing details:

Bearing Size	Driving End.	Non-Driving End.
Unit No.		
5	SKF-7206 BECB (2 Nos./1 pair)	SKF-NU305 (1 No.)
7	SKF-7307 BECB (2 Nos./1 pair)	SKF-NU307 (1 No.)
9	SKF-7309 BECB (2 Nos./1 pair)	SKF-NU309 (1 No.)
11 KPD125/26 at 2900 RPM 11 A ,11B (KPD 125/45 & KPD 150/43)	SKF-3311  SKF 7311 (2 Nos./1 Pair)	SKF-NU311 (1NO.)  SKF NU311
13	SKF-7313 BECB (2 Nos./1 pair)	SKF-NU313 (1 No.)

### (B) Bearing details for KPD pumps with semi-open impeller i.e. KPDQF.

Bearing Size	Driving End.	Non-Driving End.
Unit No.		
4	SKF-6304 (1 No.) & SKF-7304 (1 No.)	SKF-6304 (1 No.)
5	SKF-7206 BECB (2 Nos./ 1 pair)	SKF-NU305 (1 No.)
7	SKF-7307 BECB (2 Nos./ 1 pair)	SKF-NU307 (1 No.)
9	SKF-7309 BECB (2 Nos./ 1 pair)	SKF-NU309 (1 No.)

**NOTES:**

1. Bearings of SKF make are used.
2. The bearing arrangement mentioned above are suitable for suction pressure less than 5 kg/cm<sup>2</sup>. For applications involving suction pressure above 5 kg/cm<sup>2</sup>, please refer to Marketing Division, HO Pune.
3. C3 clearance bearings are used.
4. Axial running clearance shall be less than 0.45 mm for all above bearing arrangements.
5. Maximum allowable temperature of bearing shall be 80°C.
6. Bearings are oil lubricated. Oil level in the bearing housing is maintained up to the desired level with the help of constant level oiler. Constant level oiler is our standard scope of supply.
7. In case of pumping liquids above 180°C, cooling of lubricating oil shall be necessary. However bearing housing cooling arrangement shall be provided at an extra cost and against specific request only.

**7. Stuffing box:**

Efficient cooling of the packing/mechanical seal is achieved by formation of a cooling chamber in the stuffing box portion ensuring thereby long life of packing/ mechanical seal. No requirement of separate cooling jacket as cooling chamber is formed by virtue of arrangement of lantern bracket and casing cover. If stuffing box cooling is required, please specify HOT MODELS for example KPD 50/20H. Change over from a mechanical seal arrangement to soft packing arrangement and vice versa is made very simple with the help of few standardised conversion parts. Re machining of the stuffing box is not necessary in most of the mechanical seals. Mechanical seal is supplied in "cartridge" construction exclusively and is to be fitted from impeller end. The pump can be fitted with a drip pan for stuffing box leakage (against order only).

**7.1 General Selection of Gland Packing and Gasket Material**

Pumps are supplied with gasket and gland packing in non asbestos MOC. For gasket Ferrolite NAM 37 or EQ and for gland packing Champion 3116 or EQ is standard scope of supply.

**NOTE:** Against requirement, special gland packing and gasket material can be supplied at extra cost.

**7.2 Mechanical seals:**

Whenever mechanical seal is required, anyone of the following cartridge type seal shall be used unless specified. The seal selected and face combination of the seal shall be compatible to the service and application of the pump.

	<b>EPIL</b>	<b>LEAK PROOF</b>	<b>FLOWSERVE</b>	<b>AES</b>
<b>SEAL</b>	E11	70U/C	R0	M04
<b>TYPE</b>	E12	75U/C	R0TT	M04S
	P13	80U/C	P50	
	L9AW	85U/C		

	LEAK-PROOF	EPIL		
DRIVING UNIT	70U/75U/C UNBALANCED SINGLE SPRING	80U,85U/C UNBALANCED MULTI SPRING	E11,E12SINGLE COIL SPRING UNBALANCED	P13 ROTATING MULTI SPRING BALANCED
4	1"	1"	E11D16,E12D16	P13D16
5	1.25"	1.25"	E11D20,E12D20	P13D20
7	1.625"	1.625"	E11D28,E12D28	P13D28
9	2"	2"	E11D34,E12D34	P13D34
11	2"	2"		
13	2.625"	2.65"		

**Note:**

Seal faces will be generally C vs Cer, C vs Tc or C vs. SiC and will vary depending upon application.

Seals will be in SS316 material with Viton elastomers.

Seals are suitable for temperature up to 90°C.

**Stuffing box cooling:**

If the operating temperature of pump exceeds the limit T; given in the chart, it becomes necessary to cool the stuffing box.

Construction	Temp. T"	Remarks
Packed glands	105°C	Limit is subject to change as per clients requirement.
Mechanical	* 140°C	Limit is subject to change as per seal manufacturer's recommendations.

\* For more volatile liquids, this limit may come to a lower value.

**8. Shaft sleeves :**

It is a hook type shaft sleeve with one end free to expand with temperature variations. Labyrinth type deflector is mounted on the shaft sleeve in case of gland packed pumps.

**9. DRIVE**

**1.8.1 Direct drive:**

The pump can be driven by electric motor or engine.

**1.8.2 Indirect drive:**

Pump can be driven by gear or belt drive.

**1.8.3 Direction of rotation:**

The direction of rotation is clockwise when viewed from coupling end.

**H- CROSS SECTIONAL DRAWINGS WITH MOC OPTION:**

**MATERIAL OF CONSTRUCTION:**

The list of contains only materials of construction of the main parts. The material for all other parts (e.g. bolts and gaskets) is selected according to the material of construction of main parts and the applications.

**MATERIAL OF CONSTRUCTION CHART**

MOC CODE	PART DESCRIPTION														
	PUMP CASING	IMPELLER	PUMP SHAFT	CASING RING	IMPELLER RING	LANTERN RING	SPLIT GLAND	MECH.SEAL COVER	LIQUID DEFLECTOR	BRG.HOUSING	LANTERN BRACKET	SHAFT SLEEVE(GLAND PACKED)	SHAFT SLEEVE (MECH.SEAL)	IMPELLER NUT	STUFFING BOX BUSH
01	012	012	684	012	110	012	012	253	012	012	012	556	253	012	012
02	012	110	684	012	110	012	012	253	110	012	012	556	253	253	012
03	012	112	684	012	112	012	012	253	112	012	012	556	251	251	012
04	110	110	684	110	110	251	232	253	110	012	012	556	253	253	251
05	112	112	684	112	112	251	232	253	112	012	012	251	251	251	251
07	012	034	684	034	034	012	012	253	034	012	012	556	253	034	034
08	035	035	684	035	035	012	012	253	035	012	012	556	253	253	012
09	012	202	684	012	202	012	012	253	012	012	012	556	253	253	012
10	202	202	684	554	559	253	202	253	253	012	012	556	253	253	253
11	012	232	684	012	232	012	012	251	251	012	012	251	251	251	012
12	202	110	684	110	110	253	202	253	253	012	012	251	251	253	253
18	202	012	684	012	110	012	012	253	012	012	012	556	253	012	012
19	215	012	684	012	110	012	012	253	012	012	012	556	253	012	012
21	012	035	684	012	035	012	012	253	035	012	012	556	253	012	012
23	012	231	684	012	559	012	012	253	253	012	012	556	253	253	012
24	231	231	253	554	559	253	231	253	253	012	012	556	253	253	253
25	012	113	684	012	113	012	012	253	113	012	012	251	251	251	012
26	113	113	253	113	113	251	232	113	113	012	012	251	251	251	251
27	012	211	684	012	211	012	012	251	251	012	012	251	251	251	251
28	211	211	253	211	211	251	232	211	251	012	012	251	251	251	251
29	235	235	253	235	235	235	235	235	235	012	012	235	235	235	235
30	237	237	253	237	237	685	237	237	237	012	012	685	685	237	237

36	220	220	253	220	220	207	220	220	220	012	012	207	207	220	220
37	221	221	253	221	221	221	221	221	221	012	012	221	221	221	221
38	223	223	253	223	223	223	223	223	223	012	012	223	223	223	223
39	224	224	253	224	224	224	224	224	224	012	012	224	224	224	224
41	012	012	253	012	110	012	012	253	012	012	012	556	253	012	012
42	012	012	251	012	110	012	012	253	012	012	012	556	253	012	012
43	012	110	253	012	110	012	012	253	110	012	012	556	253	253	012
44	012	110	251	012	110	012	012	253	110	012	012	556	253	253	012
45	012	110	684	110	110	012	012	253	110	012	012	556	253	253	012
46	012	110	253	110	110	012	012	253	110	012	012	556	253	253	012
47	110	110	253	110	110	251	232	253	110	012	012	556	253	253	251
48	110	110	251	110	110	251	232	253	110	012	012	556	253	253	251
49	112	112	253	112	112	251	232	253	112	012	012	251	251	251	251
50	112	112	251	112	112	251	232	253	112	012	012	251	251	251	251
51	035	035	253	035	035	012	012	253	035	012	012	556	253	253	012
52	035	035	251	035	035	012	012	253	035	012	012	556	253	253	012
53	202	202	253	554	559	253	202	253	253	012	012	556	253	253	253
54	202	202	251	554	559	253	202	253	253	012	012	556	253	253	253
55	012	233	684	233	233	233	012	253	233	012	012	233	233	233	012
56	202	232	253	554	232	253	202	253	253	012	012	556	253	253	253
57	202	232	251	554	232	253	202	253	253	012	012	556	253	253	253
58	202	035	253	554	035	253	202	253	253	012	012	556	253	253	253
59	012	232	253	012	232	012	012	253	251	012	012	251	251	251	012
60	012	232	251	012	232	012	012	253	251	012	012	251	251	251	012
61	012	012	684	012	110	012	202	253	012	012	012	556	253	012	012
62	012	110	684	012	110	012	202	253	110	012	012	556	253	253	110
63	202	012	684	012	110	012	202	253	012	012	012	556	253	012	012
78	240	240	250	240	240	250	240	250	250	012	012	250	250	250	250
79	233	233	253	233	233	251	232	233	233	012	012	233	233	233	251
80	240	240	251	240	240	250	240	250	250	012	012	250	250	250	250
85	012	012	684	012	110	012	012	253	012	012	012	251	251	012	012
88	012	237	684	237	237	085	012	253	237	012	012	685	685	237	237
89	012	223	684	223	223	223	012	253	223	012	012	223	223	223	223
90	012	224	684	224	224	224	012	253	224	012	012	224	224	224	224
91	012	221	684	221	221	221	012	253	221	012	012	221	221	221	221
92	012	220	684	220	220	207	012	253	220	012	012	220	207	220	220
93	243	243	222	243	243	243	243	685	243	012	012	243	685	243	243
94	012	240	684	240	240	250	012	253	250	012	012	250	250	250	250
95	240	240	253	240	240	250	240	250	250	012	012	250	250	250	250

## LIST OF MATERIAL FOR KPD PUMPS

MAT. CODE	MATERIAL DESCRIPTION
000	STEEL
011	CI IS 210-FG 200
012	CI IS 210-FG 260
034	CI IS 210 FG 260 NI 1.5 (MIN)
035	CI IS 210 FG 260 NI 2 (MIN)
053	CS IS 1570 PART II - 40 C8 HOT ROLLED
110	BRONZE IS 318 GR LTB2
112	PHOSPHER BRONZE IS 28 - 1
113	SILICON BRONZE IS 1028
202	CAST STEEL ASTMA 216/216 M WCB
211	AUST. IRON IS 2749 GR AFG NI 20 Cr3
215	SG IRON IS 1865 - SG 500/7
220	MONEL ASTMA 494 G M 35-1
221	K 5 ALLOY
222	K-MONEL (RODS&BARS) ASTMB 164 U N S NO. 4400 (COLD WORKED STRESSRELVD)
223	HASTELLOY-B
224	HASTELLOY-C
231	ST ST ASTMA 217/217 M - CA15
232	ST ST ASTMA 351/351 M - CF8M
233	ST ST ASTMA 351/351 M - CF8C
235	ST ST GR CF6M
237	ST ST ASTMA 743/743 M - CN7M
240	ST ST ASTMA 743/743 M - CF8
243	ST ST ASTMA 743/743 M CN7MS
246	ST ST ASTMA 351/351 M CF3
247	ST ST ASTMA 351/351 M GR CF3 M
250	ST ST ASTMA-276 TYPE 304 ANNEALED
251	ST ST ASTMA-276 TYPE 316
253	ST ST ASTMA-276 TYPE 410 ANNEALED
289	ST ST ASTMA-276 TYPE 304 L ANNEALED
554	ST ST ASTMA 217/217 M-CA15 340 BHN (MIN)
556	ST ST ASTMA 276-410 300 BHN (MIN)
559	ST ST ASTMA-276 TYPE-410 (250-280 BHN)
584	ALLOY STEEL ASTMA 322 - 4140 ANNEALED
999	UN-USUAL MATERIAL
684	ASTMA 322-4140 (ANLD) EN19
685	ASTMB 473 UNS 8020 (ALLOY 20BAR)

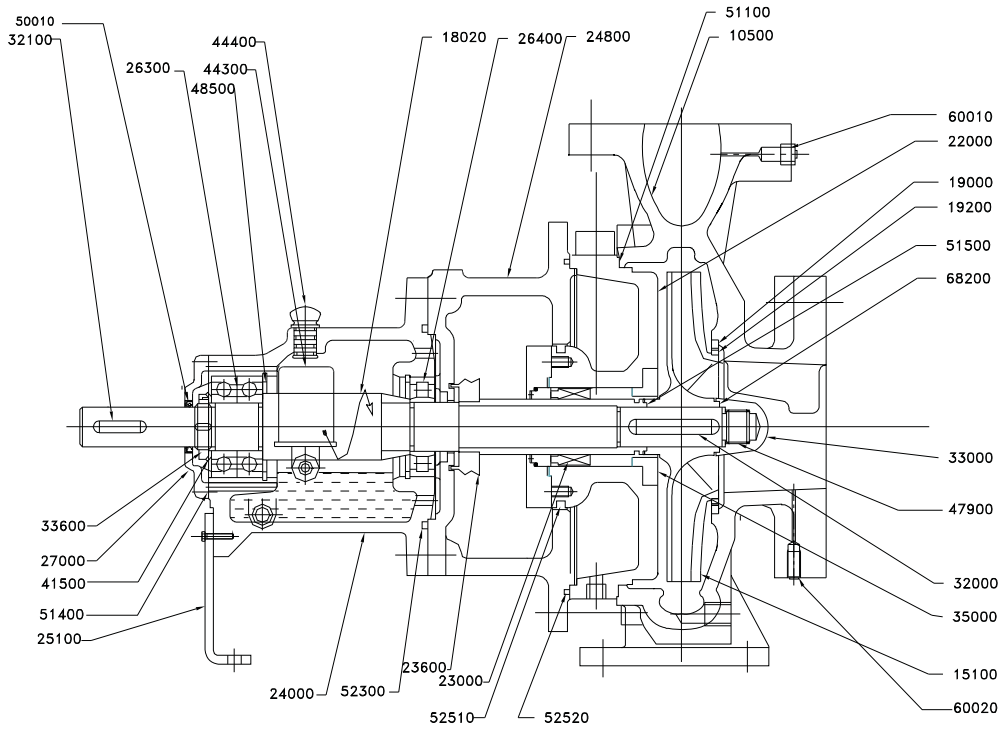

**Cross sectional assembly of KPD pump (KPD 32,40,50&65/13)  
Enclosed impeller with deep groove ball bearing arrangement**

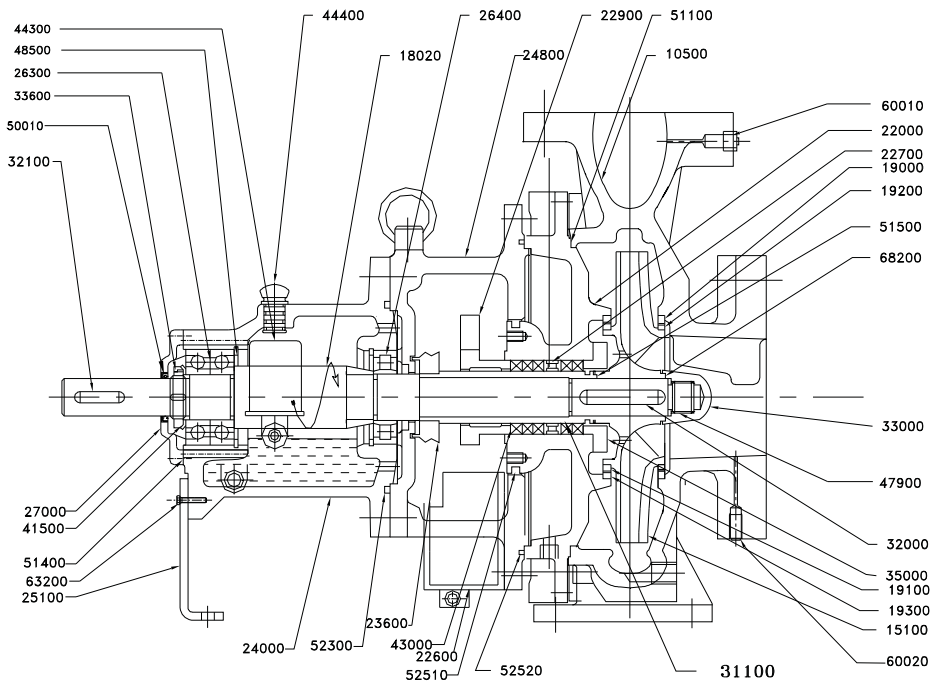

**Cross sectional assembly of KPD pump(KPD 32 to 80/16 ,32 to 100/20,  
32 to 125/26)  
Enclosed impeller with reinforced bearing arrangement**

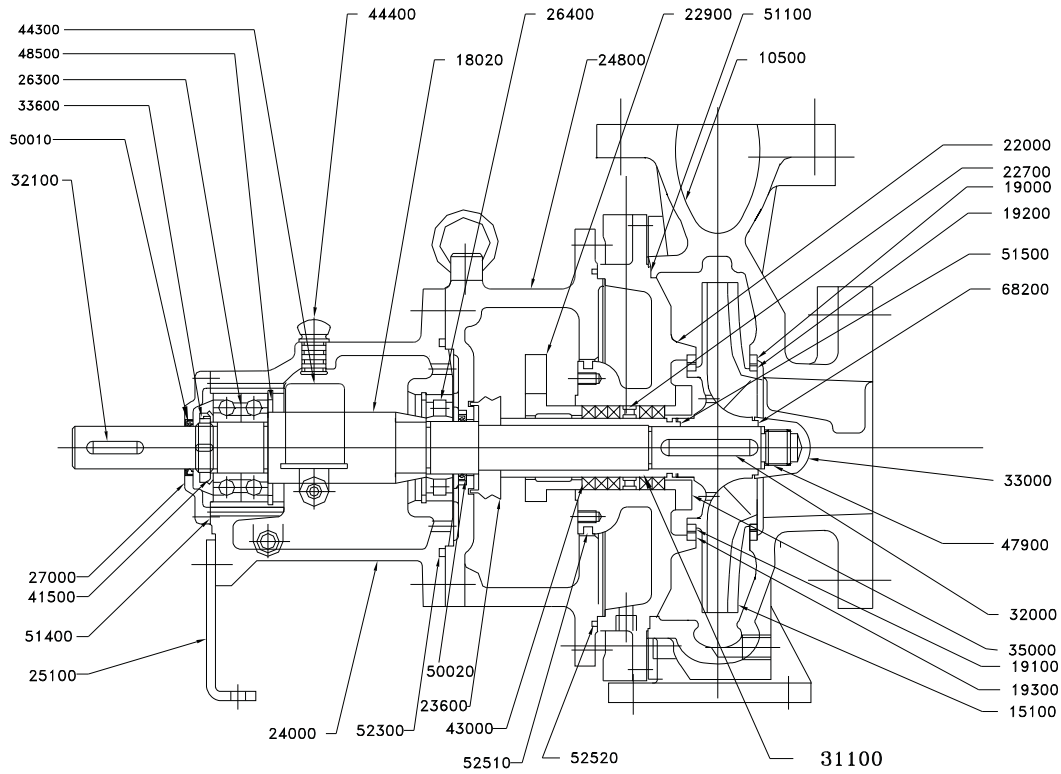

**Cross section assembly of KPD 65/43, KPD 125/45, KPD 150/43, KPD 150/52 pump.**

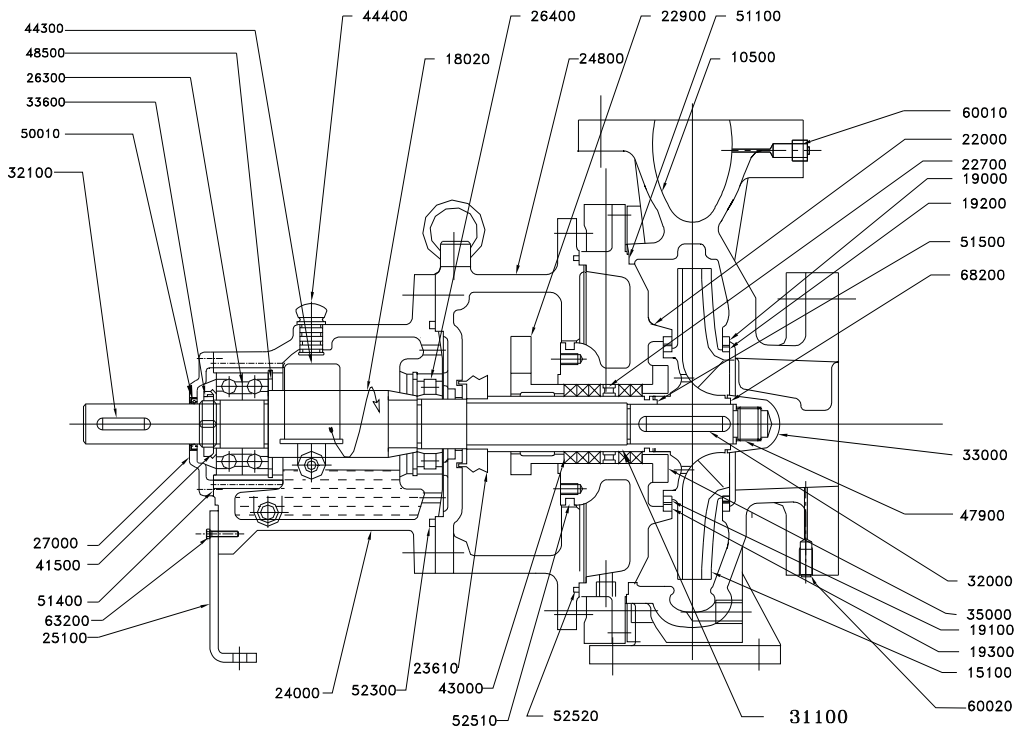

**Cross sectional assembly of KPD pump(KPD 11 unit)  
Enclosed impeller KPD 150/32**

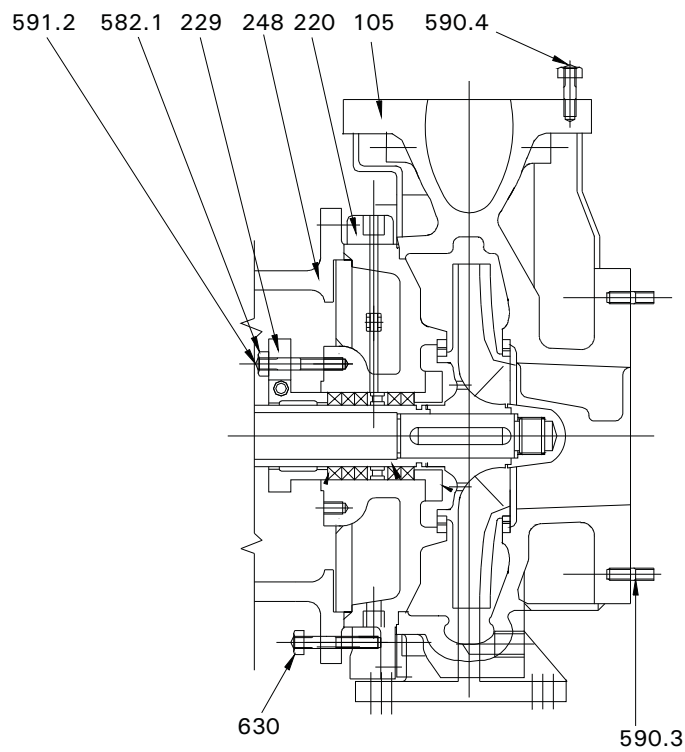

GENERAL CROSS-SECTIONAL DRAWING OF KPD STEAM JACKETED PUMP

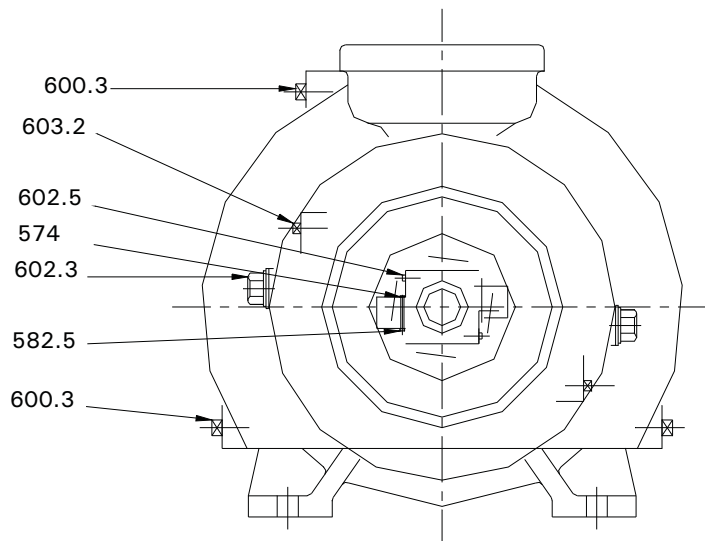

STEAM OR HOT WATER  
INLET CONNECTION SIDE

STEAM OR HOT WATER  
OUTLET CONNECTION SIDE

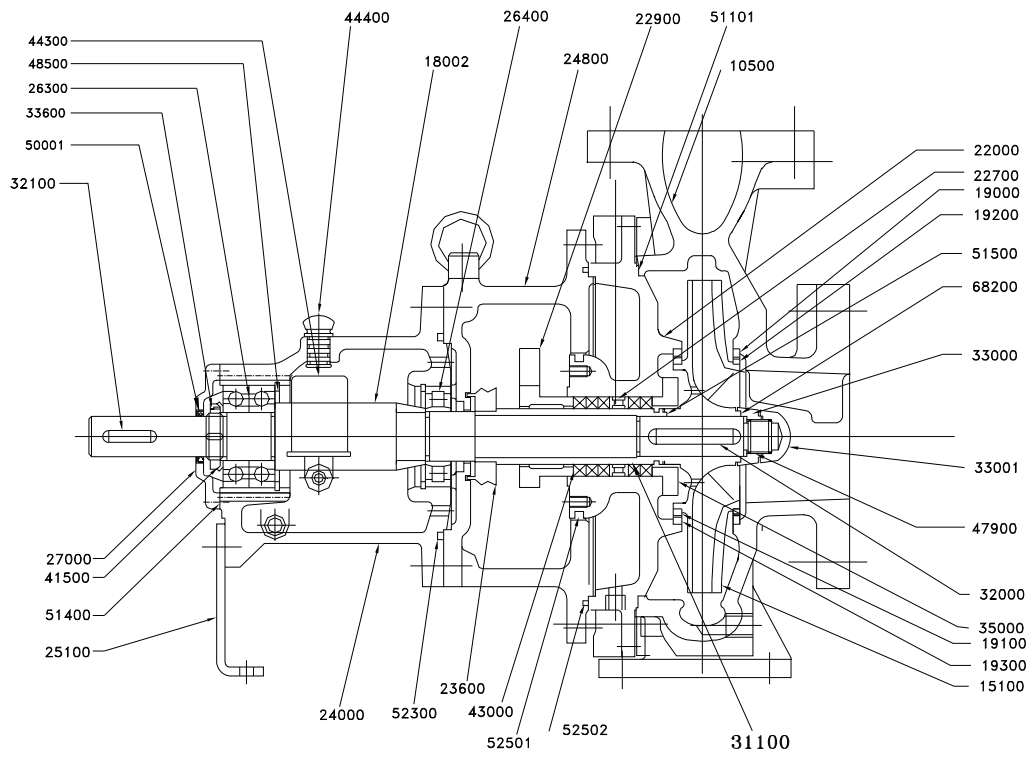

Cross sectional assembly drawing of KPD 200/38M & KPD 200/46 pumps

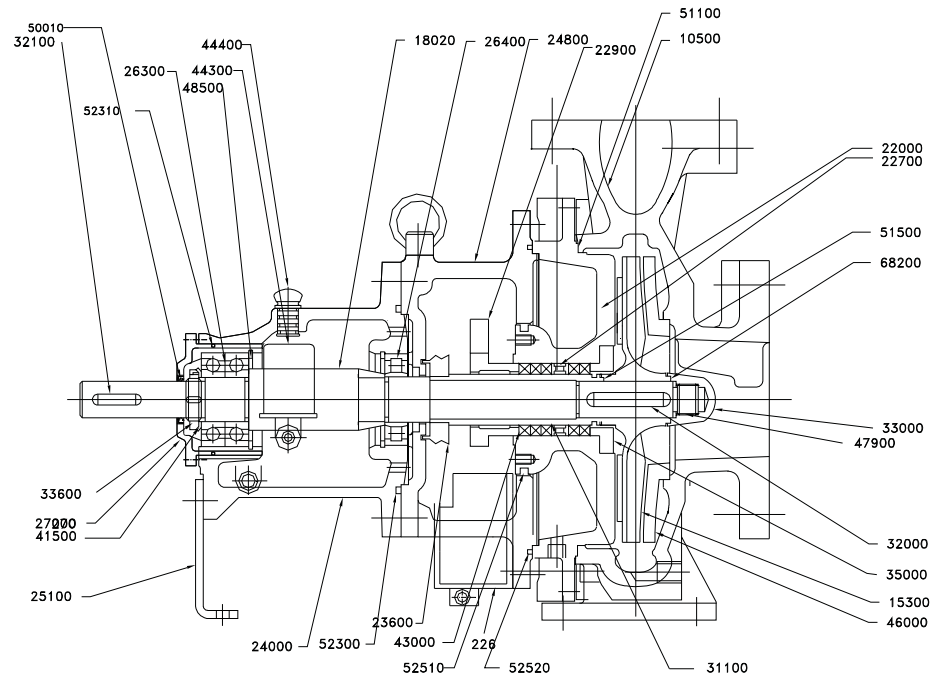

Cross-sectional assembly drawing of general KPD-QF pumps.

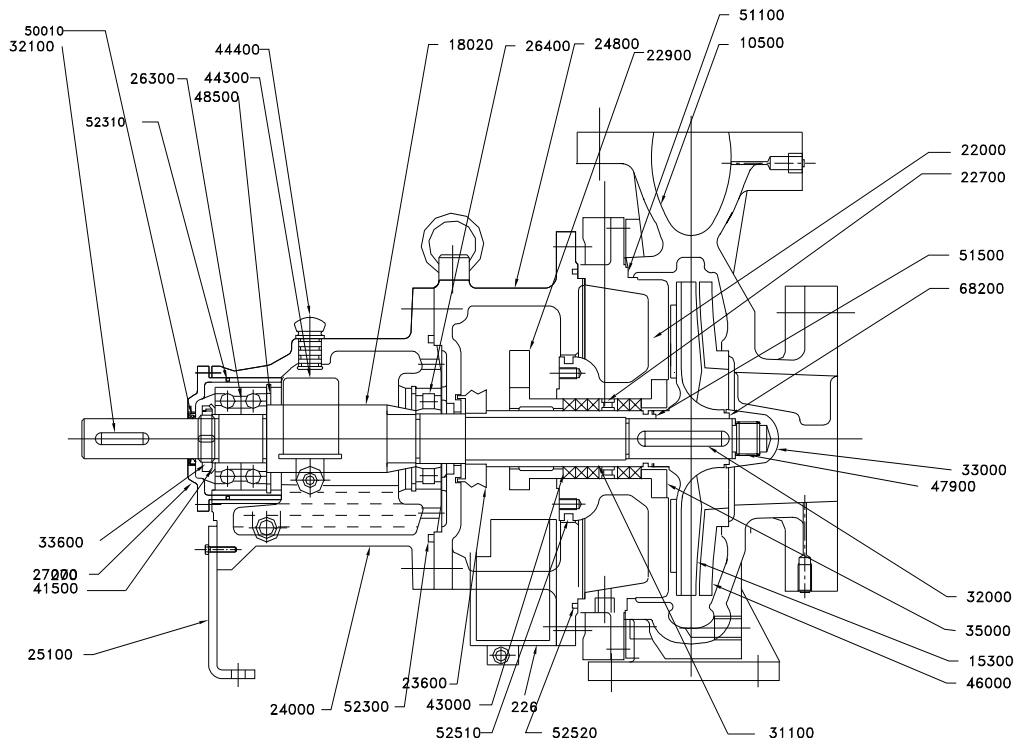

**Cross-sectional assembly drawing of KPD-QF 25/16 pump  
Semiopen impeller and fixed wear plate.**

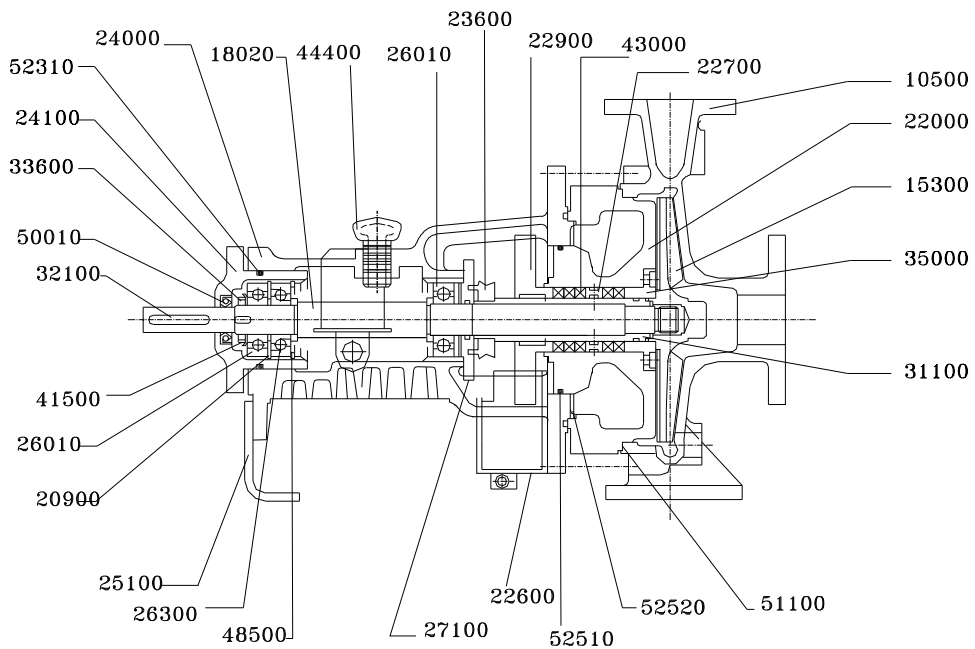

**Cross sectional assembly drawing of KPD 20/13QF pump.**

## PART NUMBER AND DESCRIPTION

<b>SR.NO</b>	<b>PART NO.</b>	<b>DESCRIPTION</b>
1	10500	Pump casing foot mounted.
2	10600	Pump casing centerline mounted.
3	15100*	Enclosed impeller.
4	15300*	Semi-open impeller.
5	18010*	Pump shaft (For deep groove ball bearing arrangement.)
6	18020*	Pump shaft (For reinforced bearing arrangement)
7	19000*	Casing wear ring (Suction side.)
8	19100*	Casing wear ring (Delivery side.)
9	19200*	Impeller ring (Suction side.)
10	19300*	Impeller ring (Delivery side.)
11	21900	Drip plate.
12	22000	Casing cover.
13	22600	Drip pan.
14	22700	Lantern ring.
15	22900	Split gland (1980).
16	23000*	Mechanical seal.
17	23100*	Mechanical seal cover.
18	23600	Liquid deflector for mechanical seal arrangement.
19	23610	Liquid deflector for gland packing arrangement.
20	24000	Bearing housing.
21	24800	Lantern bracket.
22	25100	Support foot.
23	25200	Bearing housing with cooling arrangement.
24	26010*	Ball bearing (DE).
25	26020*	Ball bearing (NDE).
26	26300*	Angular contact bearing (DE).
27	26400*	Cylindrical roller bearing (NDE).
28	27000	Bearing cover (DE).
29	31100*	Shaft sleeve (Pump side).
30	31500*	Shaft sleeve (Pump side).
31	32000	Key for impeller.
32	32100	Key for coupling.
33	33000*	Impeller nut.
34	33600*	Lock nut.
35	33800	Pipe nut.
36	35000*	Throat bush.
37	36010*	Throttling bush for quenching.
38	36020*	Throttling bush for double mechanical seal.
39	36700	Oil well cover.
40	37000	Cooling oil.
41	38400	Pump foot pad for centerline mounted pump casing.
42	39000	Flexible coupling – pump half.
43	39100	Flexible coupling – driver half.
44	39700	Spacer type coupling – Pump half.

<b>SR. NO</b>	<b>PART NO.</b>	<b>DESCRIPTION</b>
45	39800	Spacer type coupling – driver half.
46	39900	Spacer for spacer coupling.
47	40200	Coupling block.
48	40300*	Coupling star.
49	41500*	Lock washer for bearing nut.
50	43000*	Gland packing.
51	44300	Constant level oiler.
52	44400	Breather cap.
53	46000*	Wear plate.
54	46800	Orifice.
55	47900*	Helicoil screw lock insert.
56	48500*	Internal circlips.
57	49010*	Companion flange – suction side.
58	49020*	Companion flange – delivery side.
59	49030*	Slip on flange – suction side.
60	49040	Slip on flange – delivery side.
61	50010*	Oil seal – delivery side.
62	51100*	Gasket for casing cover.
63	51310*	Gasket for companion / slip-on flange – suction side.
64	51320*	Gasket for companion / slip-on flange – delivery side.
65	51400*	Gasket for bearing cover – delivery side.
66	51500*	Gasket for shaft sleeve and impeller.
67	51600*	Gasket for mechanical seal cover.
68	51750*	Gasket for pad cooling plug.
69	51770*	Gasket for constant level oiler.
70	51800*	Gasket for adaptor used in sealing connection.
71	59030	Stud for suction flange (steam jacket pump).
72	59040	Stud for delivery flange (steam jacket pump).
73	59110	Studs on casing cover to receive lantern bracket.
74	59120	Studs on casing cover to receive gland.
75	59130	Studs on casing cover to receive mech. seal cover.
76	59140	Studs on casing cover to receive mech. seal cover holding plate.
77	59150	Studs on mechanical seal cover to receive auxiliary gland.
78	59300	Studs on lantern bracket to receive bearing housing.
79	59400	Studs for wear plate.
80	60010	Plug for pressure gauge connection.
81	60020	Plug for suction gauge connection.
82	60030	Plug for steam jacket.
83	60100	Plug for pump casing drain.
84	60210	Plug for sealing connection on casing cover.
85	60220	Plug for sealing inlet connection on casing cover.
86	60230	Plug for sealing outlet connection on casing cover.
87	60250	Plug for jacketed gland.
88	60310	Plug for casing cover cooling inlet connection.

<b>SR NO.</b>	<b>PART NO.</b>	<b>DESCRIPTION</b>
89	60320	Plug for casing cover cooling outlet connection.
90	60330	Slotted collared plug.
91	60500	Plug for bearing housing drain.
92	60530	Plug for cooling inlet and outlet of bearing housing.
93	60910	Plug for flushing inlet on mechanical seal cover.
94	60920	Plug for quenching inlet and outlet.
95	61110	Pin for mechanical seal cover.
96	61120	Taper pin for pad.
97	62600	Washer for lock nut or wear plate.
98	63000	Hex. release screw for casing cover.
99	63110	Hex. screw for bearing cover – delivery side.
100	63120	Hex. screw for cover used in bearing housing cooling arrangement.
101	63200	Hex. screw for support feet.
102	64000	Rivets for name plates.
103	65010	Grub screw for casing wear ring – suction side.
104	65020	Grub screw for casing wear ring – delivery side.
105	65310	Hex. socketted grub screw for pump coupling.
106	65320	Hex. socketted grub screw for motor coupling.
107	65400	Grub screw for deflector.
108	52210*	'O'-ring for wear plate – suction side.
109	52220*	'O'-ring for wear plate – suction side.
110	52300*	'O'-ring for bearing housing and lantern bracket.
111	52510*	'O'-ring for casing cover and lantern bracket.
112	52520*	'O'-ring for lantern bracket and casing cover (only for hot models).
113	53110	Pipe nipple for pad cooling.
114	53120	Pipe nipple for pad cooling.
115	53220	Pipe nipple for quenching.
116	53310	Pipe nipple for casing drain.
117	53320	Pipe nipple for casing drain.
118	54000	(Pipe coupling) socket.
119	54210	Elbow for casing drain.
120	54500	Union joint.
121	55000	Wheel cock.
123	55810	Hex. nut for sealing pipe adapter.
124	55910	Adapter (male) on pump casing for sealing connection.
125	55920	Pipe adapter on casing cover for sealing connection.
126	55930	Adapter (male) for cooling piping.
127	55940	Adapter (male) for flushing piping (inbuilt office).
128	56010	Flushing inlet pipe.
129	56020	Flushing outlet pipe.
130	57010	Hex. bolts for companion / slip-on flanges – suction side.
131	57020	Hex. bolts for companion / slip-on flanges – delivery side.
132	57400	Hex. bolts for gland.
133	58010	Hex. nuts for companion / slip-on flanges – suction side.

<b>SR NO.</b>	<b>PART NO.</b>	<b>DESCRIPTION</b>
134	58020	Hex. nuts for companion / slip-on flanges – delivery side.
135	58100	Hex. nuts for casing studs.
136	58210	Hex. nuts for gland studs.
137	58220	Hex. nuts for mechanical seal cover / holding plate studs.
138	58230	Hex. nut for studs receiving lantern bracket and casing cover.
139	58240	Hex. nut for studs receiving casing cover.
140	58250	Hex. nuts for hex. bolts receiving gland.
141	58260	Hex. nuts for studs of auxiliary gland.
142	58600	Hex. nuts for studs receiving bearing housing and lantern bracket.
143	59020	Studs on pump casing to receive casing cover and lantern bracket.
144	66310	Grub screw for impeller ring – suction side.
145	66320	Grub screw for impeller ring – delivery side.
146	66610	Hex. socketted cap screw for stuffing box bush.
147	66620	Socketted grub screw for casing cover.
148	67000	Name plate for duties.
149	67110	Cooling water inlet name plate.
150	67120	Cooling water outlet name plate.
151	67200	Direction of rotation arrow name plate.
152	67300	Lubrication instruction name plate.
153	67610	Sealing water inlet name plate.
154	67620	Sealing water outlet name plate.
155	67910	Quenching inlet name plate.
156	67920	Quenching outlet name plate.
157	68200*	Gasket for impeller nut and impeller.
158	68400*	Gasket for lock nut.
159	68500*	Gasket for oil well cover.
160	69810*	Hex. nuts for wear plate studs.
161	69820*	Hex. lock nuts for wear plate bolts (BSP).
162	70100	Spring washer for bearing nut.
163	71300	Screw for drip plate.
164	71700	Hex. screw for centerline mounted pad.
165	78110	Flushing inlet name plate.
166	78120	Flushing outlet name plate.
167	78510	Steam inlet name plate.
168	78520	Steam outlet name plate.
169	80200*	Gasket for centerline mounted pad.
170	60400	Plug for drip pan.
171	79100	Screw for wear plate for KPD-J pumps.
172	87200	Gasket for wear plate and adapter plate.
173	92500*	Adjustable screw for wear plate.

\* **Recommended spares for two year normal working**

I- Outline drawings with dimensions

- 1) Drg. No. TL 137-001-11 Sheet 1/2 & 2/2 Foot mounted pumps.
- 2) Drg. No. TL 137-005-14 Sheet 1/2 & 2/2 Centreline mounted pumps.

GENERAL OUTLINE DIMENSIONS OF KPD/KPDQF (FM) PUMPS  
 TL 137001 13

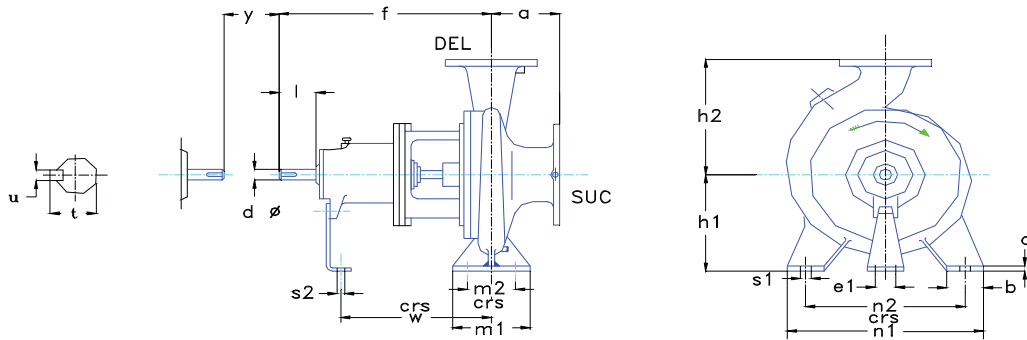

PUMP SIZE	DRIVING UNIT	PUMP DIMENSIONS				FOOT DIMENSIONS										SHAFT END																	
		DEL	SUC	a	f	h1	h2	b	c	m1	m2	n1	n2	w	s1	s2	e1	d $\phi$	l	t	u	y											
20/13 QF #	4	20	25	80	385	100	140	50	10	80	50	190	140	285	14	14	110	18	40	20.5	6	100											
20/16 QF #						132	150			100	70	210	160																				
20/20 QF #						160	170			240	190																						
25/16 QF #	5	25	40	100	385	132	165	50	14	100	70	210	160	285	14	15	110	24	50	27	8	100											
25/20 QF #		25	40	100		132	180			10	80	50	265										212	11.5									
32/13		32	50	80		112	140			190	140																						
32/16,32/16A						132	160					240	190																				
32/20,32/20A		40	65	100		160	180			210	160																						
40/13						112	140					240	190																				
40/16		40	65	100		132	160			240	190																						
40/20,40/20A						160	180			265	212																						
50/13		50	80	100		132	160			240	190																						
50/16,50/16A						160	180			265	212																						
50/20		50	80	100		160	200			265	212																						
65/13						65	100			160	180	65	125										95	280	212								
25/26		7	25	50		500	180			225	65	14	125										95	320	250	14	15	110	32	80	35	10	140
32/26			32	50			100			180	225																						
40/26	40		65	125	200		250	345	280																								
40/32					180		225	65	14	125	95			320	250																		
50/26	50		80	125	225		280	345	280																								
50/32					160		200	280	212																								
65/16	65		100	100	180		225	320	250	370	18																						
65/20					200		250	80	16	160				120	360	280																	
65/26,65/26N	80		125	125	180		225	65	14	125	95			320	250	14																	
80/16					225		250	345	280																								
80/20	80		125	125	225		280	400	315	18																							
80/26					200		280	80	16	160	120			360	280																		
100/20	100		125	200	280		360	280																									
65/32	9		65	100	530		225	280	80	16	160			120	400	315	370	18	15	110	42	110											
80/32		80	125	250		315	400	315																									
80/40,80/40N		80	125	140		280	355	80				16	160		120	435							355	370	18								
100/26						225	280	400				315																					
100/32		100	125	140		250	315	400				315																					
100/40						280	355	100				18	200		150	500							400	23									
125/26		125	150	150		250	355	80				16	160		120	400							315	18									
125/32						280	355	18				200	150		500	400							370	23									
125/40,125/40N		150	200	160		315	400	100				22	450																				
150/32,150/32N						315	400	22				450																					
150/40 \$		150	200	160		315	450	100				18	200		150	550							450	23									

# GENERAL OUTLINE DIMENSIONS OF KPD/KPDQF (FM) PUMPS

SHEET NO.2/2 TL 137001 13

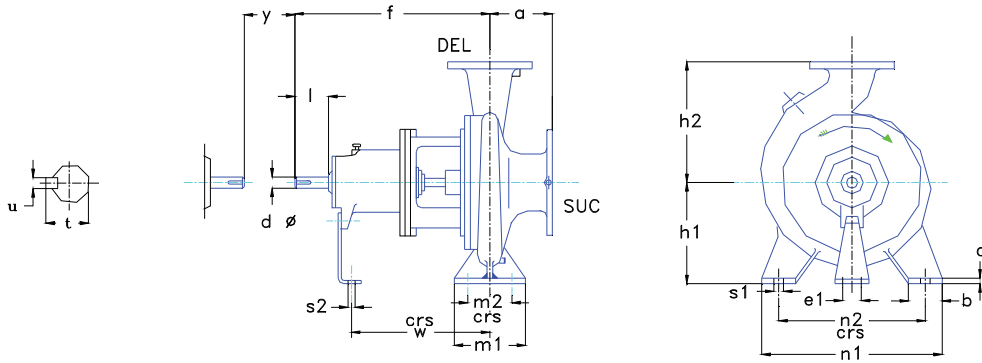

PUMP SIZE	DRIVING UNIT	PUMP DIMENSIONS				FOOT DIMENSIONS											SHAFT END								
		DEL	SUC	a	f	h1	h2	b	c	m1	m2	n1	n2	w	s1	s2	e1	d $\phi$	l	t	u	y			
100/40 *	11	100	125			280	355	100	18	200	150	500	400											180	
125/26 *						250	355	80	16	160	120	400	315											180	
125/32 *			125	150	140	670	280	355		18			500	400	500			19	140	48	110	51.5	14		140
125/40 *							315	400	100		200	150						23							140
150/32 *			150	200	160		315	400		22			550	450											140
150/52 \$	13	150	200	200	670	400	550	150	30	240	180	650	530	483	27	19	140	60	110	64.4	18			180	
200/38M \$			200	250	200	670	400	500	120	30	240	180	550	430	483.5	27	19	140	60	110	64.4	18			180
200/46 \$			200	250	200	670	425	550	120	30	240	180	640	540	483.5	27	19	140	60	110	64.4	18			180

\* THESE PUMPS CAN BE SUPPLIED IN UNIT-11 UNDER SPECIAL REQUIREMENT

# THESE PUMPS CAN BE PROVIDED WITH 'SEMI-OPEN' IMPELLER ONLY.

# GENERAL OUTLINE DIMENSIONS OF KPD(FM) PUMPS

TL 13799005 1

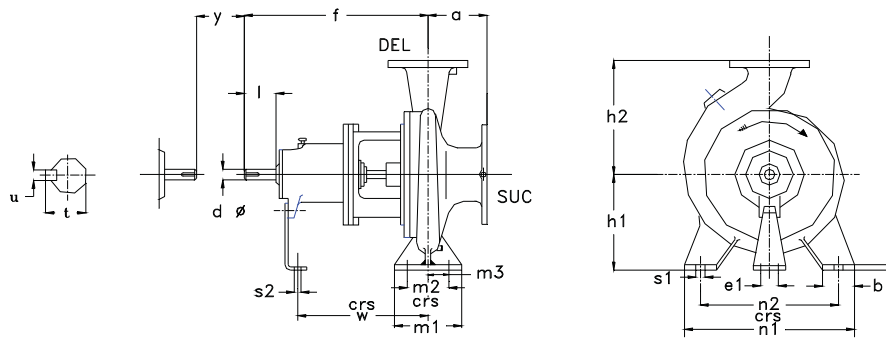

PUMP SIZE	DRIVING UNIT	PUMP DIMENSIONS										FOOT DIMENSIONS										SHAFT END				
		DEL	SUC	a	f	h1	h2	b	c	m1	m2	m3	n1	n2	w	s1	s2	e1	dφ	l	t	u	y			
125/45 \$	11	125	150	160	670	350	450	100	20	180	120	70	550	450	500	23	19	140	48	110	51.4	14	180			
150/43 \$	11	150	200	160	685	350	475	100	20	180	120	70	550	450	514	23	19	140	48	110	51.4	14	180			
65/43 \$	9	65	100	160	530	280	365	80	18	160	120	60	435	355	370	18	15	110	42	110	45	12	140			

NOTE:-

\$ THESE PUMPS SHALL NOT BE SUPPLIED WITH 'SEMI OPEN' IMPELLER.



**J- CONSOLIDATED TECHNICAL DATA:**

1. water fill capacity, speed, weight, solid size, specific speed, critical speed

SR NO.	PUMP SIZE	WATER FILL CAPACITY (LITER)	MAXIMUM ROTATIONAL SPEED(RPM)	WEIGHT APPROX. (Kg.)	MAX.SOLID SIZE (MM)	SPECIFIC SPEED		CRITICAL SPEED
						KPD	KPD-QF	
						(Ns METRIC)		
01	KPD 20/13QF	0.5	3500	31	1.8		52.08	12233
02	KPD 20/16QF	0.6	3500	38	2.0		34.91	9891
03	KPD 20/20QF	0.8	3500	43	2.25		27.34	7967
04	KPD 25/16QF	0.6	3500	36	1.5		36	8707
05	KPD 25/20QF	0.8	3500	44	2.1		47.2	7289
06	KPD 25/26A	1.7	3500	90	3.0	26.45		12771
07	KPD 32/13	0.8	3500	38	4.0	69.6	72.22	11555
08	KPD 32/16	1.0	3500	40	3.5	52.0	53.8	9653
09	KPD 32/16A	1.0	3500	40	3.5	52.56		
10	KPD 32/20	1.2	3500	47	3.5	38.2	40.96	12527
11	KPD 32/20A	1.2	3500	47	3.5	33.14		
12	KPD 32/26	1.8	3500	90	3.0	26.5	28.89	9101
13	KPD 40/13	1.1	3500	39	6.0	92.2	93.27	9275
14	KPD 40/16	1.2	3500	42	4.5	69.0	73.59	8460
15	KPD 40/20	1.5	3500	48	3.5	46.1	53.52	12050
16	KPD 40/20A	1.5	3500	48	3.5	47.9		
17	KPD 40/26	2.1	3500	90	3.5	37.6	36.99	8937
18	KPD 40/32	1.8	3500	103	4.5	25.85	31.9	7696
19	KPD 50/13	1.8	3500	42	11.0	127.5	130.14	7049
20	KPD 50/16	1.8	3500	46	9.0	93.8	96.76	6143
21	KPD 50/16A	1.8	3500	46	9.0	99.4		
22	KPD 50/20	2.1	3500	53	6.0	67.0	71.4	9319
23	KPD 50/26	3.9	3500	90	5.0	48.5	53.88	7748
24	KPD 50/32	4.5	3500	120	5.0	39.45	38.44	7446
25	KPD 65/13	2.4	3500	69	15.0	173.0	166.96	5230
26	KPD 65/16	2.8	3500	77	12.0	136.0	127.28	7477
27	KPD 65/20	3.1	3500	79	11.0	92.10	100.55	6687
28	KPD 65/26	4.2	3500	96	9.0	70.0	72.29	6326
29	KPD 65/26N	4.2	3500	96	9.0	66.0		
30	KPD 65/32	7.3	3500	140	8.0	56.9	54.45	8459
31	KPD 65/43	10.0	1750	195	15.0	34.68		6209
32	KPD 80/16	4.0	3500	85	18.0	155.5	165.92	5981
33	KPD 80/20	4.4	3500	86	15.0	121.0	119.66	5554
34	KPD 80/26	4.9	3500	116	12.0	85.80	86.44	5129
35	KPD 80/32	8.3	3500*	146	9.0	64.0	69.13	7993
36	KPD 80/40	11.0	1750	141	8.0	44.0	150.16	7572
37	KPD 80/40N	11.0	1750	141	8.0	51.0		
38	KPD 100/20	6.5	3500	106	20.0	154.5	153.29	4362
39	KPD 100/26	8.0	3500	134	17.0	108.2	113.27	6687
40	KPD 100/32	9.6	3500*	157	13.0	70.4	74.61	6808
41	KPD 100/40	13.8	1750	164	11.0	56.0	59.33	9936

42	KPD 125/26(UNIT 9)	12.0	1750	158	22.0	144.0	138.34	6415
43	KPD 125/26(UNIT11)	12.0	3500	190	22.0	144.0		6687
44	KPD 125/32	14.0	3500	179	17.0	89.40	97.31	10025
45	KPD 125/40	15.5	1750	212	14.0	71.82	68.3	
46	KPD 125/40N	15.5	1750	212	14.0	68.39		8598
47	KPD 125/45	17.0	1750	290	14.0	60.38		8540
48	KPD 150/32	18.0	1750	260	23.0	122.0		8295
49	KPD 150/32N	18.0	1750	260	23.0	119.0	134.5	
50	KPD 150/40	20.0	1750	285	14.0	95.15		4078
51	KPD 150/43	21.0	1750	300	14.0	73.1		7911
52	KPD 150/52	22.0	1750	435	15.0	124.25		19122
53	KPD 200/38M	25.2	1750	550	26.0	65.25		29139
54	KPD 200/46	27.5	1750	560	26.0	109.11		19282

## 2. GD<sup>2</sup> value

Sr. No.	Pump Type	Cl	Moment of Inertia of Complete Rotor Assembly		
			Dynamic Moment of Inertia Kgm-Sec2	Dynamic Moment of Inertia GD2 Kg m2	Dynamic Moment of Inertia GD2 Kg m2
			Br/St.St./ Sp. Mat.	Cl	Br/St. St./ Sp. Mat.
1.	KPD 20/13 QF	0.0000433	0.000051	0.00177	0.002
2.	KPD 20/16 QF	0.0001126	0.000127	0.00442	0.005
3.	KPD 20/20 QF	0.000270	0.00031	0.01061	0.012
4.	KPD 25/16 QF	0.00058	0.00067	0.023	0.026
5.	KPD 25/20 QF	0.000280	0.00032	0.01080	0.013
6.	KPD 25/26	0.0047	0.00537	0.185	0.210
7.	KPD 25/26A	0.0047	0.00537	0.185	0.210
8.	KPD 32/13	0.000315	0.00036	0.01236	0.014
9.	KPD 32/16	0.00084	0.00096	0.033	0.038
10.	KPD 3216A	0.00084	0.00096	0.033	0.038
11.	KPD 32/20	0.00199	0.00227	0.078	0.089
12.	KPD 32/20A	0.00199	0.00227	0.078	0.089
13.	KPD 32/26	0.0047	0.00537	0.185	0.21
14.	KPD 40/13	0.00042	0.00048	0.0184	0.0187
15.	KPD 40/16	0.00084	0.00096	0.033	0.038
16.	KPD 40/20	0.00199	0.00227	0.078	0.089
17.	KPD 40/20A	0.00199	0.00227	0.078	0.089
18.	KPD 40/26	0.005	0.0057	0.197	0.224
19.	KPD 40/32	0.011	0.0125	0.432	0.492
20.	KPD 50/13	0.00053	0.0006	0.0206	0.0236
21.	KPD 50/16	0.001	0.0012	0.041	0.047
22.	KPD 50/16A	0.001	0.0012	0.041	0.047
23.	KPD 50/20	0.0021	0.0024	0.082	0.094
24.	KPD 50/26	0.0059	0.0069	0.23	0.26
25.	KPD 50/32	0.011	0.0125	0.432	0.492
26.	KPD 65/13	0.00074	0.00084	0.029	0.033

27.	KPD 65/16	0.00126	0.0014	0.0494	0.055
28.	KPD 65/20	0.0028	0.0032	0.111	0.126
29.	KPD 65/26	0.0067	0.0076	0.263	0.30
30.	KPD 65/26N	0.0067	0.0076	0.263	0.30
31.	KPD 65/32	0.0132	0.0150	0.52	0.59

### 3. Hydrostatic Test Pressures

Nominal Impeller Dia (cm)	Pump size (Enclosed / Semi-open) KPD	Hydrostatic Test Pressures (Kg/cm <sup>2</sup> )	
		1450 RPM	2900 RPM
13	20, 32, 40, 50, 65/13	9	12
16	20, 32, 40, 50, 65, 80/16	10	15
20	20, 25, 32, 40, 50, 65, 80, 100/20	10	18
26	25, 32, 40, 50, 65, 80, 100, 125/26	12	16**
32	40, 50, 65, 80, 100/32	14	21**
32	125, 150/32	14	—
38	200/38M	17	—
40	80, 100, 125, 150/40	17	—
43	65, 150/43	17	—
46	200/46M	17	—
45	125/45	17	—
50	150/52	14	—

1. The above hydrostatic test pressures are irrespective of material of pump casing. The duration of hydrostatic test pressure shall be 2 minutes unless otherwise specified.

2. For stock order pumps, the maximum applicable test pressure for that pump size is applied.

3. The above test pressures are applicable for pumps operating on suction pressure up to 5kg/cm<sup>2</sup> (except for pumps marked with \*\* mark). For pumps with \*\* mark, the above test pressures are calculated without considering any suction pressure.

4. For higher suction pressures than those specified in note 3, hydrostatic test pressure should be calculated as given below:

Hydro test Pressure in (kg/cm<sup>2</sup> = 1.5 x (Max. working pressure experienced by pump casing corresponding to duty point impeller diameter, kg/cm<sup>2</sup>)

#### K- PRIME MOVER SELECTION:

In order to avoid continuous overloading of the electric motor, the rated power absorbed by the pump in kW should exceed the calculated power by the following percentage.

Required Power in kW	Power Margin
Upto 1.4 kW	30%
1.4 to 3.7 kW	25%
3.7 to 7.4 kW	20%
7.5 to 18.5 kW	15%
Over 18.5 kW	10%

**L- RECOMMENDED SPARES:**

**\* marked components in part description table are the recommended spares for two year normal working**

**M- PART OF O&M:**

**A. Temporary storage for up to six weeks.**

If the pump unit is not be used immediately it should be stored carefully in a horizontal position, in a sheltered, dry location. Additional rust preventive should be applied to all unpainted carbon steel or cast iron parts, and should not be removed until final installation.

**B. Long Term Storage.**

DO NOT place fingers or hands etc. into the suction or discharge pipe outlets and do NOT touch the impeller, if rotated this may cause severe injury. To prevent ingress of any objects, retain the protection covers or packaging in place until removal is necessary for installation. If the packaging or suction and discharge covers are removed for inspection purposes, replace afterwards to protect the pump and maintain the safety.

Fill the bearing housing with recommended oil to ensure that the shaft and bearings remain rust free.

**C. Exposed or Extreme Conditions Storage.**

For exposed storage or extreme variants in atmospheric or environmental conditions, please refer to KBL for special storage instructions to suit the conditions acceptable.

**D. loading / unloading**

**1. Transport.**

Pumps are dispatched in duly assembled condition. Lubricating oil in the bearing housing is drained prior to dispatch of pump. Pumps are protected against corrosion and packed for transport by normal road, rail and sea carriers.

**2. Handling**

When lifting the pump or pump set, use lifting equipment having a safe working load rating suitable for the weight specified. Use suitable slings for lifting any pump not provided with lifting points.

The use of suitable forklift truck and four chain crane sling equipment is recommended but locally approved equipment rating may be used.

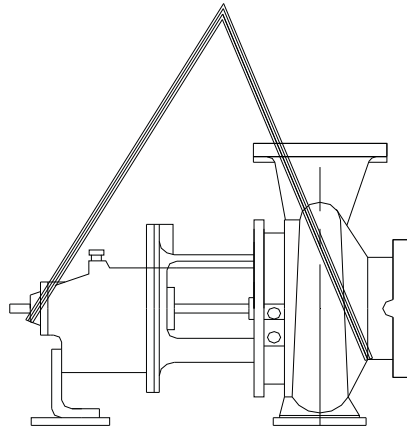

Pump should be slung as shown.

Pump set must be lifted from the lifting holes provided using suitable four chain lifting equipment.

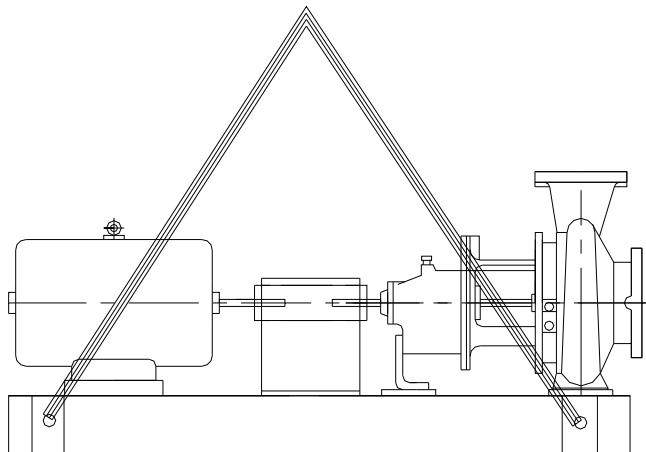

#### **N- QUALITY / INSPECTION /NDT REQUIREMENTS**

#### **O- PAINTING SPECIFICATIONS:**

##### **1. SURFACE PREPARATION**

- 1.1. Cleaning and preparation of the substrate must be of a high standard.
- 1.2. Prior to the application of this system the surface should be free from visible oil, grease and dirt and from mill scale, rust and foreign matter.
- 1.3. Whenever primer is not applied on the casting & cavities are filled by 'M' seal, such surface shall be cleaned by rough polish paper.
- 1.4. Casting shall be cleaned with washing thinner to remove the smudges of other paints, dust, dirt, sand.
- 1.5. Product is to be dried in the atmosphere or by compressed air before applying final paint.
- 1.6. Grease shall be applied before painting on name plate, arrow plate, machined faces, raised faces, protruded shaft portion.

## 2. PAINT SPECIFICATION

Following are the various paint types standardized for use to KBL make product.

2.1. Putty

2.2. Primers.

2.3 Final coats.

a. Synthetic based fast drying enamel paints against standard scope of supply.

b. Epoxy paints- only against the specific requirements against OA.

2.4. Type and shade of paint that are used as standard practice are given in chart 4.1 and 4.2 ( This shall be followed unless otherwise specified in order acceptance).

## 3. GENERAL PAINTING PROCEDURE:

a. Surface preparation shall be ensured as mentioned in (1).

b. One coat of paint is applied with spray gun.

c. Removing of paint and grease from name plates and re-touching of the areas got disturbed while cleaning.

d. All machined surfaces exposed are applied with grease /rust preventive KEMISOLV -'D' type or equivalent.

e. All couplings shall be painted with relevant color.

## 4. STANDARD PAINT TYPES AND SHADES

Based on pump type (Product wise) unless otherwise specified in O/A.

Sr. no.	Product	Paint Type	Procedure	Shade	Total D.F.T. microns (min)
1	All Pumps a) Inland	Special Synthetic Enamel fast drying	General	Water Blue	50
	b) Export	----- " -----		Water Blue	50
2	All Pumps	Epoxy	Epoxy	Light Grey	100
3	Domestic spares	Special synthetic Enamel fast drying	General	Water Blue	35
4	Products with only primer application	Primer as per end use	General	-	35

**P- DISPATCH**

The mechanical assembly comprises a rigid shaft, supported by a pair of bearings with a double / single shrouded impeller mounted in a removable bearing housing assembly. This is attached to an end suction volute casing fitted with wear rings. The bearing housing, shaft and impeller assembly can be withdrawn from the volute for maintenance without disconnection of pipe work. The complete assembly is of rigid construction, being intended for mounting on suitable base plate with electric motor / internal combustion engine. A suitable coupling is provided to transmit the rotational drive between pump and motor.

**Q- STANDARD SCOPE OF SUPPLY:**

1. Bare shaft pump with gland packed arrangement as 2 + L + 3.
2. For mechanical seal fitted pumps "cartridge seal" from the given list of seals will be supplied exclusively.
3. MOC shall be 01,02,08,09,10,11,60,72
4. Pump flanges drilled to ASA125 (FF) for CI and ASA150 (RF) for stainless steel with unstocked finish.
5. Pump will be supplied with stuffing box arrangement with plugged holes.
6. For gland packed pumps sealing shall be self-internal and for mechanical seal fitted pumps flushing shall be as per API 11.
7. Pump will be supplied with reinforced bearing arrangement.
8. Gasket will be supplied in Ferrolite NAM 37 or EQ MOC.
9. Gland packing will be supplied in CHAMPION 3116 or EQ.
10. Pump will be supplied with NPT tapping.
11. Oil lubricated bearings with constant level oiler to maintain the proper oil level in the bearing housing.
12. Pump will be supplied with clockwise direction of rotation when viewed from coupling end.

**R- INSTRUMENTATION**

**Following instrumentation is provided with pump against**

1. Temperature indicators
2. pressure gauges
3. API plan accessories