

OVERVIEW

Walchem's WDIS Series controller will reliably and economically control your water treatment disinfection process. The controller includes four standard sensor input options (free chlorine/bromine, chlorine dioxide, ozone, peracetic acid) or can be configured to use a variety of other types or ranges of Walchem disinfection sensors, such as hydrogen peroxide or total chlorine.

The WDIS Series controller takes the guesswork out of your disinfection process. The chemical concentration is continuously monitored and controlled to the precise range required for proper system control and regulatory compliance.

Designed to be flexible and versatile, the WDIS Series controller is the ideal solution for disinfection applications in cooling towers, food & beverage, drinking water, wastewater and swimming pools.

Integrated datalogging is available to validate system performance. A USB memory stick is all that's needed to extract data and event logs that include disinfection sensor measurements and relay status. Download log files from the USB stick to a PC at your convenience. It couldn't be easier!



SUMMARY OF KEY BENEFITS

- **Versatility for a Broad Range of Applications**
Choose from four standard industrial grade sensors in one controller (chlorine/bromine, chlorine dioxide, ozone, peracetic acid) or configure the controller to use a variety of other disinfection sensors. Relays can be configured for Hi Alarm, Low Alarm, Out-of-Range Alarm, In-Range Output or Probe Wash, providing unmatched flexibility.

- **Economical and Simple to Use**
WDIS controllers are economically priced and do not require any costly reagents. The rugged NEMA 4X enclosure and panel mounted flow assembly has only two process connections for quick and easy installation.

- **Built-in Safety Features**
Programmable output limit timers prevent run-away chemical addition. Digital Interlock Input may be used from a flow switch or level input to prevent chemical addition based on a stagnant sample, or control of an empty batch tank. The alarm relay notifies plant personnel of alarm conditions as soon as they occur.

- **Simple, Integrated Data Collection**
Download stored data from the controller to a USB stick. Use the data to simply and easily validate system performance, document compliance and reduce liability. The data and event logs show disinfection levels, as well as accumulated chemical feed and relay activation times.



WDIS410 Series | Disinfection Controllers

» Versatile relay configuration

- Control outputs can be set as high or low set points via keypad. Auxiliary outputs can be set as:
 - High alarm
 - Low alarm
 - In-range output
 - Probe wash
 - Out of range alarm

» Probe wash feature

- For applications that require frequent electrode cleaning, automatic probe wash extends the time between maintenance interruptions

» Programmable access code

- Secures set point parameters and prevents unauthorized use. Program any four digit access number or disable the code requirement.

» Display status at a glance

- Look at any set point without interrupting control or entering an access code. Top level view:
 - Analog graph relative to set point
 - Disinfection sensor values
 - Status of alarms, outputs

» Self diagnostics

- Software and electronics are constantly monitored without having to take the controller off-line. Any error messages are clearly displayed. A fifth relay is activated by any diagnostics failures.

» USB Flashstick Support

- Standard for data logs, event/relay and reset logs, and user configuration file import/export

Standard Disinfection Sensors | Free Chlorine/Bromine • Chlorine Dioxide • Peracetic Acid • Ozone

» Long-lasting amperometric electrode with rugged membrane

» Integrated temperature compensation

» Relatively insensitive to changes in sample flow rate

» Large openings in flow cell prevent clogging

» Excellent long-term stability

Free Chlorine /Bromine

Chlorine and Bromine are the most common disinfectants used in water treatment. They're readily available, inexpensive, and typically used in drinking water, swimming pools, cooling towers and process water applications.

Chlorine Dioxide

Chlorine dioxide is a very strong oxidant that is often used for disinfection in drinking water, food & beverage, and cooling tower applications. It's preferred for some uses since it doesn't affect the taste and odor of the water being treated.

Peracetic Acid

Peracetic acid has been used for decades as a disinfectant in the food & beverage industry. Its use has grown to many other applications including bottling, CIP (Clean In Place), laundry, pulp & paper, and agriculture.

Ozone

Ozone is the strongest oxidant used in water treatment. It is commonly used in drinking water (disinfection, oxidation, taste and odor control), food & beverage, swimming pools (therapy pools), zoos and aquariums.

USB Features

» Integrated datalogging collects analytical measurements at 10 minute intervals and captures all relay activations.

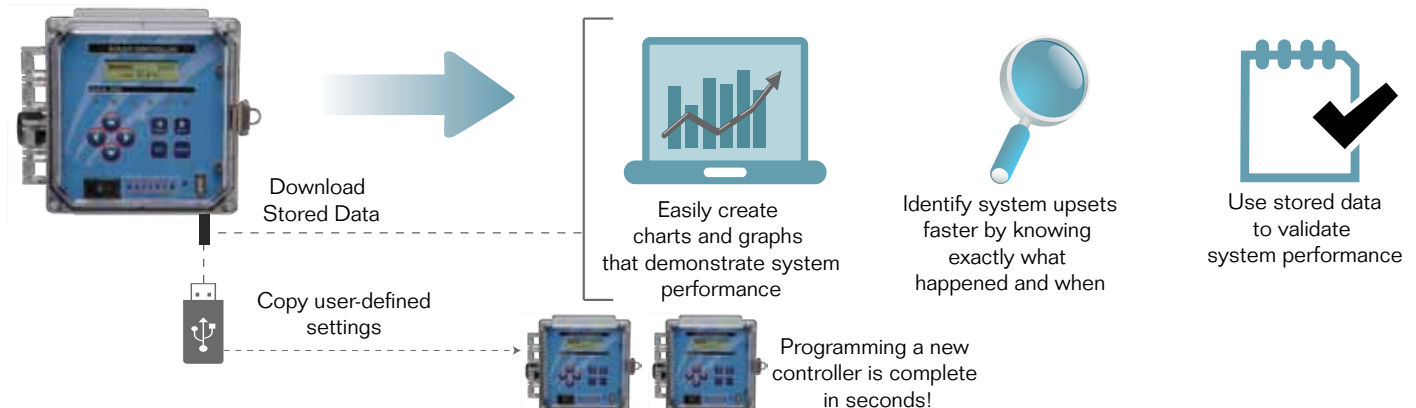

Dimensions

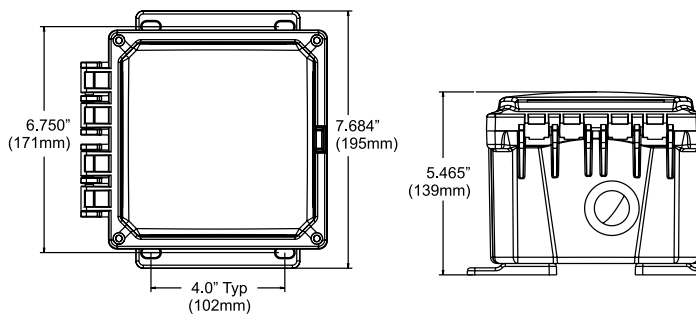

Inputs

Input Power 100-240 VAC, 50/60 Hz, 8A
Fuse: 1.0 ampere, 5 x 20 mm

Input Signals

Sensor ±2000 mV

Interlock (Optional)

Isolated, dry contact closure required
(i.e. flow, level)

Mechanical (controller)

Enclosure Polycarbonate
NEMA Rating NEMA 4X (IP65)
Display 2 x 16 character backlit liquid crystal
Ambient Temperature 32 to 122°F (0 to 50°C)
Shipping weight 7 lbs (3 kg) (approximately)

Outputs

Control 1, Control 2 (On/Off)

Two internally powered relays
6A (resistive), 1/8 HP

All relays are fused together as one group, total current for this group must not exceed 6A

Control 3, Control 4, Alarm

Dry contact relays
6A (resistive), 1/8 HP

4-20 mA 1 or 2 (optional)

Internally powered, Fully isolated
600 Ohm max resistive load
Resolution .001% of span
Accuracy ± 1% of reading

Sensor Power ±5VDC, 5 mA

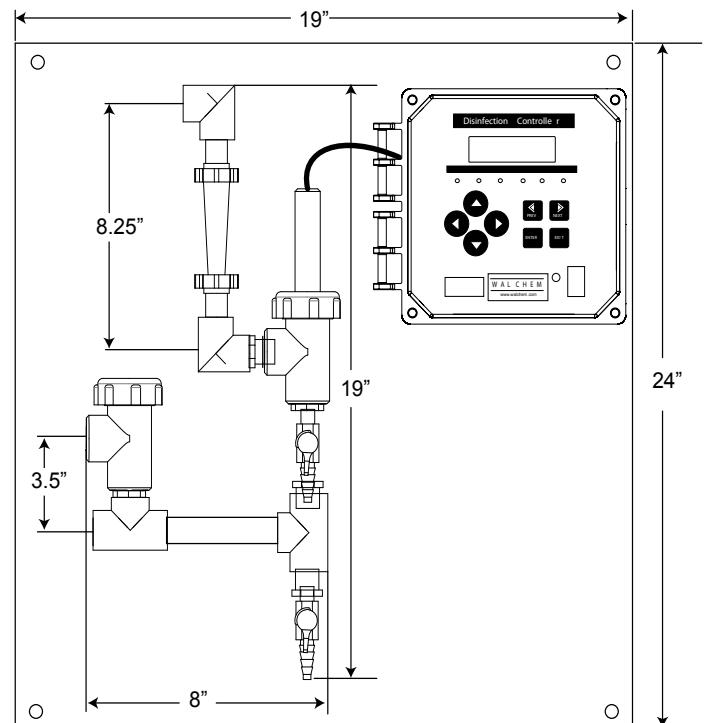

Sensor Specifications

Mechanical

Operating Temperature Chlorine Dioxide, Peracetic Acid, Ozone:
0 to 50°C (32 to 122°F)
Chlorine/Bromine: 0 to 45°C (32 to 113°F)
Operating pressure 0 to 1 atm (0 to 14.7 psi)
Storage temperature 0 to 50°C (32 to 122°F)
Shelf life 1 year
Flow cell inlet 1/4\" NPTF
Flow cell outlet 1/4\" NPTF

Electrical

Power requirements ±5 VDC, 5 mA maximum
Signal 0 to -2000 mVDC
Max cable length 305 m (1000 ft)
Cable required 2 twisted pair, 24 AWG shielded,

Materials of Construction (Sensor)

Sensor Body PVC, Polycarbonate
Membrane Chlorine Dioxide, Peracetic Acid,
Ozone: Silicone
Chlorine/Bromine: PTFE
Flow cell body Isoplast
O-ring FKM

	Chlorine Dioxide	Peracetic Acid	Ozone	Free Chlorine/Bromine	Free Chlorine/Bromine Extended pH Range
Range	0-16.75 mg/l	0-1675 mg/l	0-16.75 mg/l	0-13.25 mg/l	0-12.50 mg/l
Resolution	0.01 mg/l	1 mg/l	0.01 mg/l	0.01 mg/l	0.01 mg/l
Cross sensitivity	Free chlorine (5%), Ozone		Free chlorine (5%)	Ozone, ClO ₂	Ozone, ClO ₂
Flow rate of sample	30 to 100 liters/hr (7.9 to 26.4 gallons/hr)				
pH range of sample	1.0 to 11.0	1.0 to 7.0	2.0 to 11.0	6.8 to 8.0	4.0 to 12.0
Conductivity range of sample	50 to 10,000 μS/cm			Up to 4% NaCl	50 to 10,000 μS/cm
Response time	30 seconds	3 minutes	30 seconds	30 seconds	2 minutes

ORDER INFORMATION

WDIS410 —
 voltage output sensor USB

VOLTAGE

1 = 120 VAC, prewired w/ USA power cord & 6" pigtails
 5 = Hardwired, cable glands

OUTPUT

N = No data output
 4 = One (1) Isolated 4-20 mA output
 2 = Two (2) Isolated 4-20 mA outputs

SENSOR (consult factory for other sensor types & ranges)

N = No sensor
 1 = Free chlorine/bromine sensor with flow cell & 20 ft. cable
 2 = Chlorine dioxide sensor with flow cell & 20 ft. cable
 3 = Ozone sensor with flow cell & 20 ft. cable
 4 = Peracetic acid sensor with flow cell & 20 ft. cable
 5 = Free chlorine/bromine sensor with flow manifold & 5 ft. cable on panel
 6 = Chlorine dioxide sensor with flow manifold & 5 ft. cable on panel
 7 = Ozone sensor with flow manifold & 5 ft. cable on panel
 8 = Peracetic acid sensor with flow manifold & 5 ft. cable on panel
 A = Free chlorine/bromine sensor, extended pH range with flow cell & 20 ft. cable
 B = Free chlorine/bromine sensor, extended pH range with flow cell & 5 ft. cable on panel

USB FEATURES

U = Integrated datalogging, event/reset logging, and configuration file import/export

Note: Refer to the Disinfection Sensor brochure for additional sensor options. Order the WDIS controller with sensor option "N" then order the appropriate sensor separately.

AGENCY CERTIFICATIONS

UL ANSI/UL 61010-1:2004, 2nd Edition*
 CAN/CSA C22.2 No.61010-1:2004 2nd Edition*
 CE Safety EN 61010-1:2001 2nd Edition*
 CE EMC EN 61326-1:2006

Note: For EN61000-4-6 & EN61000-4-3 the controller met performance criteria B.

*Class A equipment: Equipment suitable for use in establishments other than domestic, and those directly connected to a low voltage (100-240 VAC) power supply network which supplies buildings used for domestic purposes.



Webmaster®ONE

WebMasterONE is the most advanced online cooling tower and boiler controller in the water treatment industry. The flexible multi-I/O platform allows you to control multiple cooling towers, boilers, closed loops, and condensate lines with just one controller. An extensive assortment of integrated communications and data handling features are included that enable water treatment professional to provide more effective water management services to their customers.



Metering Pumps

The E-Class is the most innovative and comprehensive metering pump product line in the world. Over 50 years of pump experience and a commitment to superior mechanical design has led to development of many industry firsts, including 360 stroke-per-minute technology, IP67 waterproof construction, and the world's highest capacity solenoid metering pumps.



WIND WebMaster® Industrial Water Controllers

Walchem's WebMaster Industrial (WIND) Controller sets a new standard for Industrial Water Treatment Controllers. WIND has a flexible multi-I/O platform, a wide range of analytical sensor measurement capabilities, and an extensive assortment of integrated communications and data handling features.



WebAlert® Remote Monitor

Walchem's WebAlert is the first stand alone remote monitoring device that can web enable your installed equipment without having to replace or upgrade it.

ABOUT US

Walchem integrates its advanced sensing, instrumentation, fluid pumping and communications technologies to deliver reliable and innovative solutions to the global water treatment market

Our in-house engineering is driven by quality, technology and innovation. For more information on the entire Walchem product line, visit: www.walchem.com



Walchem, An Iwaki America Incorporated Company
 Five Boynton Road Hopping Brook Park
 Holliston, MA 01746 USA
 Phone: 508-429-1110
 Fax: 508-429-7433
www.walchem.com