



Enriching Lives

HORIZONTAL AXIALLY SPLIT-CASING PUMPS

TYPE- iHT



CE

KIRLOSKAR BROTHERS LIMITED

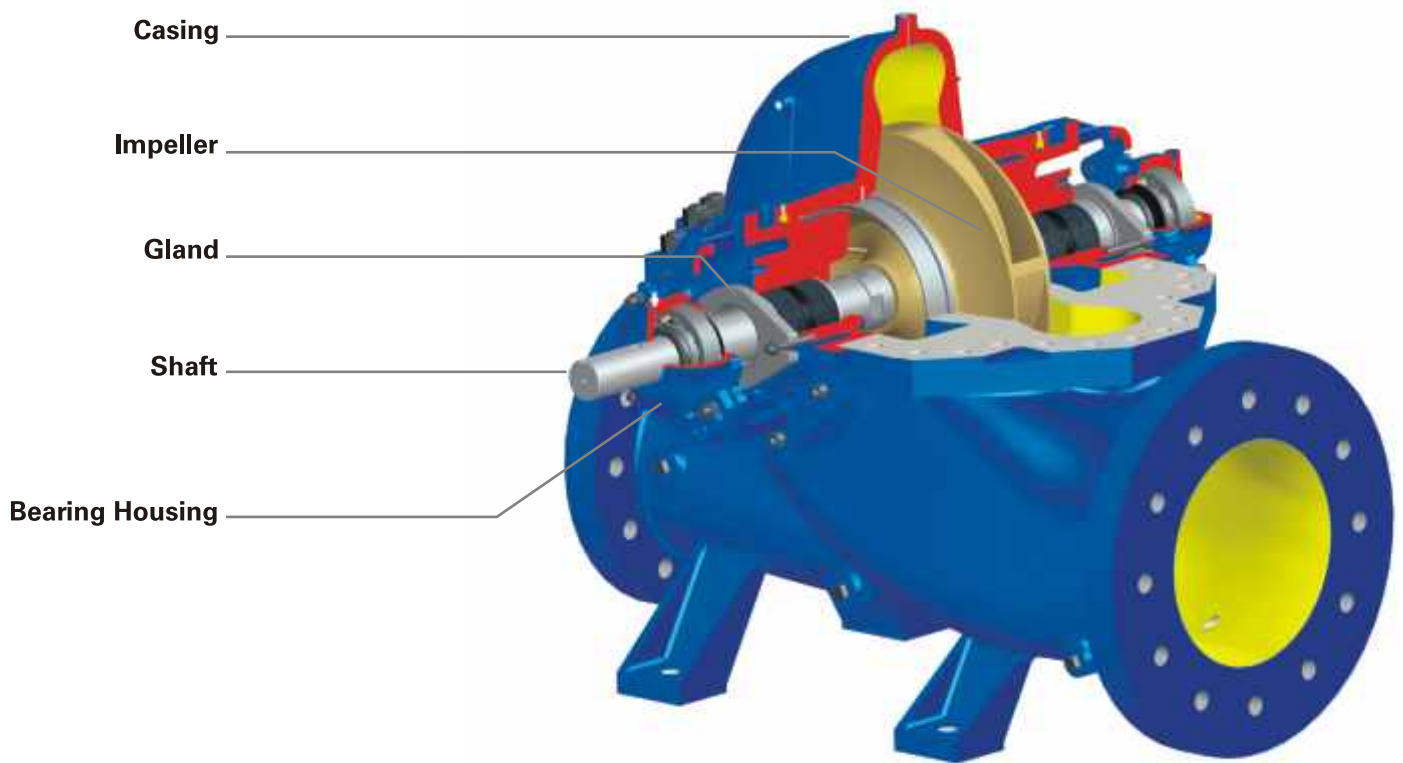

RANGE

Delivery size up to 300 mm

Capacity up to 1300 m³/hr

Head up to 250 metres

APPLICATIONS

Suitable for handling water with slight impurities in Industries, Water Works, Irrigation, Sprinkler Irrigation, Fire-fighting, Air Conditioning Plants, Water Circulation, Processing Plants. Primary and Secondary HVAC application, Cooling tower, Desalination

CONSTRUCTIONAL FEATURES

These are horizontal axially split casing, single stage/double stage suction or single suction pumps with horizontal shaft and fitted with DIN 24960 cavity mechanical seal. These new generation pumps are designed for externally removable type bearing housing, DIN 24960 Cavity mechanical seal, Impeller nut and sleeve arrangement, Easy wear ring Fitment. Variety of models are available to operate to 50Hz.

- Direct or gear drive
- Suitable for higher working pressures
- Rotating assembly available for inspection or maintenance by removing only upper half casing without disturbing suction and delivery piping and motor
- Pump axis horizontal
- Highest hydraulic and overall efficiency due to latest design and manufacturing techniques
- Very high efficiency in the operating range
- Good suction performance and low NPSH
- Stable characteristics
- Minimum maintenance required
- Vibration free performance
- Highest reliability

Pump Casing :

Horizontal axially split volute type, suction and discharge nozzles and supporting feet are cast integral with lower half casing.

Impeller :

The Impeller is centrally placed on a sturdy designed shaft and the entire rotating assembly is dynamically balanced to provide a smooth trouble free longer and efficient operation.

Shafts :

The high tensile steel shaft accurately machined and ground is supported by antifriction bearings. The shaft is protected by shaft sleeves from wear in stuffing box area.

Stuffing Box :

Can be sealed by gland packing or by mechanical seal and is suitable for liquids having temperature from (-) 8°C to 90°C. In special cases packing or mechanical seal can be offered upto 120°C.

Bearings :

Deep groove ball bearings are provided. Standard lubrication is grease.

Direction Of Rotation :

Standard : Clockwise viewed from driving end.

Optional : Anticlockwise viewed from driving end.

Drive :

Suitable for coupling with electric motors, I.C. engines or steam turbines either directly or through belt drives.

Flanges :

Standard : Drilled to BS : 4504 PN 16 F. F. For single stage pumps

Drilled to BS : 4504 Pn40 for double stage pumps

HIGH SPEED PUMPS - iHT SERIES : USER BENEFITS

This series is a combination of two stage and single stage pumps with single suction or double suction impeller. This series can be used for hot and cold water for higher heads. Ideally suitable in different sectors for various application.

Application

i-HT pumps are used in different sectors for different applications such as

Building Sector

For multistoried buildings, air conditioning plants, sprinkler system.

Water resource management

For desalination plants, water supply and water treatment.

Irrigation

For small and large lift irrigation scheme. Sprinkler irrigation

Industry

For utility, circulation, cooling tower, process water etc.

Since all i-HT pumps are of 2pole and mechanical seal version it helps in all above sector to make pleasant work environment and compact pump house. (Two stage pump will be offered in gland packed version as a standard scope and mechanical seal version as optional where as single stage will be offered strictly in mechanical seal version only and no option of gland packed)

Innovative Features

User Benefits

Simplicity in wearing ring fitment :

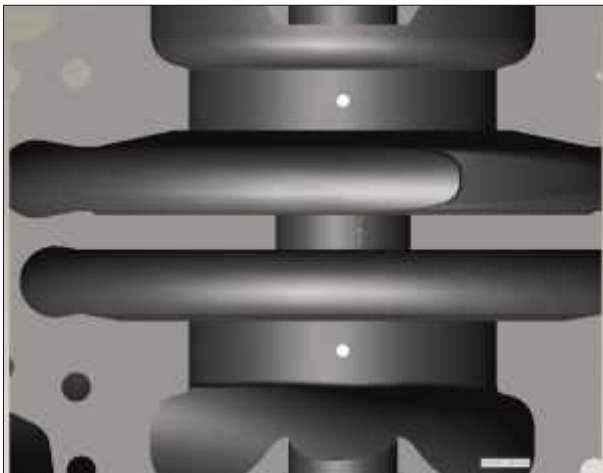

Conventional way
(Top view lower half casing)

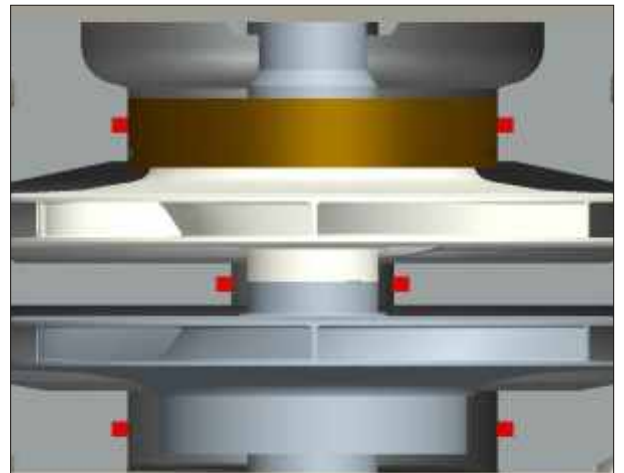

innovative way
(Top view lower half casing)

- Easy assembly and dismantling due visualization.
- No skill required for casing ring fitment.
- Reduction in down time.

Easy bearing removal

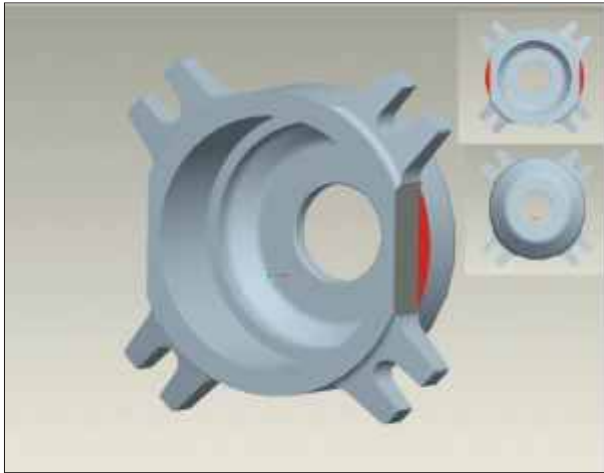

Conventional way
(Top view lower half casing)

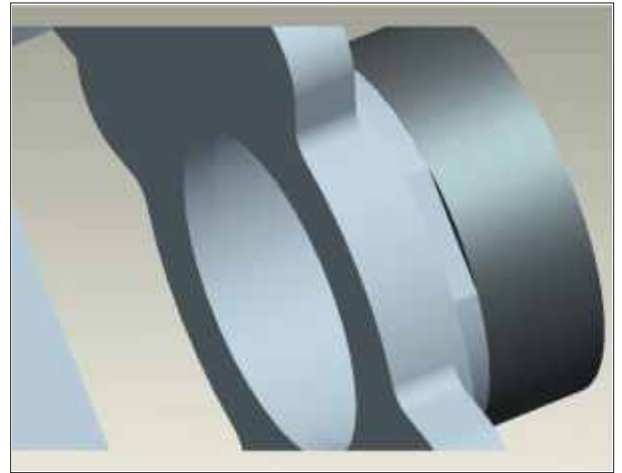

innovative way
(Top view lower half casing)

Provision for pull- bearing housing and bearing

- No need to remove upper half casing.
- No need to take rotating unit out.
- Use the puller to remove the housing.
- Use the puller and remove the bearing.
- Saves 2-3 assembly hours and down time.

Mistake proof assembly of two stage impeller



First stage

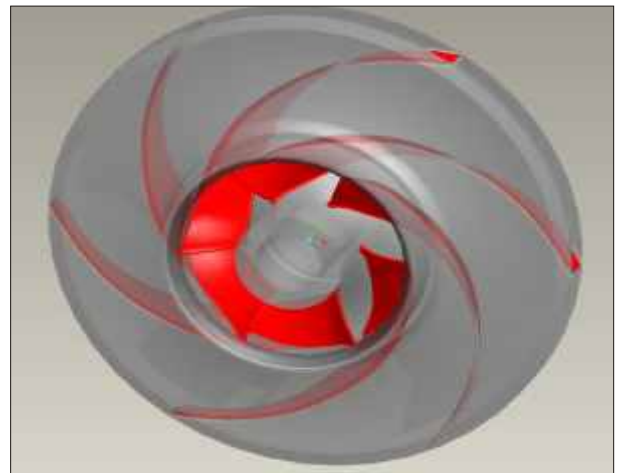

Second stage impeller

HIGH SPEED PUMPS - iHT SERIES : USER BENEFITS

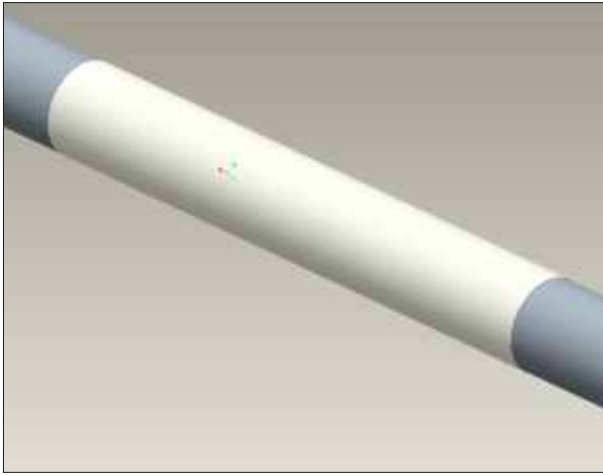

Conventional shaft

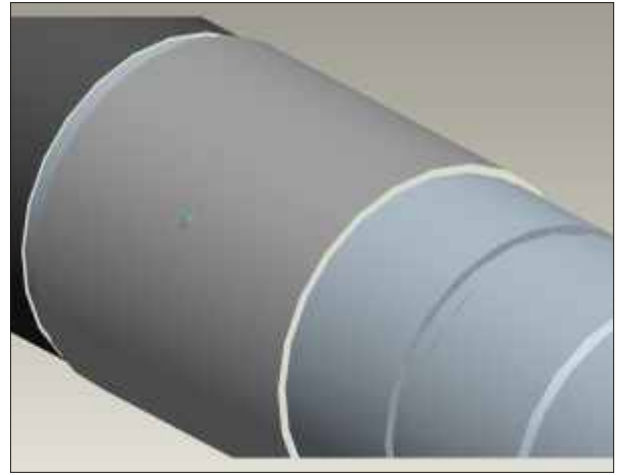

Innovated shaft

- First stage and second stage impeller fitting dimensions differ.
- Mistake of interchangeability is totally eliminated in assembly.
- No skill or hydraulic expertise required at assembly due to pokayoke.
- This will reduce 10-12 hrs of rework time in case if mistake is happened.

Grease filling frequency reduction



Existing CI bearing housing and innovated engineering plastic bearing housing

- UHMWPE plastic material is used in iHT series pumps.
- It is light weight and excellent resistance to any corrosion due to weather condition.
- Good in heat dissipation resulting in maintaining lower temp in bearing housing.
- Reduces the frequency of grease refill.

HIGH SPEED PUMPS - iHT SERIES : USER BENEFITS

Pleasant work environment

- -All pumps single stage pumps are with DIN 24960 cavity mechanical seal (For two stage pump it is optional supply)
- Mechanical seals are internally fixed in the insert cavity.
- API plan 11 is used.
- No leakage due to mechanical seal will help for a pleasant working environment.

Assembly time is drastically reduced due to innovative sleeve and nut arrangement

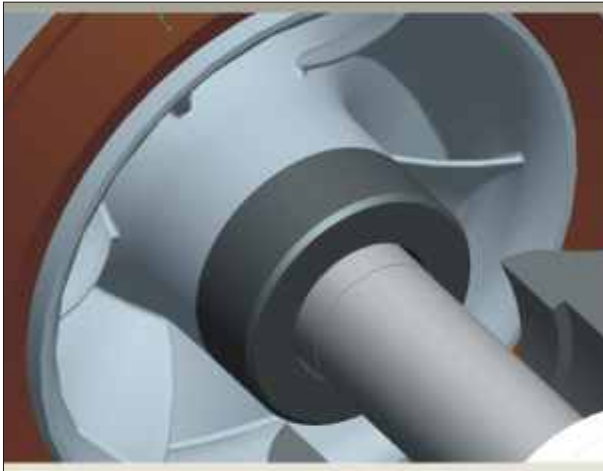

Conventional method of impeller and nut arrangement

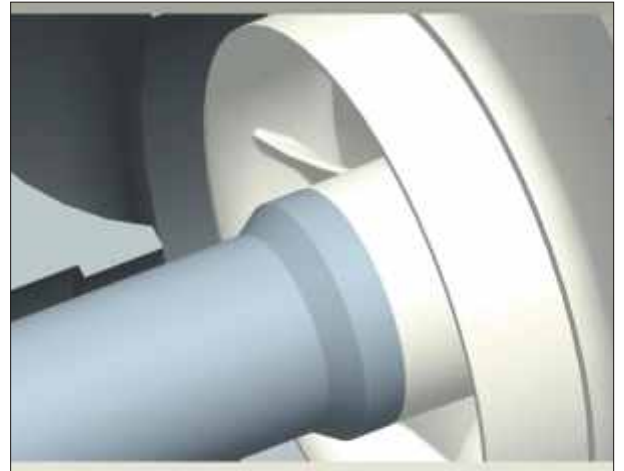

Conventional method of impeller and Sleeve arrangement.

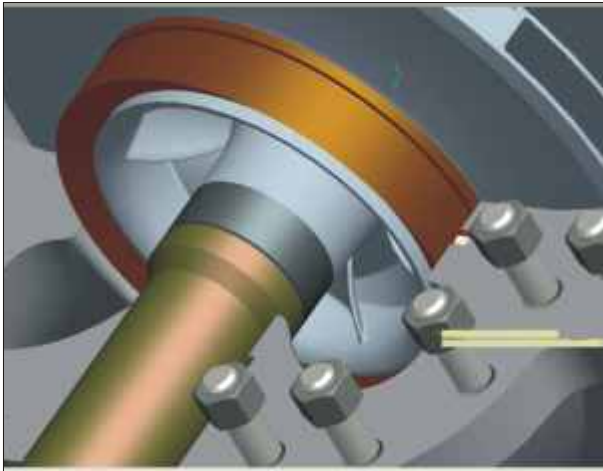

Innovative method of impeller, nut and sleeve arrangement.

User Benefits

- Worn out sleeve can be replaced w/o disturbing the impeller assembly.
- No need of special skill for assembly since impeller remain intact to its position.
- No need to refer drawings or dimensions for assembly
- No change in hydraulic performance since impeller remained correctly in position in hydraulic passage.

Even though the pumps are running at 3000 rpm and above due to robust constructions vibrations are limited per HIS standard.

HIGH SPEED PUMPS - iHT SERIES : CUSTOMER BENEFITS

iHT series is Split-case thru-bore pump series with innovative features. This series of pumps are basically designed for 2900 rpm and above speed.

These series is a combination of two stage and single stage pumps with single suction or double suction impeller. This series can be used for hot and cold water for higher heads. Ideally suitable in water works, for circulation of water in air conditioning plants, power stations, drainage, lift irrigations.

Energy efficient pump

The hydraulic matching of the pump impeller and casing was achieved by utilizing Computational Fluid Dynamics (CFD). Basic 14 single stage models with different 26 impellers and five two stage models result in a product offering superior performance, better efficiency and lower NPSHR even at high speed resulting in lower energy cost

Compact in Size

Because of its higher speed these pumps are compact in size as compared to conventional split-case pump of four or six pole. With this it will lower the size or will reduce the no of impellers or it will have lower size impeller.

- Because of compact in size it will save few sq meter space of pump house which will reduce initial investment in sector like Building.
- Being a lower in delivery size initial installation and piping cost will be reduced.

Elimination of separate standby engine set



Dual drive two stage pump

- Two stage pump in this series will be supplied with dual drive
- Pump can be rotate CW or CCW as per the demand at site without any modification /change at site.
- Same pump can be connected to motor and engine at a time by clutch arrangement .
- Stand by pump can be eliminated.

GENERAL DIMENSIONS / MOUNTING DETAILS

SINGLE STAGE (MODULE 1, 2, 3)

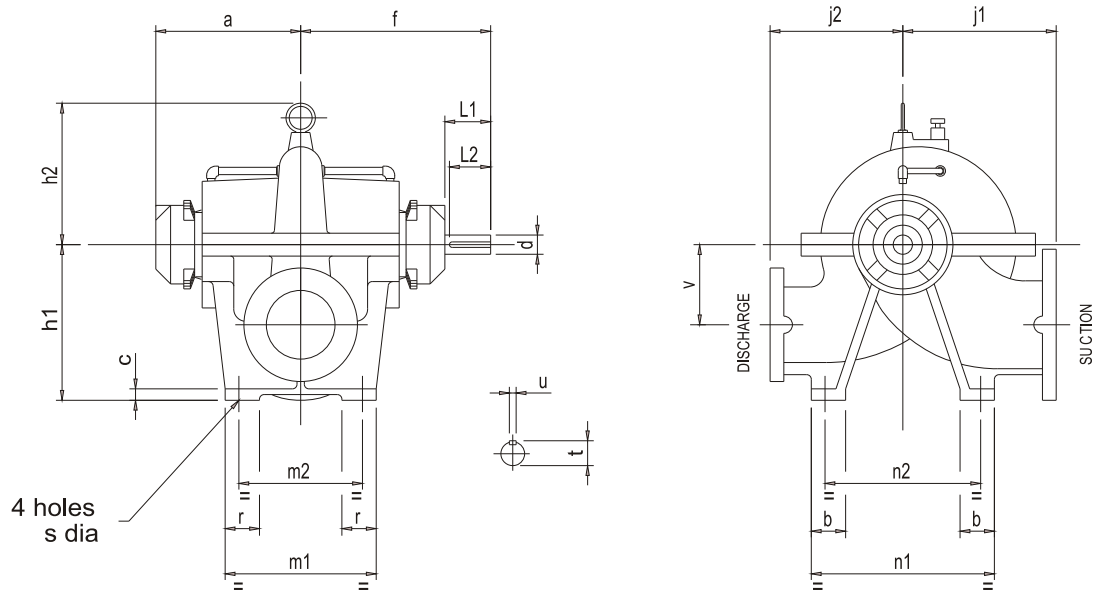

PUMP TYPE	BRANCHES SUCT	BRANCHES DISCH	a	f	h1	h2	j1	j2	v	m1	m2	n1	n2	b	c	r	s	t	u	D-tol	L1	L2	MASS KG	FLANG DRILLING
i-HT06BA	80	65	264,5	313,5	250	245	280	225	130	300	240	350	290	65	25	65	22	31	8	28j6 $\begin{matrix} +0.009 \\ -0.004 \end{matrix}$	70	63	120	BS4504PN16
i-HT08BA																								
i-HT08BD	100	80	264,5	313,5	280	249	270	230	130	300	240	350	290	65	25	65	22	31	8	28j6 $\begin{matrix} +0.009 \\ -0.004 \end{matrix}$	70	63	137	BS4504PN16
i-HT08BE																								
i-HT10DE	125	100	264,5	313,5	320	299	320	275	170	300	240	350	290	65	25	65	22	31	8	28j6 $\begin{matrix} +0.009 \\ -0.004 \end{matrix}$	70	63	180	BS4504PN16
i-HT12CA																								
i-HT12CF	150	125	264,5	313,5	340	293	310	290	160	300	240	350	290	75	25	75	22	31	8	28j6 $\begin{matrix} +0.009 \\ -0.004 \end{matrix}$	70	63	194	BS4504PN16
i-HT12CG																								
i-HT10BA																								
i-HT10BD	150	100	326	401	340	308	310	250	170	300	240	350	290	75	25	75	22	45	12	42k6 $\begin{matrix} +0.018 \\ +0.002 \end{matrix}$	102	89	180	BS4504PN16
i-HT10BE																								
i-HT10ED	125	100	326	401	340	346	340	350	190	330	270	450	390	75	25	75	22	45	12	42k6 $\begin{matrix} +0.018 \\ +0.002 \end{matrix}$	102	89	245	BS4504PN25
i-HT12BA																								
i-HT12BD	150	125	326	401	340	295	350	250	180	330	270	400	340	75	25	75	22	45	12	42k6 $\begin{matrix} +0.018 \\ +0.002 \end{matrix}$	102	89	180	BS4504PN16
i-HT12BE																								
i-HT12BF																								
i-HT12DA	150	125	326	401	340	309	335	290	175	330	270	400	340	75	25	75	22	45	12	42k6 $\begin{matrix} +0.018 \\ +0.002 \end{matrix}$	102	89	265	BS4504PN16
i-HT12DF																								
i-HT12EA	150	125	326	401	390	380	400	350	210	330	270	470	390	85	25	75	22	45	12	42k6 $\begin{matrix} +0.018 \\ +0.002 \end{matrix}$	102	89	340	BS4504PN25
i-HT15BA																								
i-HT15BE	200	150	326	401	390	304	365	310	200	330	270	400	340	75	25	75	22	45	12	42k6 $\begin{matrix} +0.018 \\ +0.002 \end{matrix}$	102	89	306	BS4504PN16
i-HT15DA																								
i-HT15DF	200	150	326	401	440	359	365	315	235	420	360	420	340	85	25	75	22	45	12	42k6 $\begin{matrix} +0.018 \\ +0.002 \end{matrix}$	102	89	330	BS4504PN16
i-HT20DD																								
i-HT20DE	250	200	402	496	540	381	450	385	285	500	440	530	450	85	25	75	22	59	16	55m6 $\begin{matrix} +0.030 \\ +0.011 \end{matrix}$	127	100	465	BS4504PN16
i-HT20ED	250	200	402	496	460	410	480	420	225	420	350	550	440	110	28	90	27	59	16	55m6 $\begin{matrix} +0.030 \\ +0.011 \end{matrix}$	127	100	530	BS4504PN25

GENERAL DIMENSIONS / MOUNTING DETAILS

TWO STAGE (i-HT12XD, i-HT15XE, i-HT15XF)

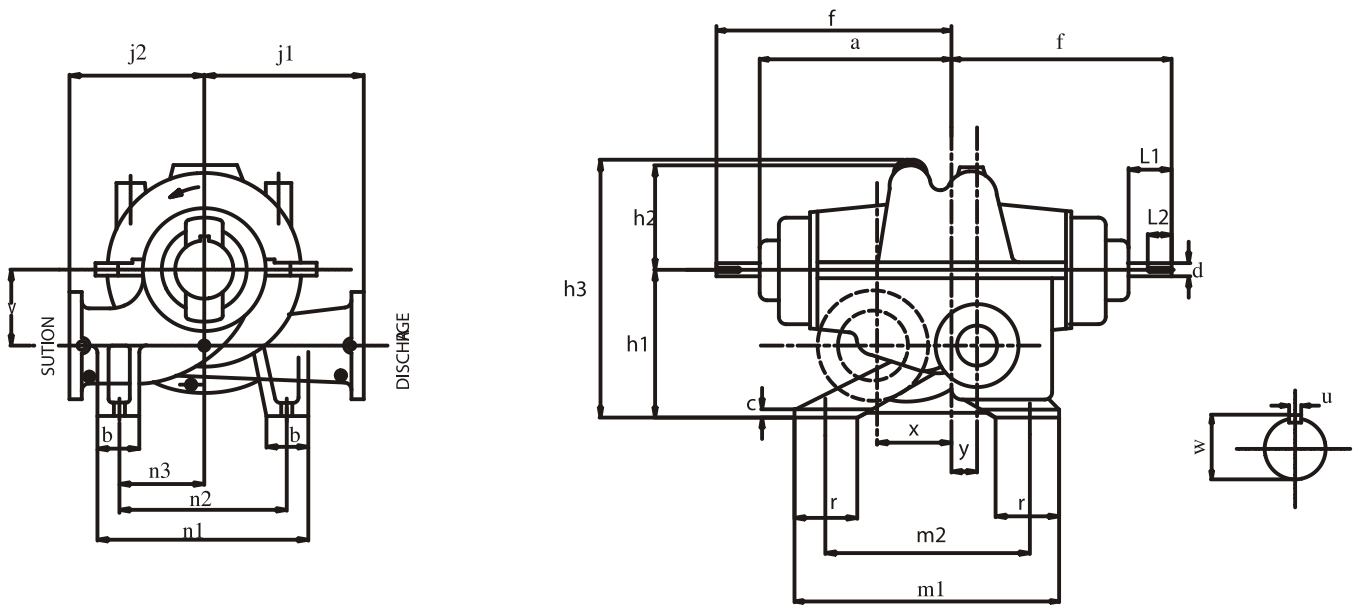

PUMP	a	f	h1	h2	h3	j1	j2	v	m1	m2	n1	n2	n3	x	y	b	c	r	d	w	u	L1	L2	mass (kg)
i-HT12XD	535	650	400	265	695	350	450	180	480	420	540	430	265	135	50	110	24	110	50	53.5	14	100	80	590
i-HT15XE i-HT15XF	535	650	400	290	730	400	500	180	480	420	620	510	300	110	50	110	24	110	50	53.5	14	100	80	640

TWO STAGE (i-HT05AA, i-HT06AA)

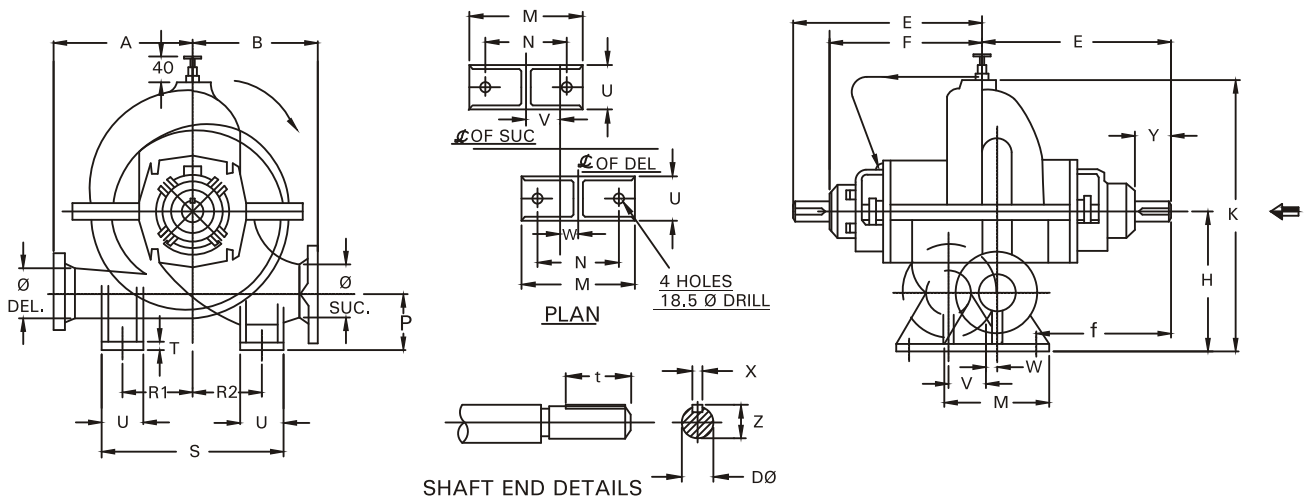

PUMP	SUC Ø	DEL Ø	A	B	E	F	H	K	M	N	T	P	R1	R2	S	U	V	W	X	Y	DØ	f	Z	t	Wt. IN Kg
i-HT05AA	80	50	225	225	400	332	230	430	160	120	16	105	122.5	122.5	325	80	65	30	8	70	30	310	33	67	118
i-HT06AA	100	65	250	250	435	367	260	500	200	150	20	115	135	135	350	80	65	33	10	72	38	327	41	65	164

CROSS SECTIONAL VIEW i-HT PUMP SINGLE STAGE (MECHANICAL SEAL)

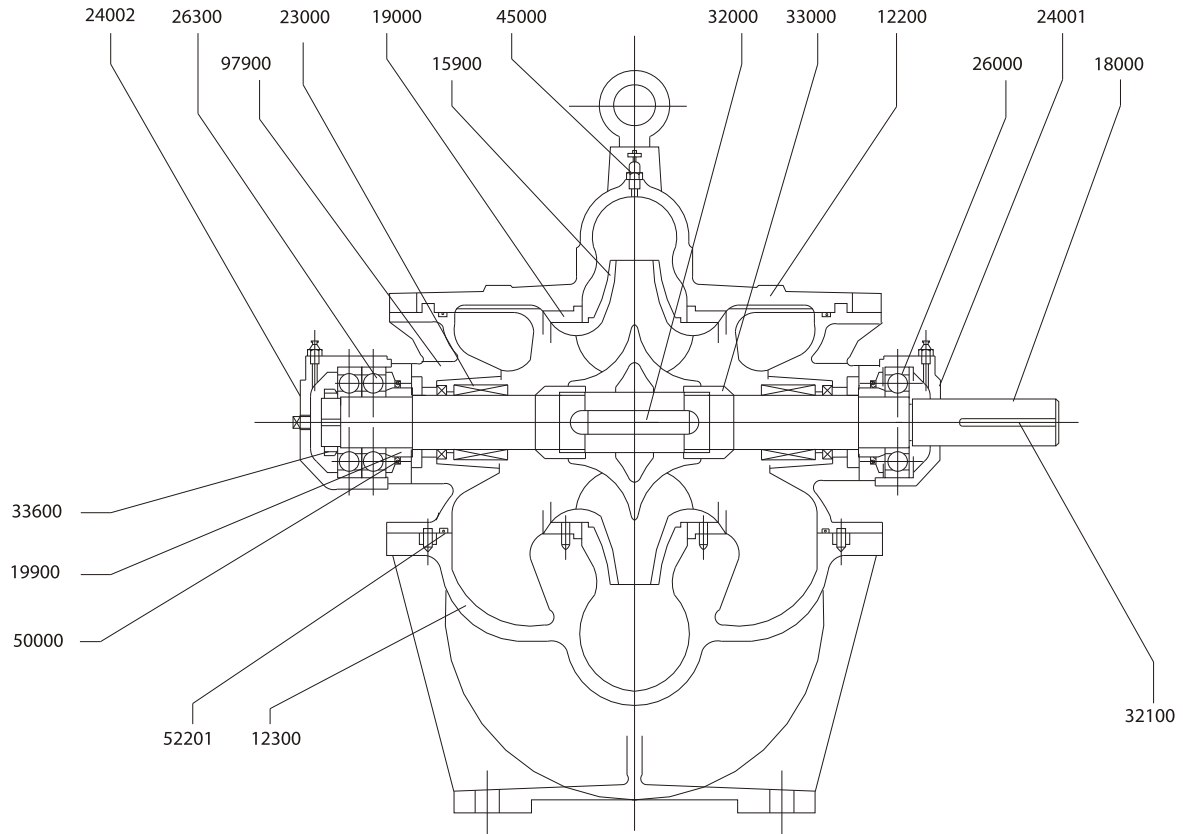

PART NO	DESCRIPTION	QTY
12200	UPPER HALF CASING	01
12300	LOWER HALF CASING	01
15900*	IMPELLER	01
18000*	SHAFT	01
19000*	WEAR RING	02
19900	SHOULDER RING	02
23000	MECHANICAL SEAL	02
24001	BEARING HOUSING DE	01
24002	BEARING HOUSING NDE	01
26000	BEARING	02
26200	ANGULAR CONTACT PAIRED BRG.	02
32000*	IMPELLER KEY	01
32100*	KEY FOR COUPLING	01
33000*	IMPELLER NUT	02
33600*	LOCK NUT FOR BEARING	01
45000	VENTVALVE	01
50000*	OIL SEAL	02
52201*	"O" RING FOR INSERT	02
97900	INSERT	02

CROSS SECTIONAL VIEW i-HT PUMP TWO STAGE i-HT12XD, i-HT15XE, i-HT15XF

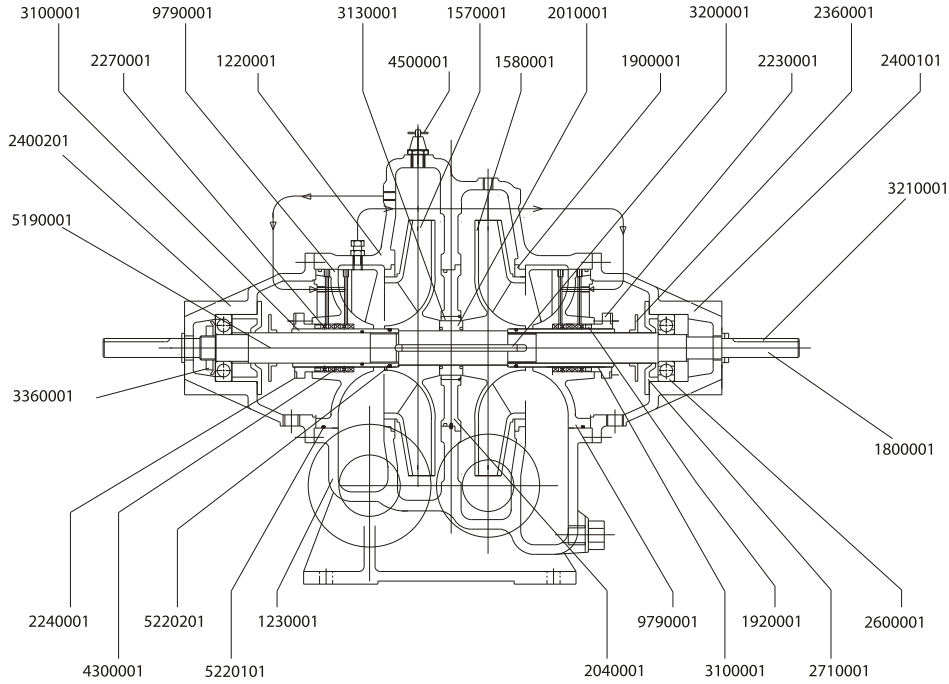

PART NO	DESCRIPTION	MATERIAL DESCRIPTION	QTY
12200	UPPER HALF CASING	CI IS 210-FG 260	01
12300	LOWER HALF CASING	CI IS 210-FG 260	01
15700*	IMPELLER I STAGE	CI IS 210-FG 260	01
15800*	IMPELLER II STAGE	CI IS 210-FG 260	01
18000*	SHAFT	ST ST ASTMA 276-431 ANLD	01
19000*	WEAR RING	CI IS 210-FG 260	02
19200	NECK RING	CI IS 210-FG 260	02
20100*	SPACER BETWEEN IMPELLER	CI IS 210-FG 260	01
20400*	INTERSTAGE RING	CI IS 210-FG 260	01
22300*	GLAND	CI IS 210-FG 260	02
22400*	GLAND PLATE	MS IS 2062 -Fe 410W A	02
22700*	LANTERN RING	CI IS 210-FG 260	02
23600*	WATER DEFLECTOR	RUBBER	02
24001	BEARING HOUSING DE	CI IS 210-FG 260	01
24002	BEARING HOUSING NDE	CI IS 210-FG 260	01
26000	BEARING	STEEL	02
27100	BEARING COVER	CI IS 210-FG 260	02
31000*	SHAFT SLEEVE	LT BR IS 318-LTB2	02
31300*	INTER STAGE BUSH	LT BR IS 318-LTB2	01
32000*	IMPELLER KEY	ST ST ASTMA 276-410 ANLD	01
32100*	KEY FOR COUPLING	CS IS 1570 - 40C8 HOT RLD	01
33600*	LOCK NUT FOR BEARING	CS IS 1570 - 20C8 HOT RLD	01
43000*	GLAND PACKING	CHAMPION-3116 OR EQ	01
45000	VENTVALVE	RLD-BRASS IS 319 GR 1	01
51900	GASKET	NON ASBESTOS	01
52201*	"O" RING FOR INSERT	NEOPRENE RUBBER	02
52202*	"O" RING FOR SLEEVE	NEOPRENE RUBBER	02
97900	INSERT	CI IS 210-FG 260	02

CROSS SECTIONAL VIEW i-HT PUMP TWO STAGE i-HT05AA, i-HT06AA

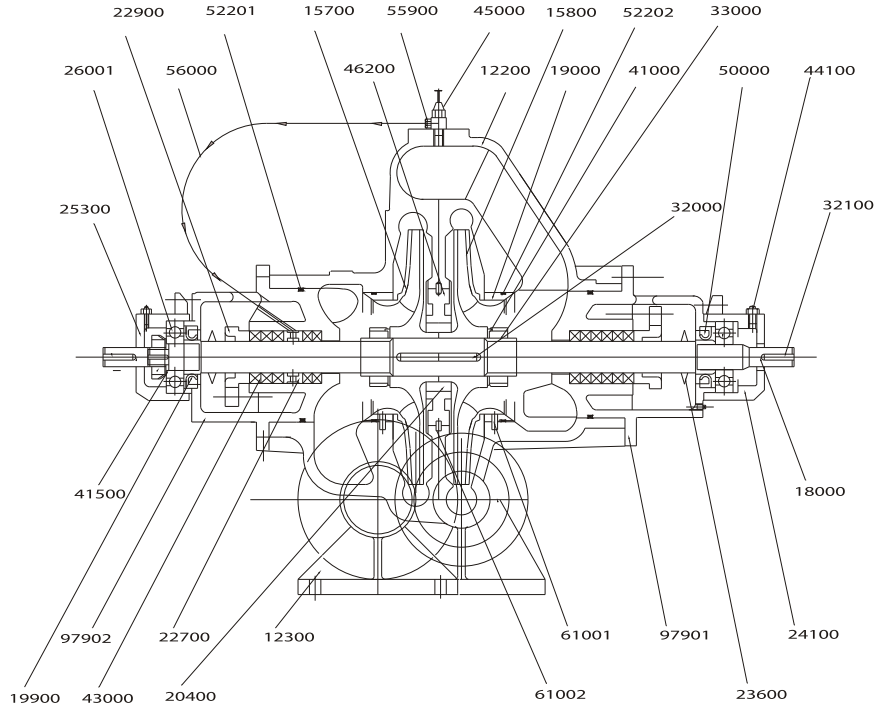

PART NO	DESCRIPTION	MATERIAL CONSTRUCTION	QTY
12200	CASING HALF UPPER	CI IS 210-FG 260	01
12300	CASING HALFLOWER	CI IS 210-FG 260	01
15700*	IMPELLER I STAGE	CI IS 210-FG 260	01
15800*	IMPELLER II STAGE	CI IS 210-FG 260	01
18000*	PUMP SHAFT	ST ST ASTM A 276-431 ANLD	01
19000*	WEAR RING	CI IS 210-FG 260	02
19900	SHOULDER RING	CI IS 210 GR FG 200	02
20400*	INTERSTAGE RING	CI IS 210-FG 260	01
22700*	LANTERN RING	CI IS 210-FG 260	01
22900	GLAND	CI IS 210-FG 260	02
23600*	LIQUID DEFLECTOR	NATURAL RUBBER	02
24100	BRG. CARTRIDGE DE	CI IS 210-FG 260	01
25300	BRG. CARTRIDGE NDE	CI IS 210-FG 260	01
26000*	DEEP GROVE BALL BEARING	STEEL	01
32000*	KEY FOR IMPELLER	ST ST ASTM A 276-410 ANLD	02
32100*	KEY FOR COUPLING	CS IS 1570 GR 40 C8	01
33000*	IMPELLER NUT	LT BR IS 318 GR LTB2	02
41000	LOCK WASHER	CS IS 1570 GR 10 C4	01
41500	LOCK WASHER	CS IS 1570 GR 10 C4	01
43000*	GLAND PACKING	CH. STYLE 3116 OR EQ.	01
44100	GREASE NIPPLE	IS 1367 CL. 4.6 CDP	02
45000	VENT VALVE	RLD-BRASS IS 319 GR 1	02
46200	INTERSTAGE DIAPHRAGM	CI IS 210-FG 260	01
50000	OIL SEAL	NEO.RUBBER ST. SPRING	02
51900*	GASKET BETN. HALVES	NON ASBESTOS	02
52201	"O" RING	NATURAL RUBBER	02
52202	"O" RING	NATURAL RUBBER	02
55900	STUD COUPLING	ROLLED BRASS	02
56000	SEALING TUBE	NYLON	01
61001	PIN FIR CASING RING	CS IS 1570 GR 40 C8	02
61002	PIN FOR INTERST. DIAPHRAM	CS IS 1570 GR 40 C8	01
97901	INSERT DE	CI IS 210 GR FG 260	01
97902	INSERT NDE	CI IS 210 GR FG 260	01

FAMILY CURVES

FAMILY CURVE FOR i-HT SERIES (Split case series with innovative features)

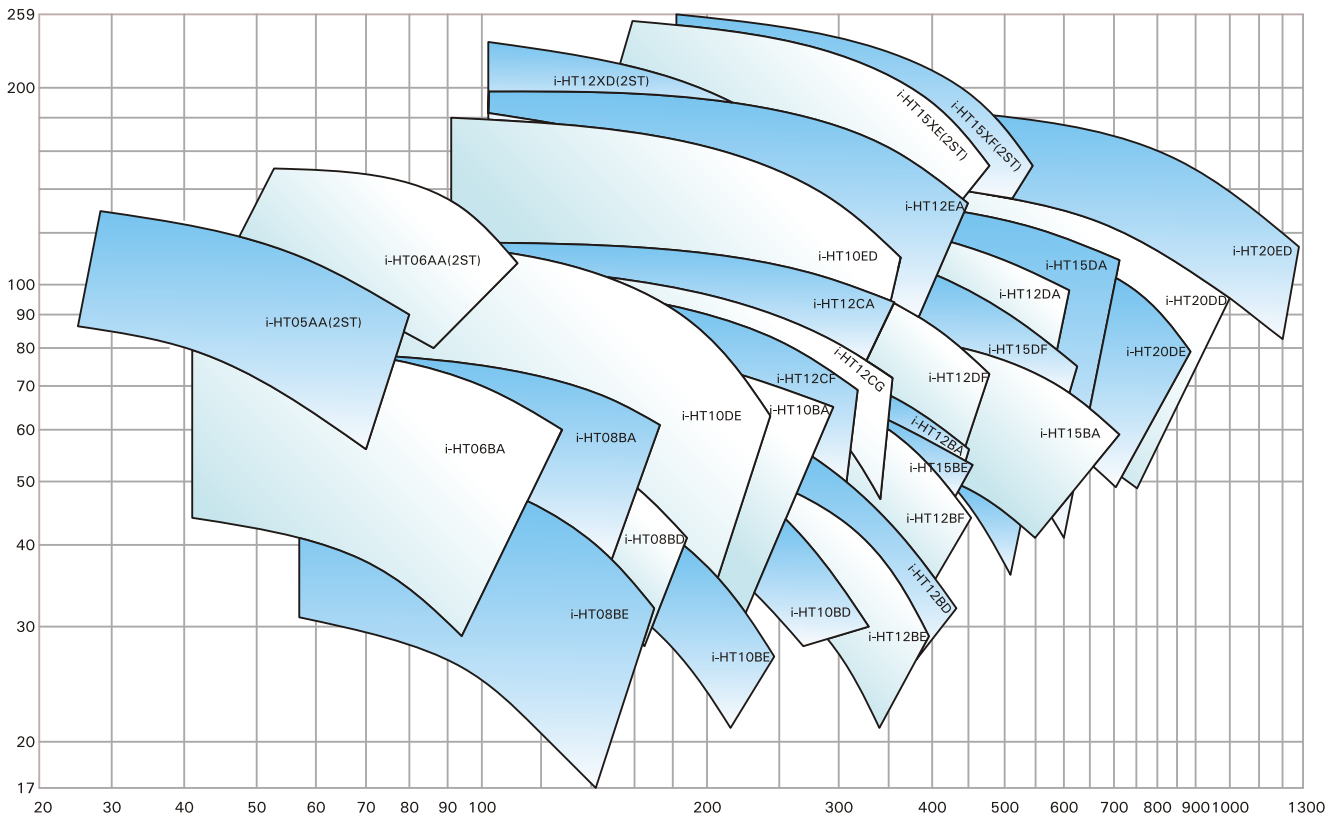

Note: 1) i-HT05AA, i-HT06AA, i-HT12XD, i-HT15XE, i-HT15XF ARE TWO STAGE PUMPS
 2) MAXIMUM FLOW IS TAKEN UPTO 8Mtr NPSHR

MATERIALS

MATERIAL OF CONSTRUCTION

Casing Half Upper / Lower	Cast Iron / Cast Steel / Stainless Steel / Duplex Steel
Impeller	Cast Iron / Bronze / Phosphor Bronze / Cast Steel / Stainless Steel / Chrome Steel / Duplex Steel
Wear Ring	Cast Iron / Bronze / Steel
Shaft	Carbon Steel / Stainless Steel / Duplex Steel
Shaft Sleeve	Stainless Steel / Bronze

MATERIAL STANDARDS - GENERAL INFORMATION

Material Type	Indian Standard (IS)	American standard (ASTM)	DIN
Cast Iron			
Cast Iron	IS 210 Gr. FG 260	ASTM A48 Class 40	(0.6025)DIN 1691 GG25
Spheroidal Graphite Cast Iron			
SG Iron (Ductile Iron)	IS 1865 Gr 400/15	A536, 60-40-18	(0.7040)DIN1693 GGG40
SG Iron (Ductile Iron)	IS 1865 Gr 500/7	A536, 65-45-12	(0.7050)DIN1693 GGG50
Carbon steel			
Carbon steel (Wrought)	IS 1570 (part II) Gr. 40C8	ASTM A107 Gr. 1040	(1.1186)C40E/CK40
Carbon steel (Wrought)	IS 1570 (part II) Gr. 20C8	ASTM A107 Gr. 1020	(1.0402)C22
MS Steel	MS IS 2062 - Fe 410 W A	ASTM-A283 GR.D	DIN 1700 GR ST4-2 FABRICATED STEEL44
Cast Steel Grades			
Cast steel		ASTMA 216 Gr. WCB	1.0619(GS-C25)
Cast Stainless Steel			
Stainless Steel CF8M	IS 3444 Gr. 4	ASTMA 351 Gr. CF8M	1.4408(GX5CrNiMo19-11-2)
Stainless Steel CF8M	IS 3444 Gr. 4	ASTMA 743 Gr. CF8M	1.4408(GX5CrNiMo19-11-2)
Stainless Steel CF3M	IS 3444 Gr. 16	ASTMA 351 Gr. CF3M	1.4409(GX2CrNiMo19-11-2)
Stainless Steel CF3M	IS 3444 Gr. 16	ASTMA 743 Gr. CF3M	1.4409(GX2CrNiMo19-11-2)
Stainless Steel CF8	IS 3444 Gr. 1	ASTMA 351 Gr. CF8	1.4301(X5CrNi18-10)
Stainless Steel CF3	IS 3444 Gr. 15	ASTMA 351 Gr. CF3	1.4306(X2CrNi19 11)
Cast Chromium StainlessSteel			
Stainless Steel CA15	IS 3444 Gr. 10	ASTMA 217 Gr. CA15	1.4106&1.448(DIN17445 GX12Cr14)
Stainless Steel CA15	IS 3444 Gr. 10	ASTMA 743 Gr. CA15	1.4106&1.448(DIN17445 GX12Cr14)
Stainless Steel CA6NM	IS 3444 Gr. 24	ASTMA 487 Gr. CA6NM	1.4313&1.4317(GX5CrNiMo13-4)
Stainless Steel CA6NM	IS 3444 Gr. 24	ASTMA 743 Gr. CA6NM	1.4313&1.4317(GX5CrNiMo13-4)
Chromium StainlessSteel Round Bar Matterial			
Stainless steel 410	IS 1570 (part V) Gr. X12Cr12	ASTMA 276 type 410	1.4006(X10Cr13)
Stainless steel 420	IS 1570 (part V) Gr. X20Cr13	ASTMA 276 type 420	1.4021(X20Cr13)
Stainless steel 431	IS 1570 (part V) Gr. X15Cr16Ni2	ASTMA 276 type 431	1.4057(X20CrNi17)
Stainless steel 316	IS 1570 (part V) Gr. X04Cr17Ni12Mo2	ASTMA 276 type 316	1.4401(X5CrNiMo17122)
Stainless steel 316L	IS 1570 (part V) Gr. X02Cr17Ni12Mo2	ASTMA 276 type316L	1.4404(X2CrNiMo1810)
Cast Duplex Steel			
Duplex Steel 1A		ASTMA 890 Gr. CD4MCu	25Cr-5Ni-Mo-Cu
Duplex Steel 2A		ASTMA 890 Gr. CE8MN	24Cr-10Ni-Mo-N
Duplex Steel 3A		ASTMA 890 Gr. CD6MN	25Cr-5Ni-Mo-N
Super Duplex steel 4A		ASTMA 890 Gr. CD3MN	25Cr-7Ni-Mo-N
Super Duplex steel 5A		ASTMA 890 Gr. CE3MN	24Cr-10Ni-Mo-N
Non Ferious Materials			
Bronze	IS 318 Gr. LTB2 (CuSn5Zn5Pb5C)	ASTMB 584 - C90500	DIN 1705 Rg 5
Phosphor Bronze	IS 28 Gr. 1 (CuSn11PC)		
Zinc Free Bornze	IS 28 Gr. 1 (CuSn10C)		

KIRLOSKAR BROTHERS LIMITED

NO. HA17H25AA0-0

PERFORMANCE CURVE OF PUMP i-HT20DE

SUC. 250 mm DEL 200 mm

THIS CURVE RELATES TO LIQUID OF SP.GR. = 1.0

n = 2950 rpm
(NOMINAL)



Enriching Lives

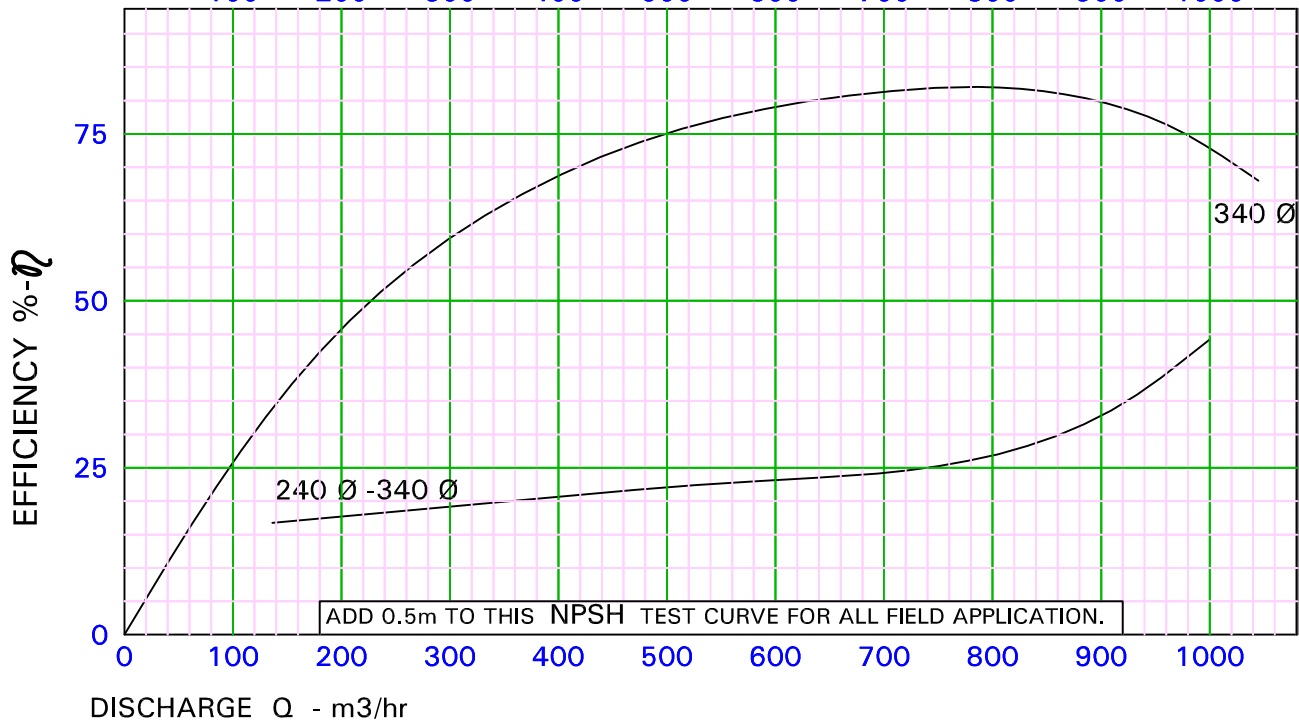
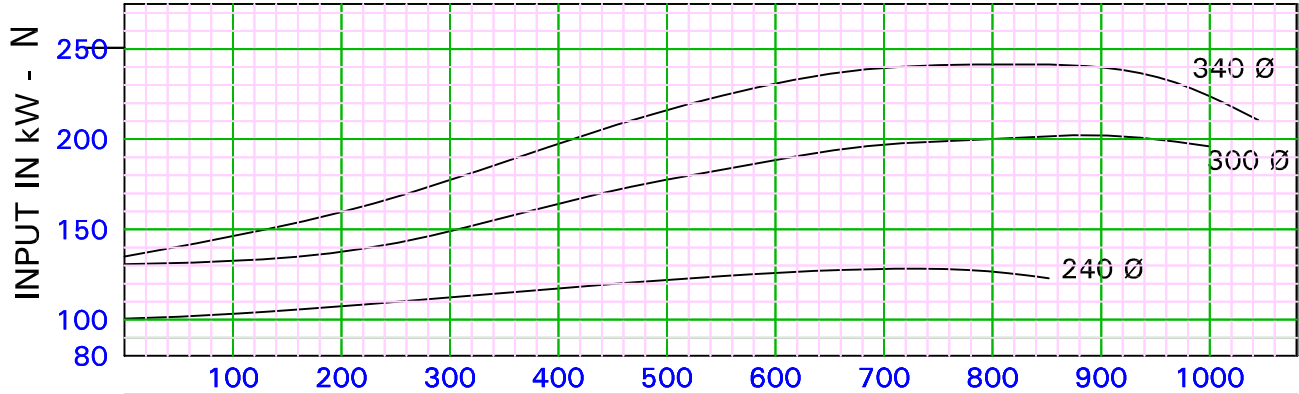
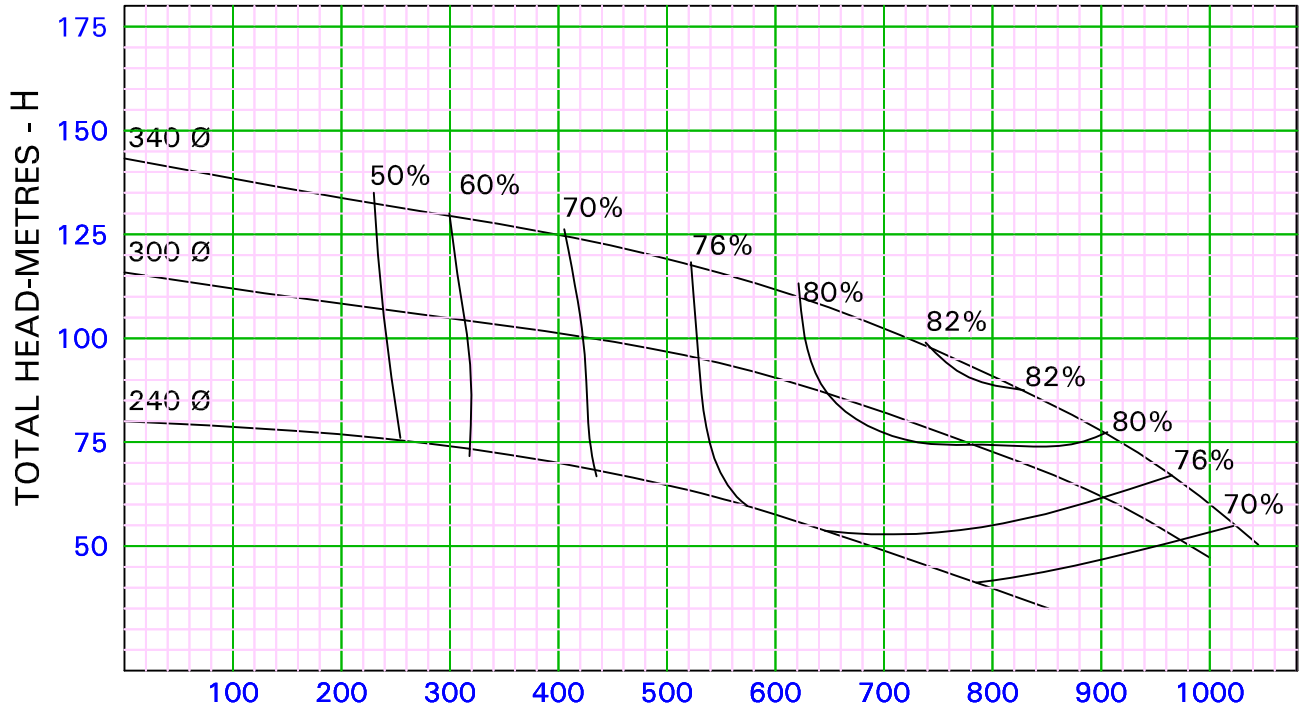

DISCHARGE Q - m3/hr

RECOMMENDED DELIVERY PIPE SIZE mm	200Ø	250Ø	300Ø	350Ø	
RECOMMENDED SUCTION PIPE SIZE mm	250Ø	300Ø	350Ø	400Ø	450Ø

KIRLOSKAR BROTHERS LIMITED

NO. HA17H24AA0 0

PERFORMANCE CURVE OF PUMP *i*-HT20DD

SUC. 250mm DEL 200 mm

THIS CURVE RELATES TO LIQUID OF SP.GR. = 1.0

n = 2960 rpm
(NOMINAL)



Enriching Lives

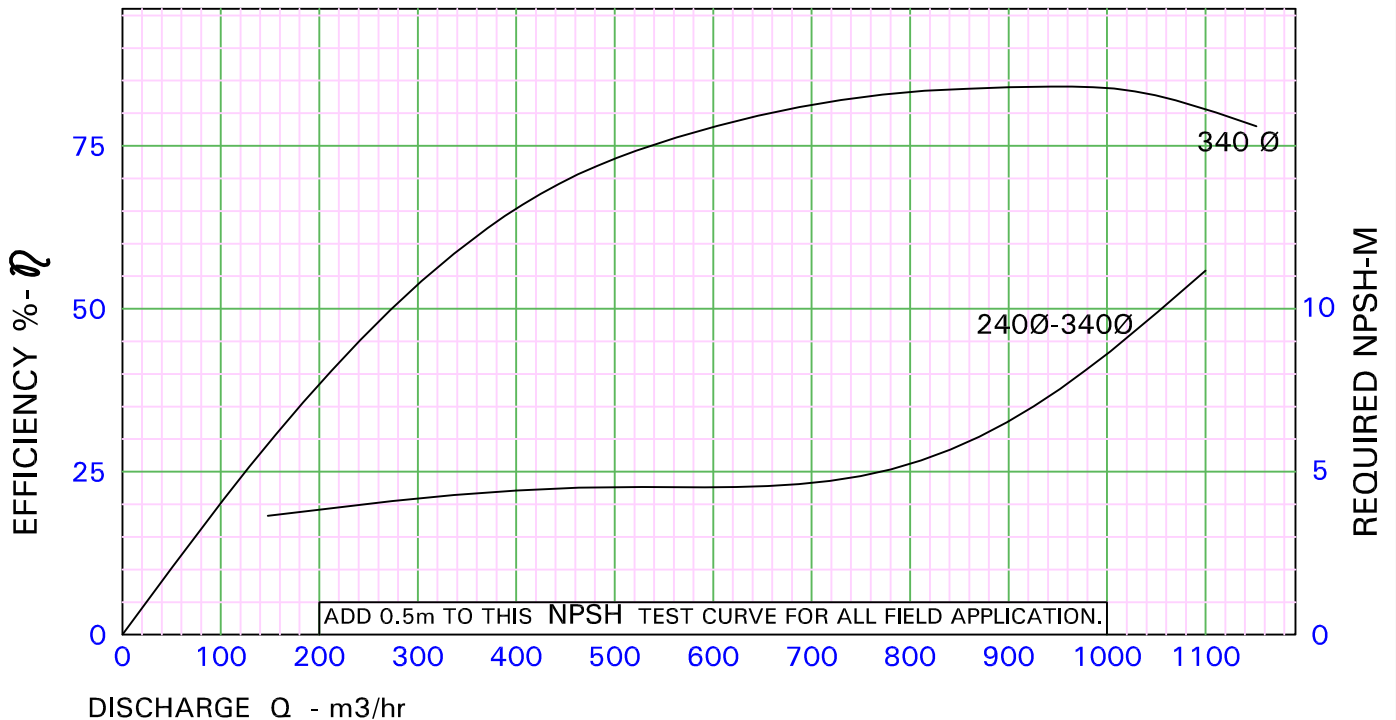
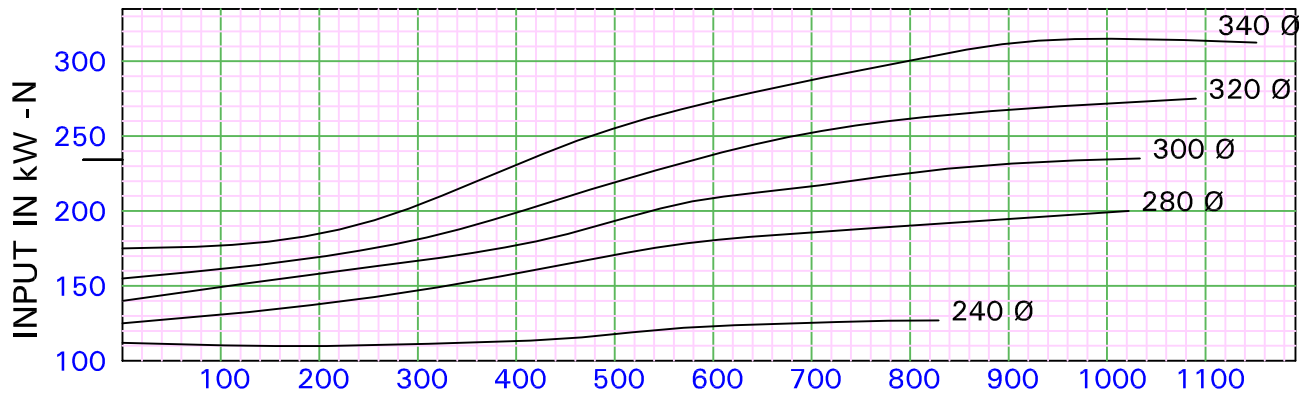
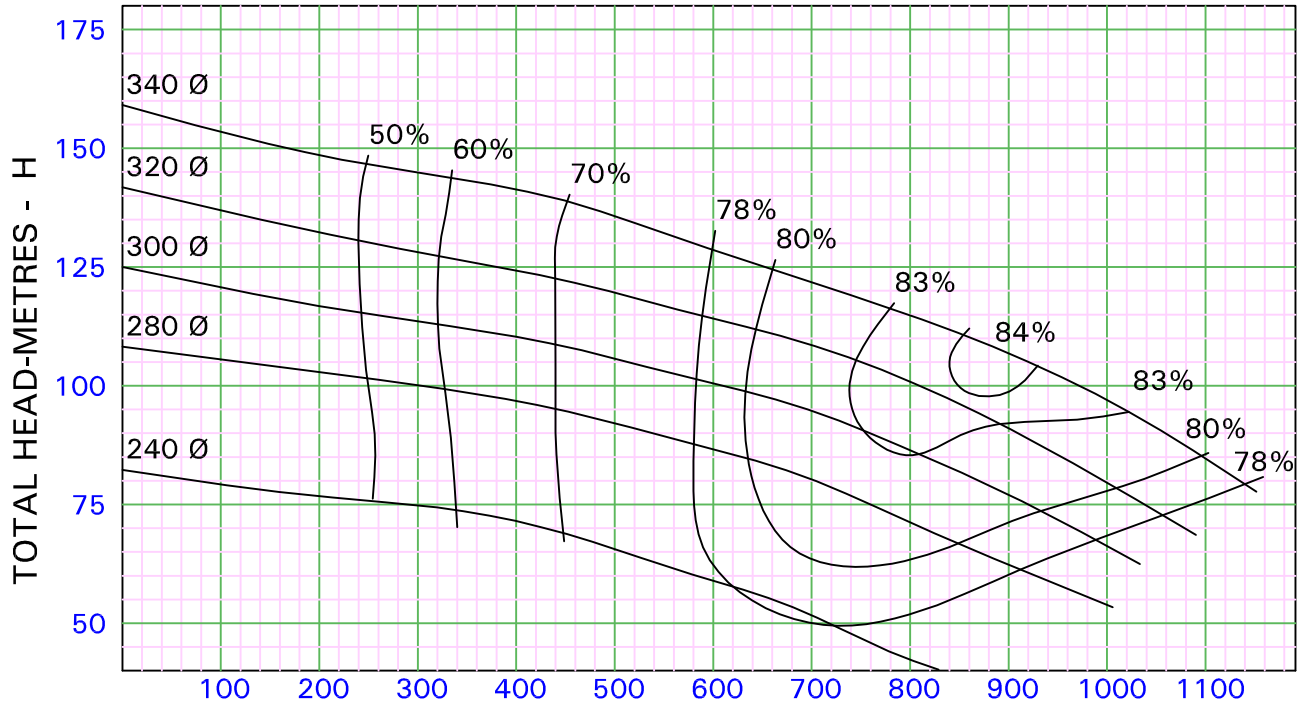

RECOMMENDED DELIVERY PIPE SIZE mm	200 Ø	250 Ø	300 Ø	350 Ø	400 Ø	
RECOMMENDED SUCTION PIPE SIZE mm	250 Ø	300 Ø	350 Ø	400 Ø	450 Ø	500 Ø

KIRLOSKAR BROTHERS LIMITED

NO. HA17H29AA0 0

PERFORMANCE CURVE OF PUMP i-HT15XF(2ST)

SUC. 200 mm DEL 150mm

n = 2950 rpm
(NOMINAL)

THIS CURVE RELATES TO LIQUID OF SP.GR. = 1.0



Enriching Lives

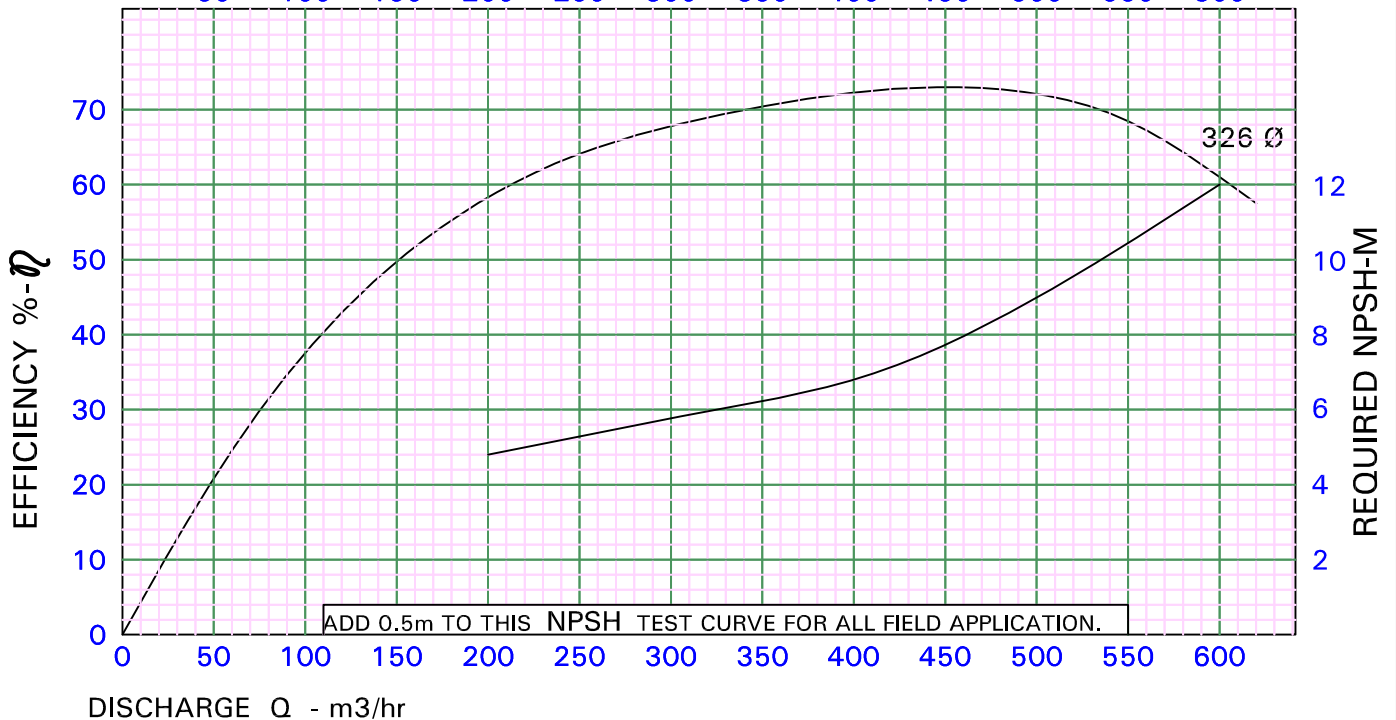
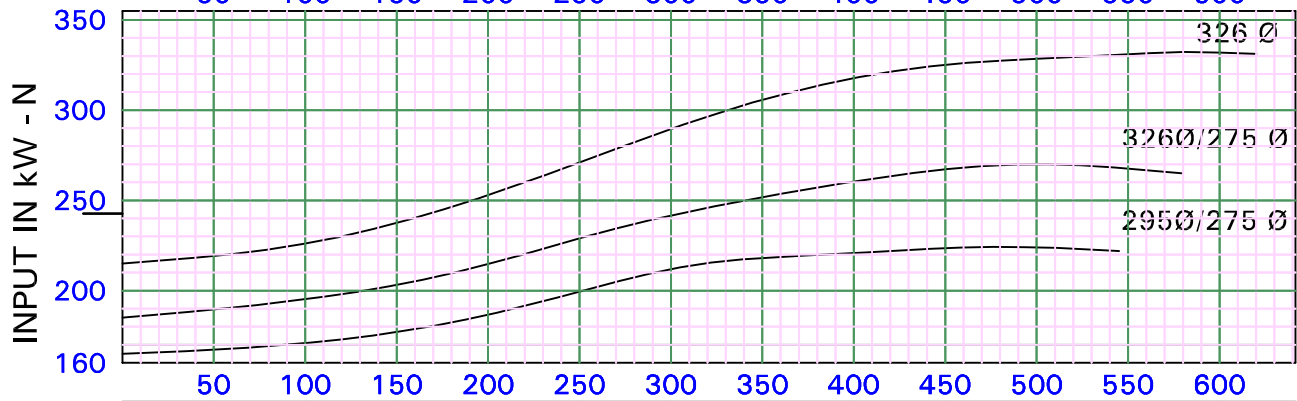
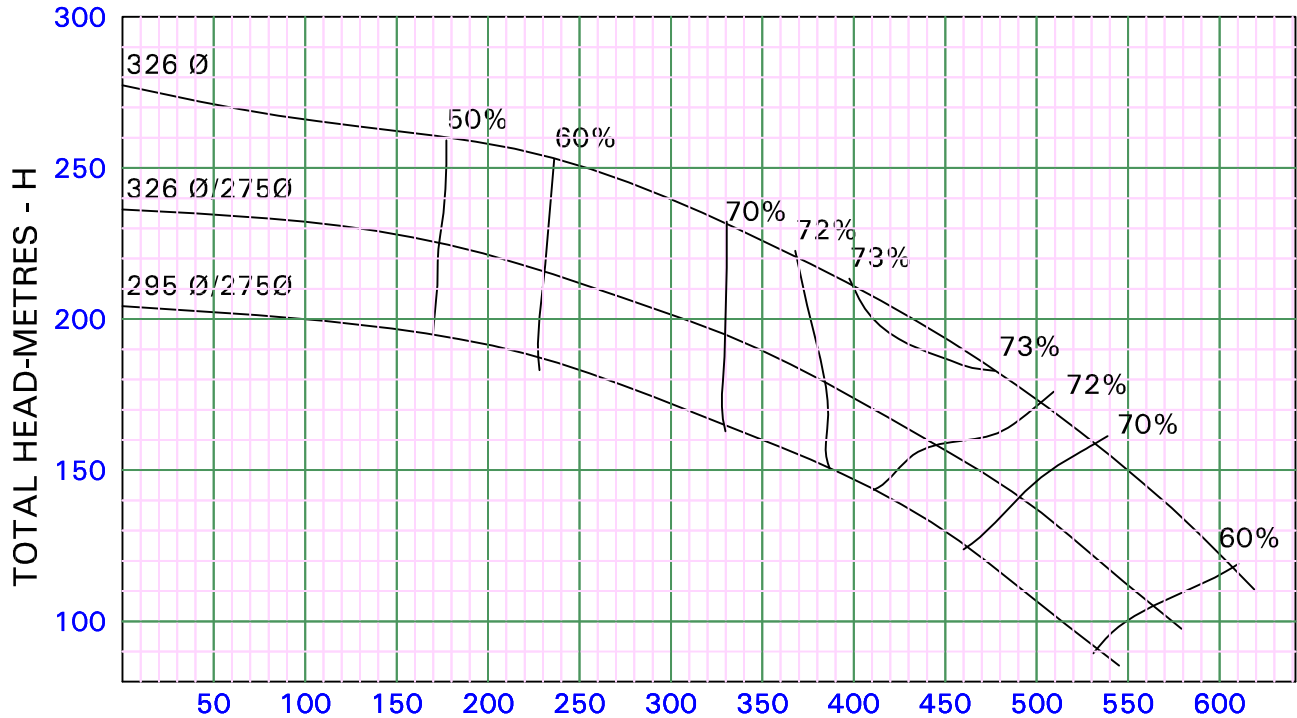

DISCHARGE Q - m3/hr

RECOMMENDED DELIVERY PIPE SIZE mm	150	200	250	300
RECOMMENDED SUCTION PIPE SIZE mm	200	250	300	350

KIRLOSKAR BROTHERS LIMITED

NO. HA17H28AAO-0

PERFORMANCE CURVE OF PUMP i-HT15XE(2ST)

SUC. 200 mm DEL 150 mm

THIS CURVE RELATES TO LIQUID OF SP.GR. = 1.0

n = 2950 rpm
(NOMINAL)



Enriching Lives

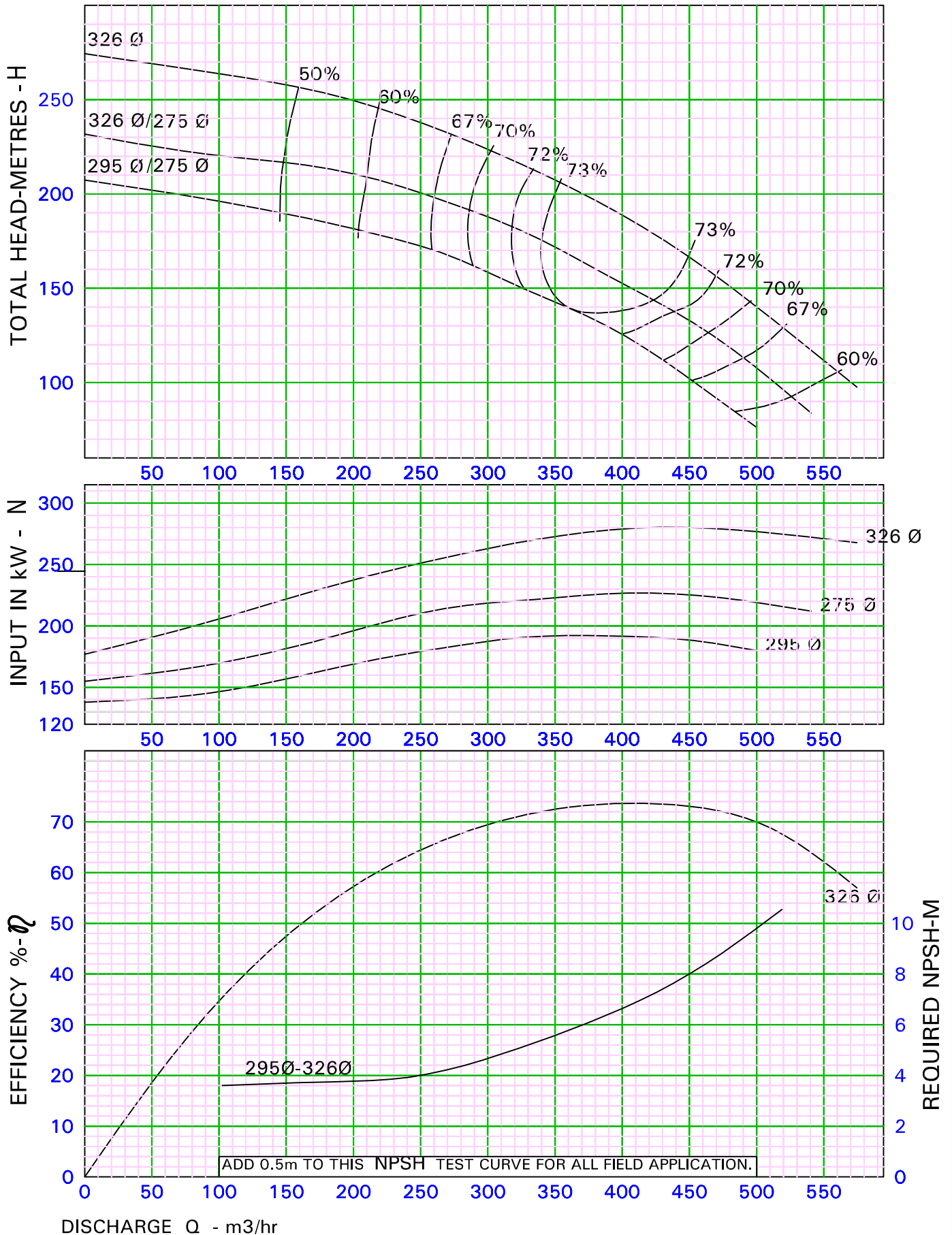

DISCHARGE Q - m³/hr

RECOMMENDED DELIVERY PIPE SIZE mm	150	200	250	
RECOMMENDED SUCTION PIPE SIZE mm	200	250	300	350

KIRLOSKAR BROTHERS LIMITED

NO. HA17H23AA0-0

PERFORMANCE CURVE OF PUMP i-HT15DF

SUC.200 mm DEL 150mm

THIS CURVE RELATES TO LIQUID OF SP.GR. = 1.0

n = 2950 rpm
(NOMINAL)



Enriching Lives

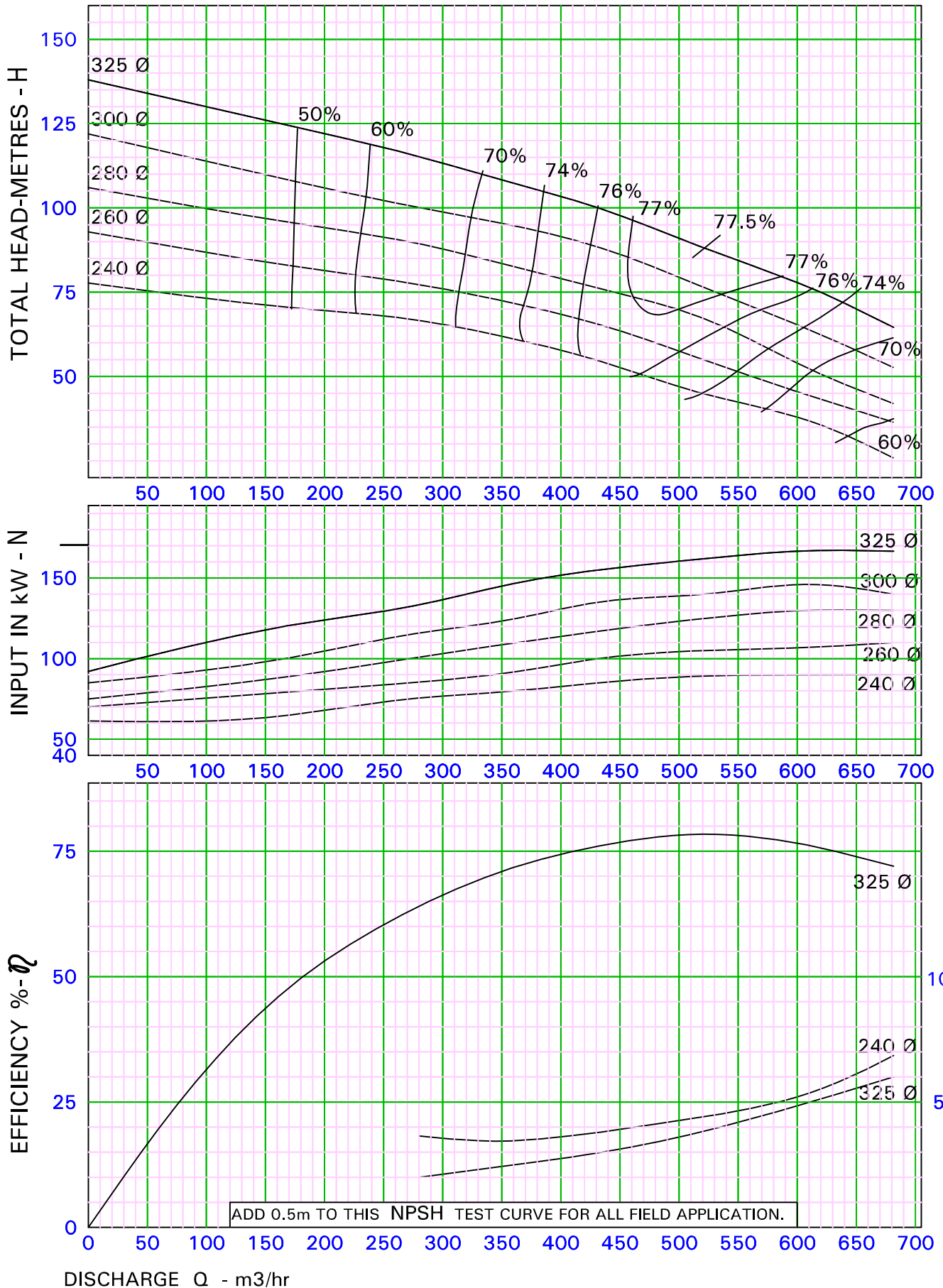

RECOMMENDED DELIVERY PIPE SIZE mm	150Ø	200Ø	250Ø	300Ø	350Ø	400Ø
RECOMMENDED SUCTION PIPE SIZE mm	200Ø	250Ø	300Ø	350Ø	400Ø	

KIRLOSKAR BROTHERS LIMITED

No. HA17H22AAO 0



Enriching Lives

PERFORMANCE CURVE OF PUMP i-HT15DA

SUC. 200 mm DEL 150 mm

n = 2900 rpm
(NOMINAL)

THIS CURVE RELATES TO LIQUID OF SP.GR. = 1.0

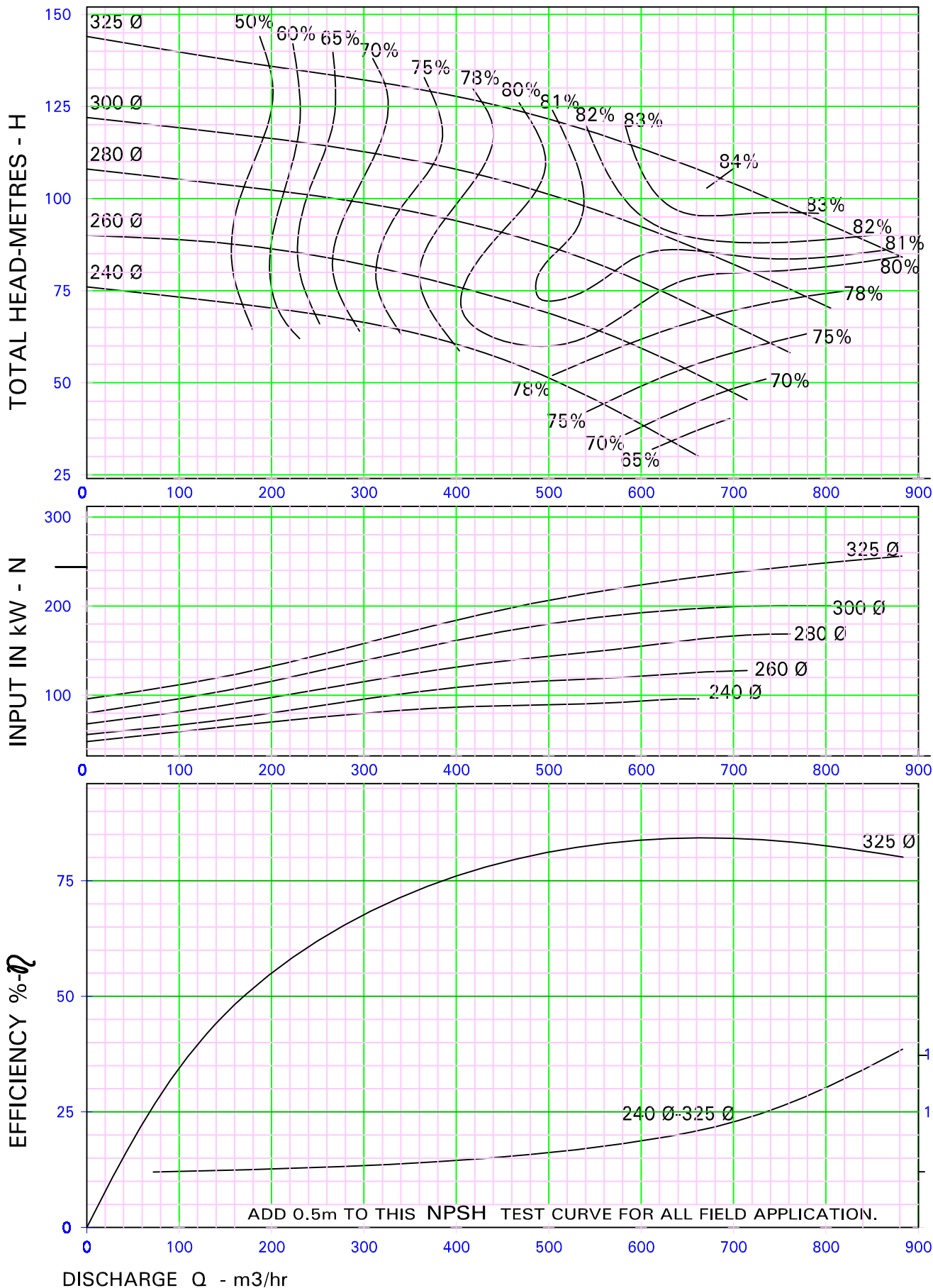

RECOMMENDED DELIVERY PIPE SIZE mm	200 Ø	250 Ø	300 Ø	350 Ø
RECOMMENDED SUCTION PIPE SIZE mm	250 Ø	300 Ø	350 Ø	400 Ø

KIRLOSKAR BROTHERS LIMITED

NO. HA17H21AA0-0

PERFORMANCE CURVE OF PUMP i-HT15BE

SUC. 200mm DEL 150mm

THIS CURVE RELATES TO LIQUID OF SP.GR. = 1.0

n = 2950 rpm
(NOMINAL)



Enriching Lives

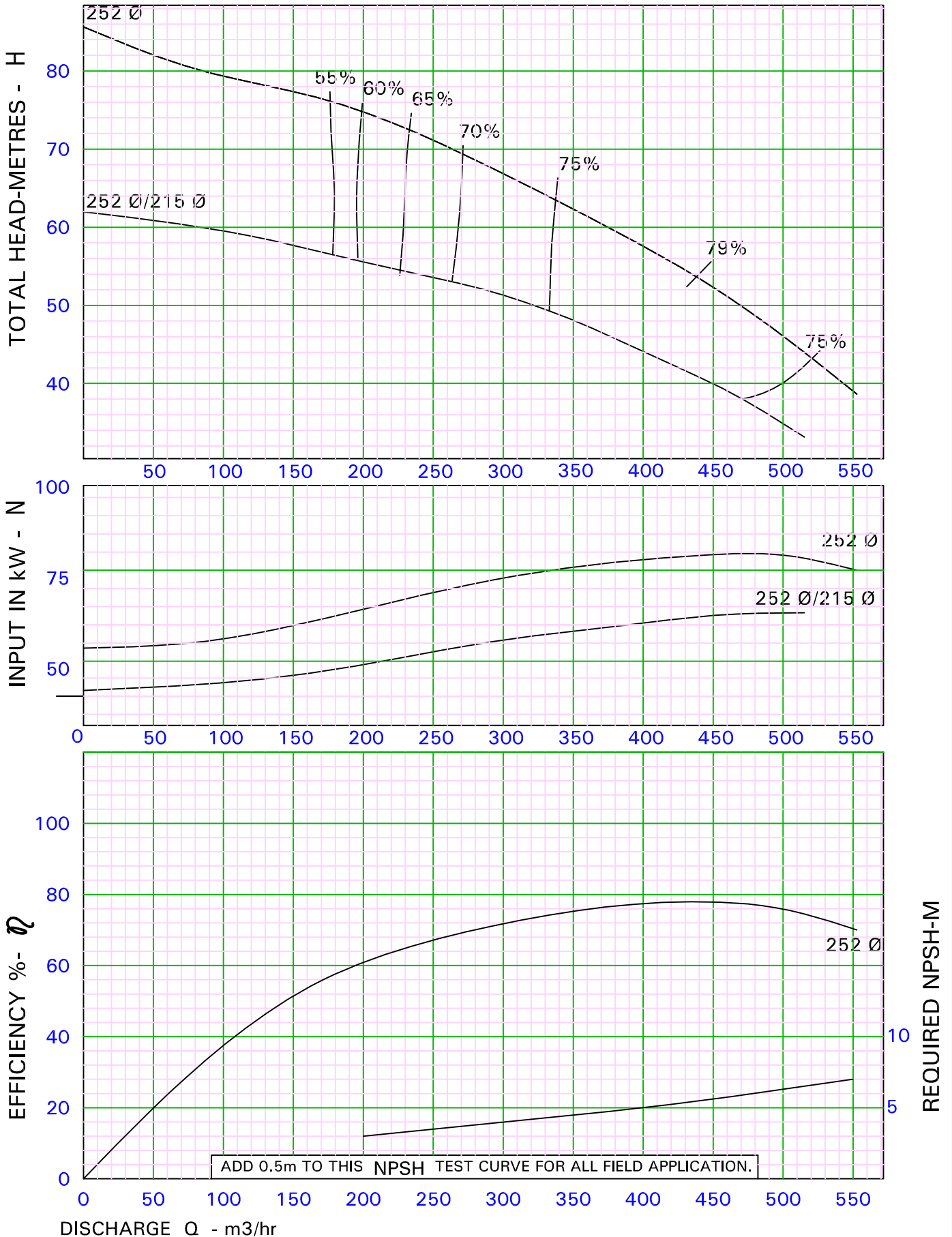

RECOMMENDED DELIVERY PIPE SIZE mm	150Ø	200Ø	250Ø	
RECOMMENDED SUCTION PIPE SIZE mm	200Ø	250Ø	300Ø	350Ø

KIRLOSKAR BROTHERS LIMITED

NO. HA17H20AAO 0



PERFORMANCE CURVE OF PUMP i-HT15BA

SUC. 200 mm DEL 150mm

THIS CURVE RELATES TO LIQUID OF SP.GR. = 1.0

n = 2900 rpm
(NOMINAL)

Enriching Lives

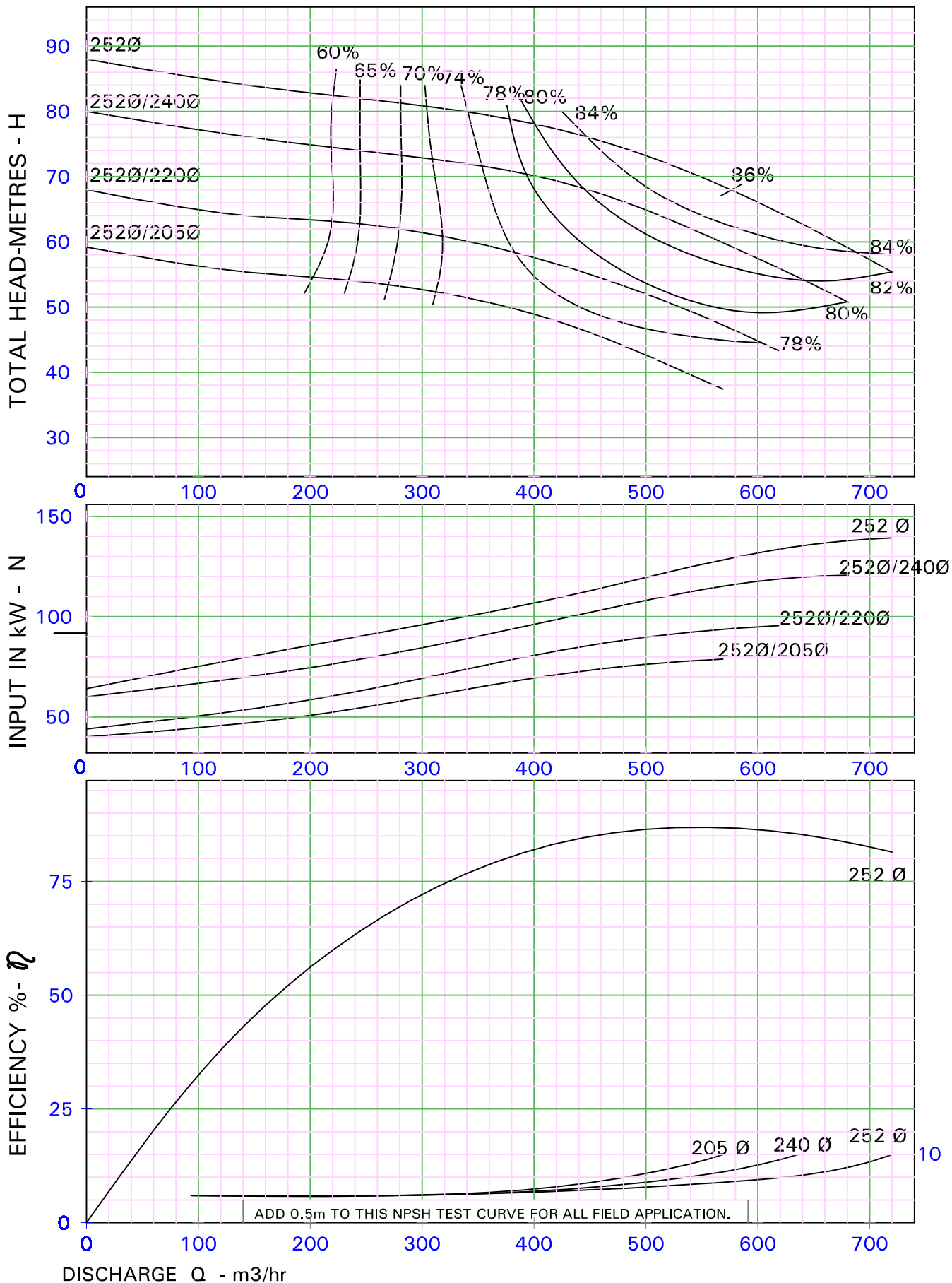

RECOMMENDED DELIVERY PIPE SIZE mm	150 Ø	200 Ø	250 Ø	300 Ø	
RECOMMENDED SUCTION PIPE SIZE mm	200 Ø	250 Ø	300 Ø	350 Ø	400 Ø

KIRLOSKAR BROTHERS LIMITED

NO. HA17H27AA0 0

PERFORMANCE CURVE OF PUMP i-HT12XD(2ST)

SUC. 150 mm DEL 125 mm

THIS CURVE RELATES TO LIQUID OF SP.GR. = 1.0

n = 2950 rpm
(NOMINAL)



Enriching Lives

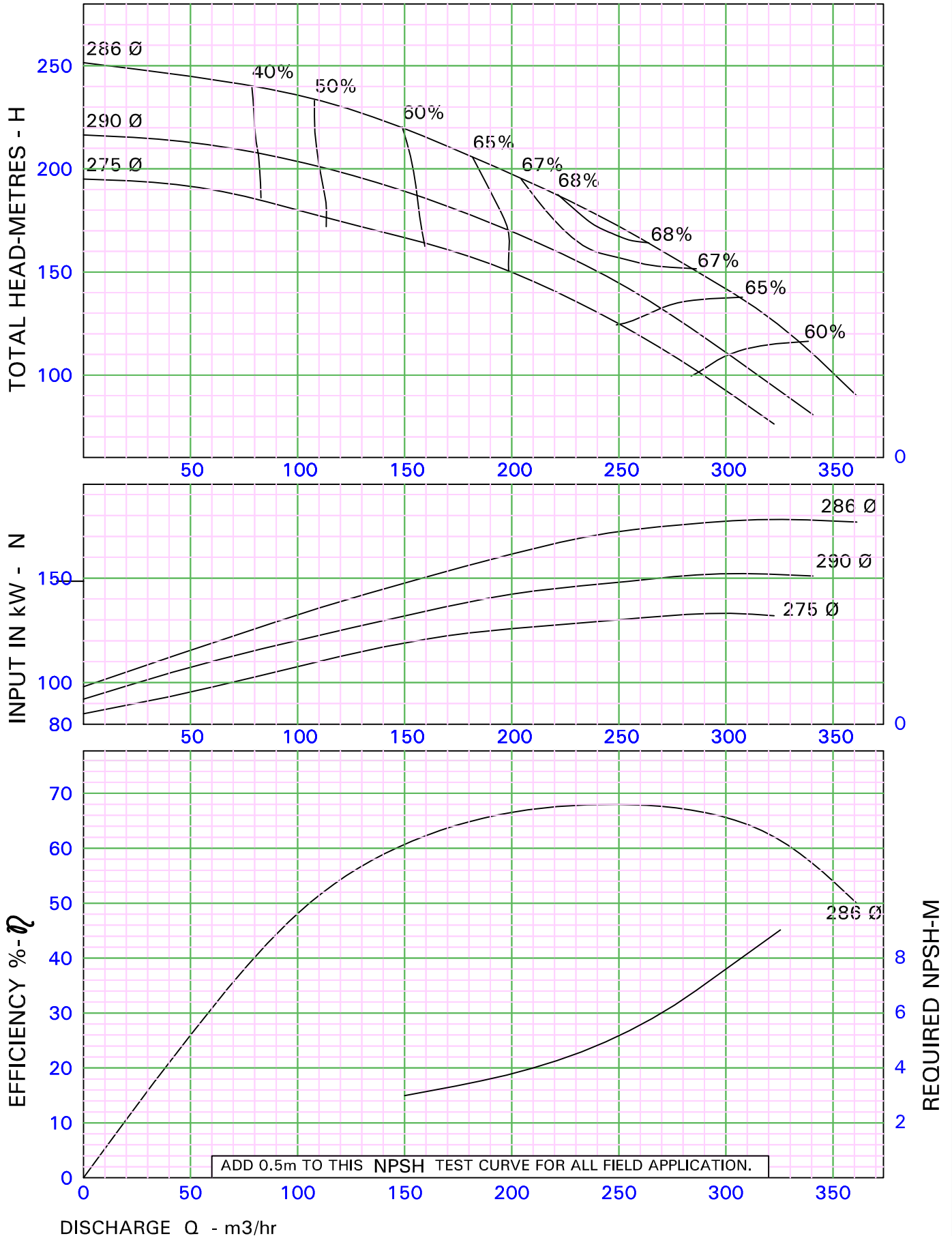

RECOMMENDED DELIVERY PIPE SIZE mm	125 Ø	150 Ø	200 Ø	250 Ø
RECOMMENDED SUCTION PIPE SIZE mm	150 Ø	175 Ø	200 Ø	250 Ø

KIRLOSKAR BROTHERS LIMITED

NO. HA17H19AA0-0

PERFORMANCE CURVE OF PUMP i-HT12EA

SUC.150 mm DEL 125 mm

THIS CURVE RELATES TO LIQUID OF SP.GR. = 1.0

n = 2900 rpm
(NOMINAL)



Enriching Lives

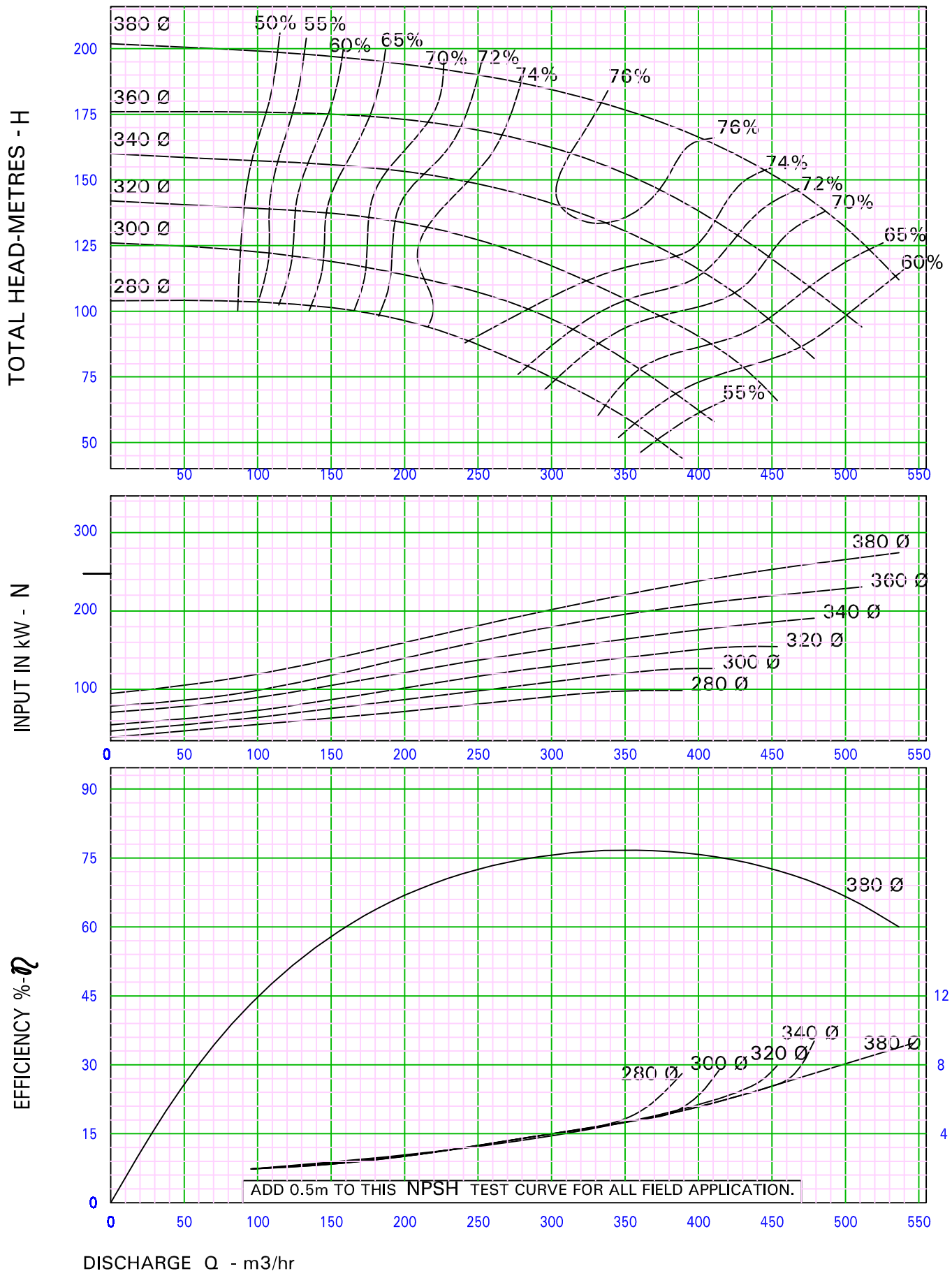

DISCHARGE Q - m³/hr

RECOMMENDED DELIVERY PIPE SIZE mm	150Ø	200Ø	250Ø	300Ø
RECOMMENDED SUCTION PIPE SIZE mm	200Ø	300Ø		

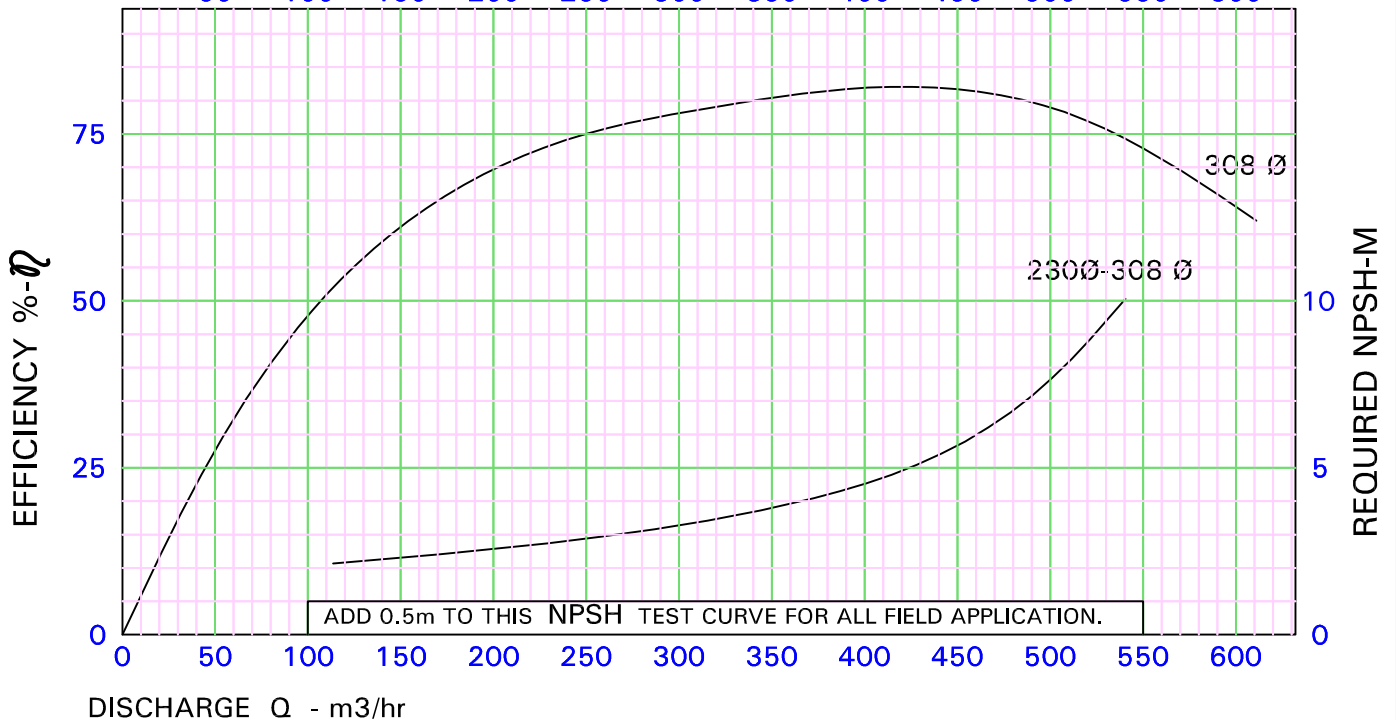
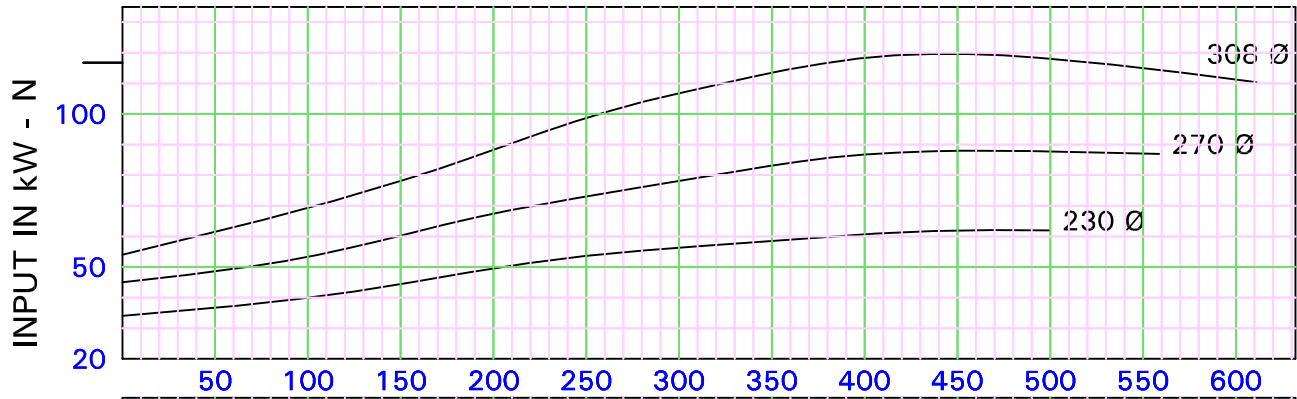
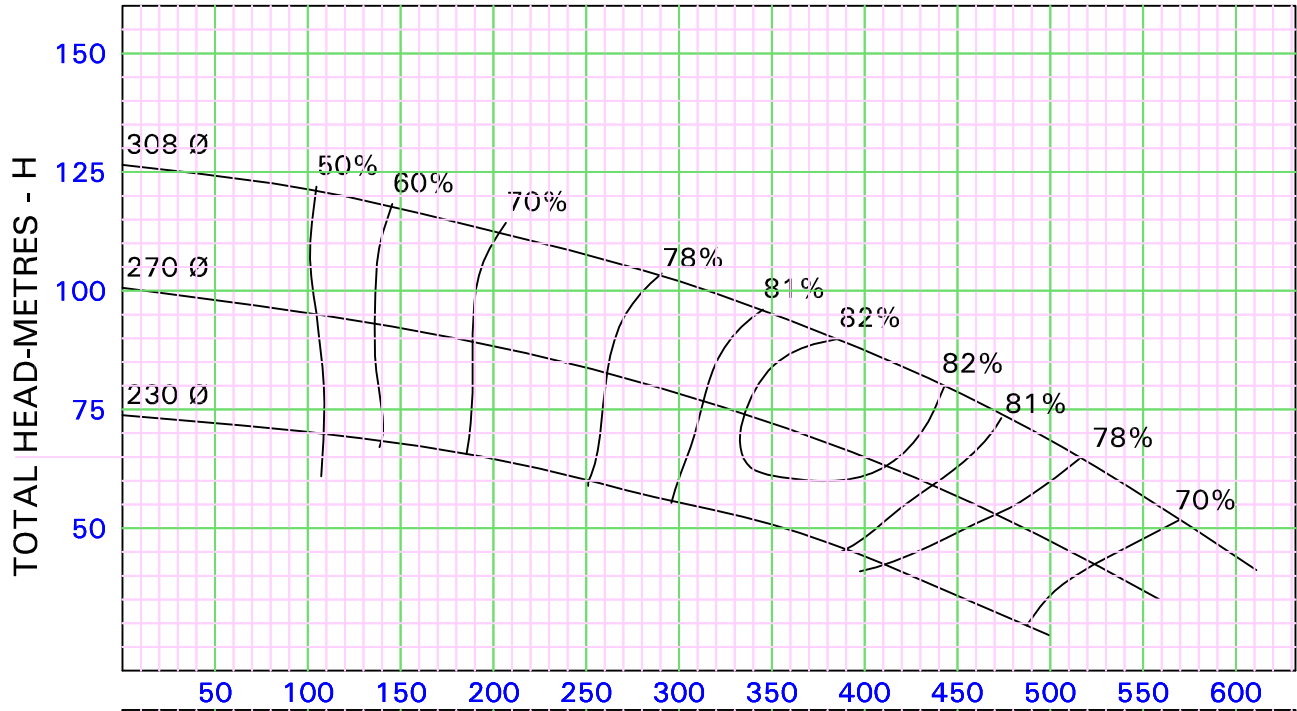

RECOMMENDED DELIVERY PIPE SIZE mm	150 Ø	200 Ø	250 Ø	300 Ø
RECOMMENDED SUCTION PIPE SIZE mm	200 Ø	250 Ø	300 Ø	350 Ø

KIRLOSKAR BROTHERS LIMITED

NO. HA17H17AAO 0

PERFORMANCE CURVE OF PUMP i-HT12DA

SUC.150 mm DEL125 mm

n = 2900 rpm
(NOMINAL)



Enriching Lives

THIS CURVE RELATES TO LIQUID OF SP.GR. = 1.0

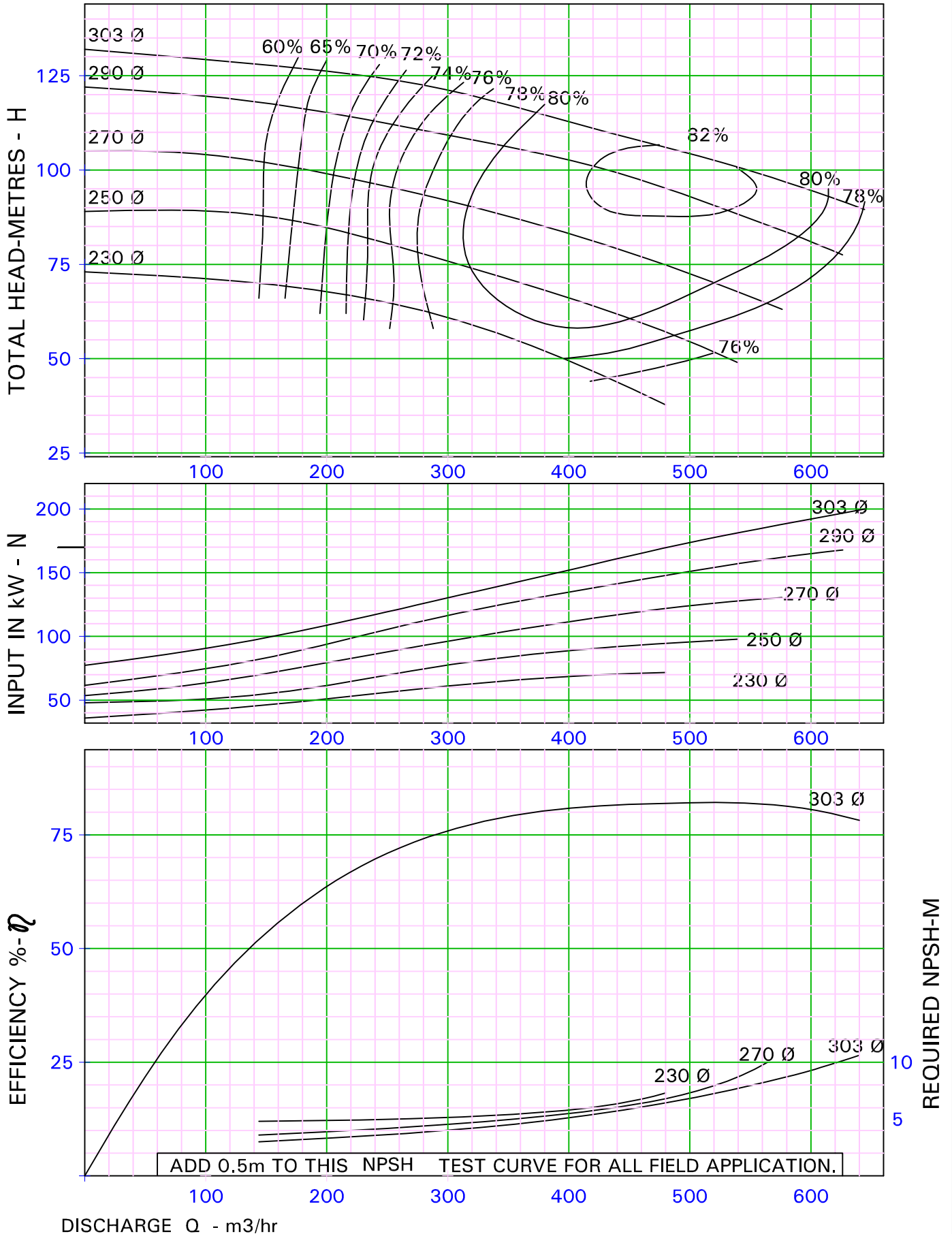

ADD 0.5m TO THIS NPSH TEST CURVE FOR ALL FIELD APPLICATION.

RECOMMENDED DELIVERY PIPE SIZE mm	150 Ø	200 Ø	250 Ø	300 Ø
RECOMMENDED SUCTION PIPE SIZE mm	200 Ø	250 Ø	300 Ø	350 Ø

KIRLOSKAR BROTHERS LIMITED

NO. HA17H16AA0 0

PERFORMANCE CURVE OF PUMP i-HT12CG

SUC. 150 mm DEL 125 mm

THIS CURVE RELATES TO LIQUID OF SP.GR. = 1.0

n = 2950 rpm
(NOMINAL)



Enriching Lives

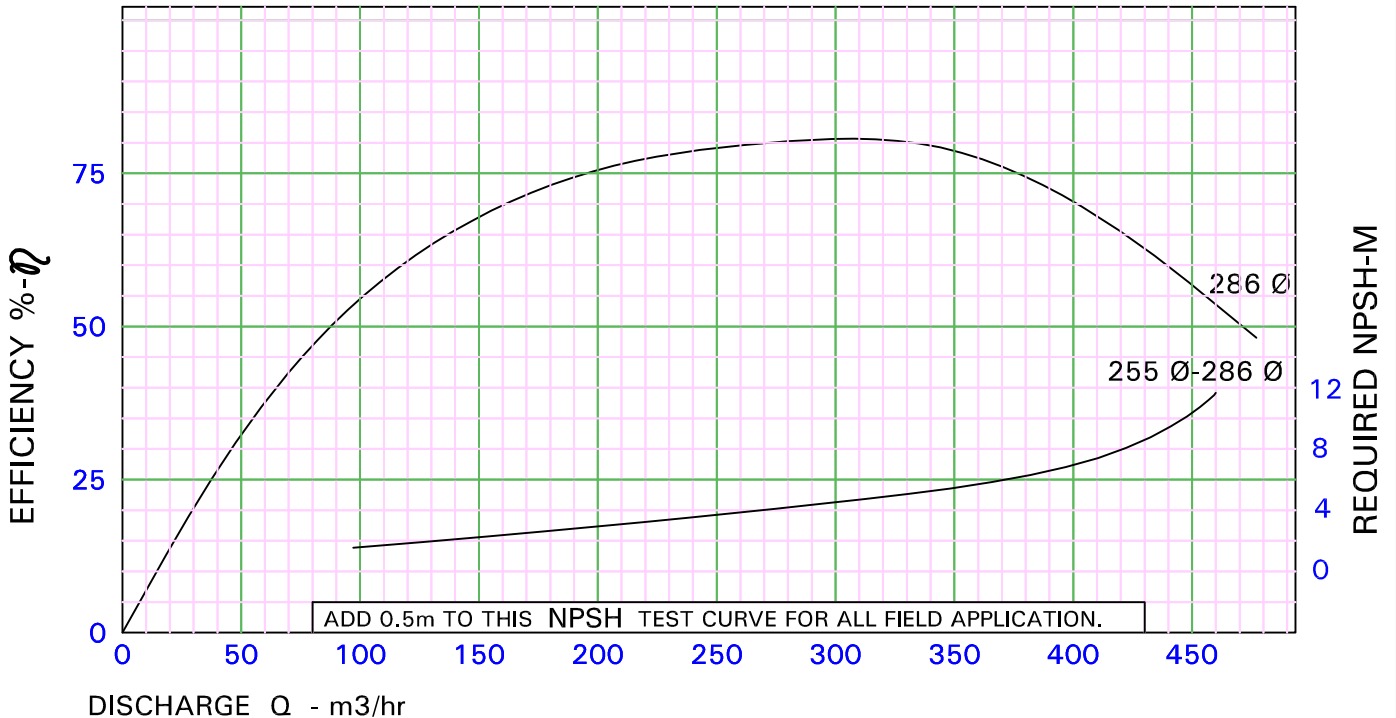
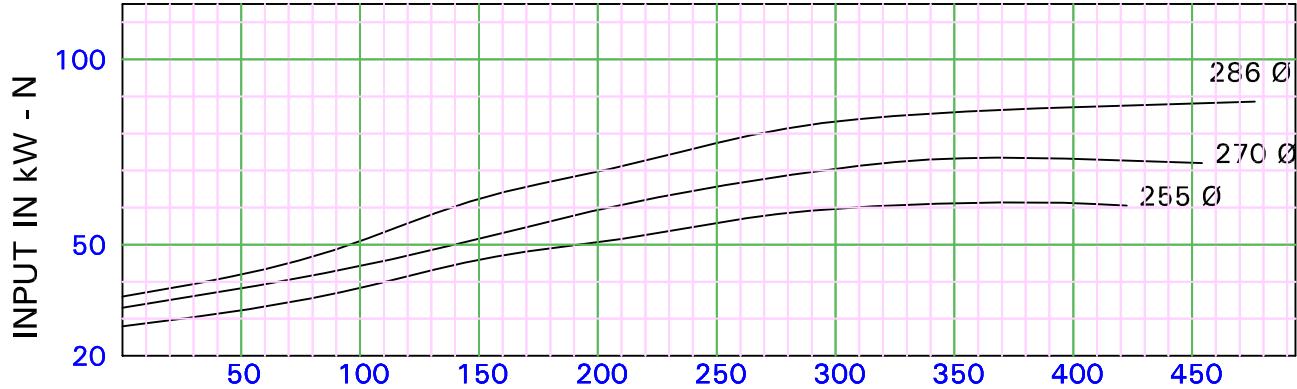
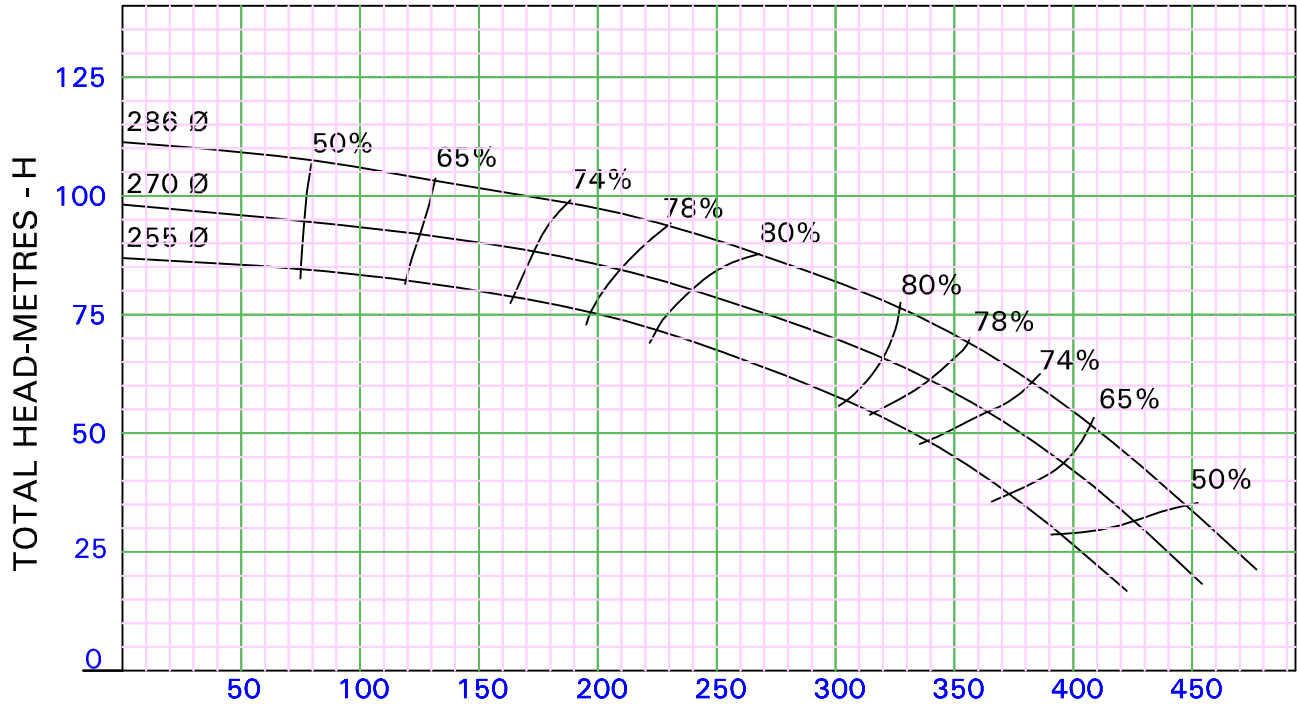

RECOMMENDED DELIVERY PIPE SIZE mm	125Ø	150Ø	200Ø	250Ø	
RECOMMENDED SUCTION PIPE SIZE mm	175Ø	200Ø	250Ø	300Ø	350Ø

KIRLOSKAR BROTHERS LIMITED

NO. HA17H15AA0-0

PERFORMANCE CURVE OF PUMP HT12CF

SUC. 150 mm DEL 125 mm

THIS CURVE RELATES TO LIQUID OF SP.GR. = 1.0

n = 2950^{rpm}
(NOMINAL)



Enriching Lives

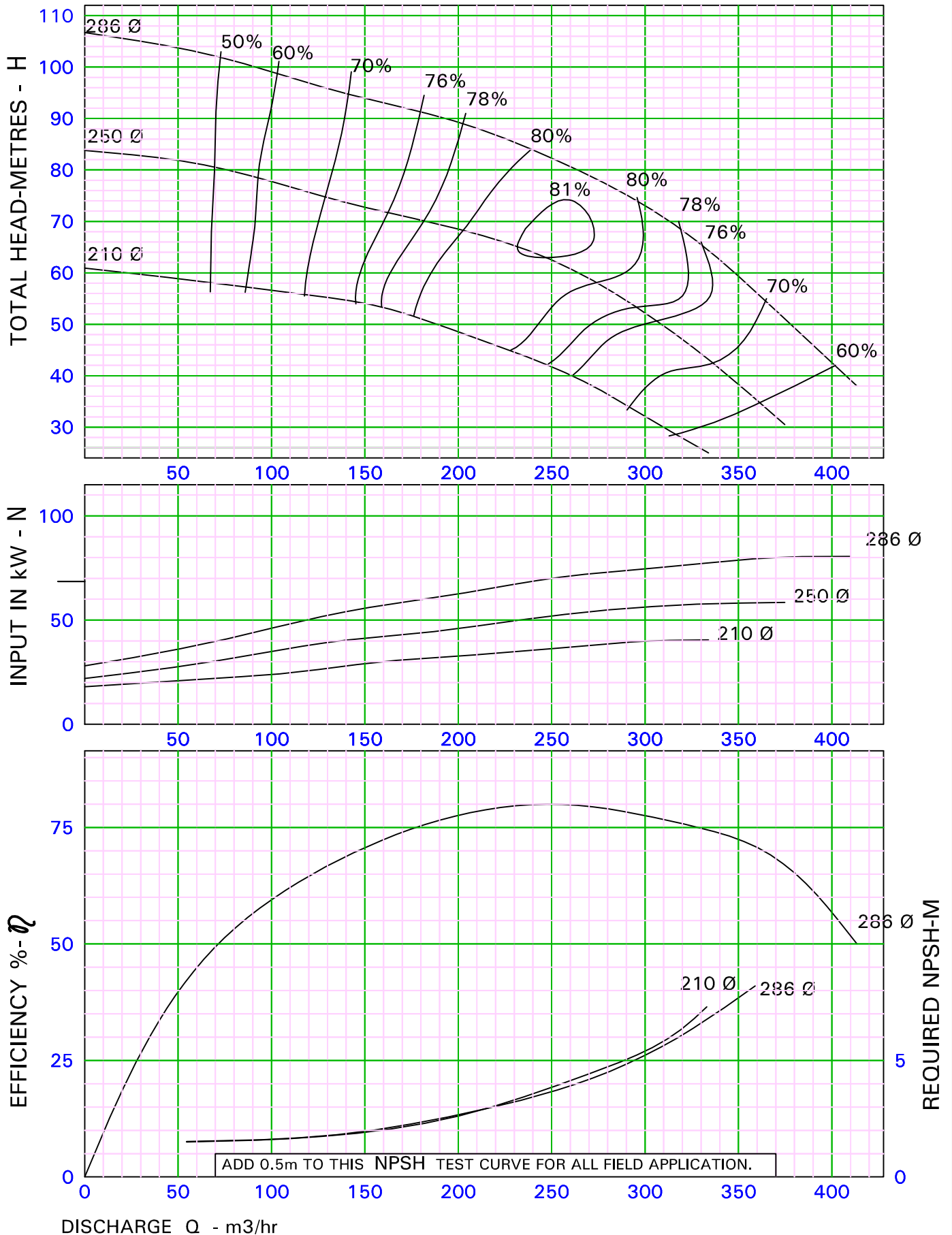

RECOMMENDED DELIVERY PIPE SIZE mm	150Ø	200Ø	250Ø
RECOMMENDED SUCTION PIPE SIZE mm	200Ø	250Ø	300Ø

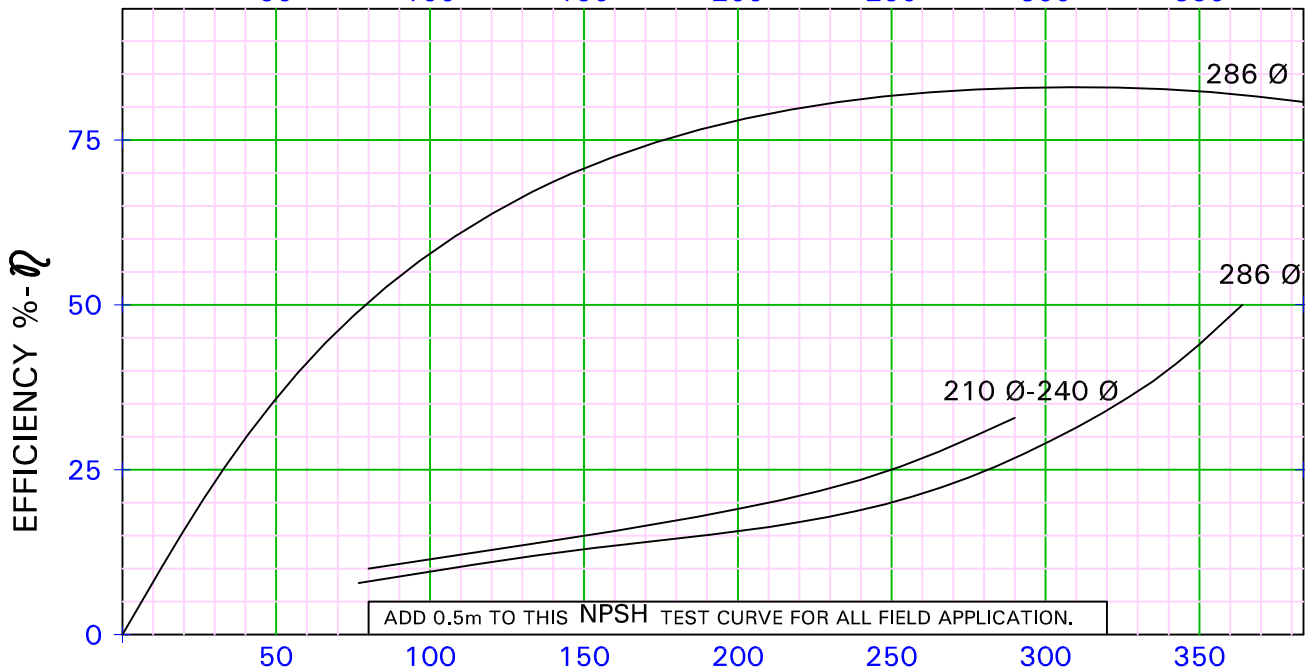
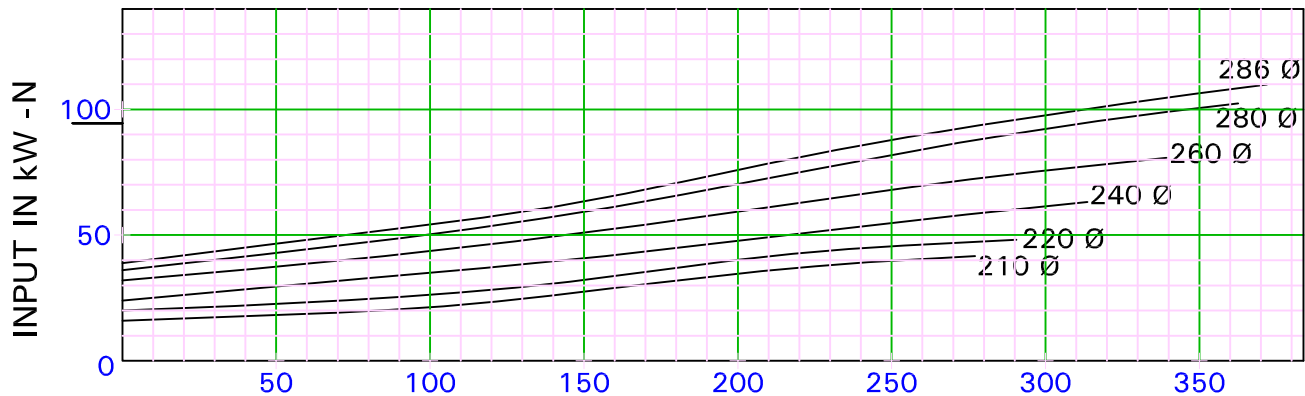
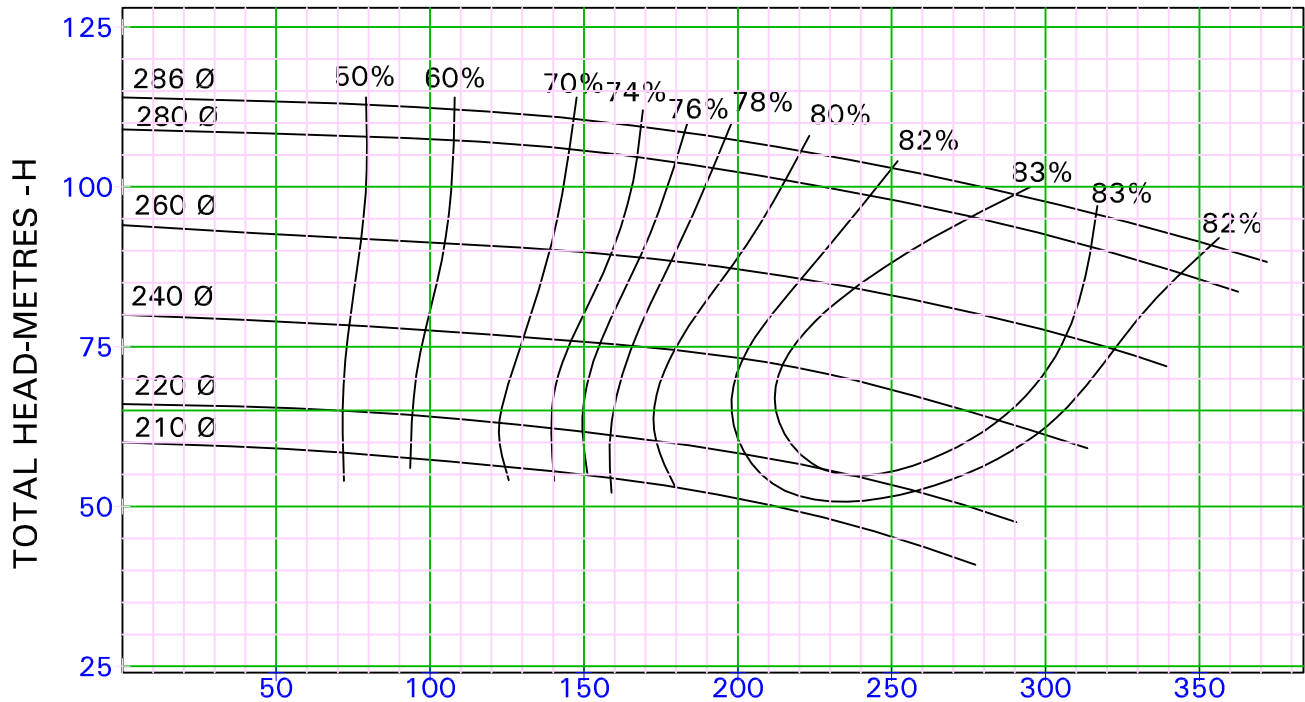

REQUIRED NPSH-M

DISCHARGE Q - m3/hr

RECOMMENDED DELIVERY PIPE SIZE mm	125 Ø	150 Ø	175 Ø	200 Ø	
RECOMMENDED SUCTION PIPE SIZE mm	150 Ø	175 Ø	200 Ø	250 Ø	

KIRLOSKAR BROTHERS LIMITED

NO. HA17H13AA0-0

PERFORMANCE CURVE OF PUMP /HT12BF

SUC. 150 mm DEL 125 mm

THIS CURVE RELATES TO LIQUID OF SP.GR. = 1.0

n = 2950 rpm
(NOMINAL)



Enriching Lives

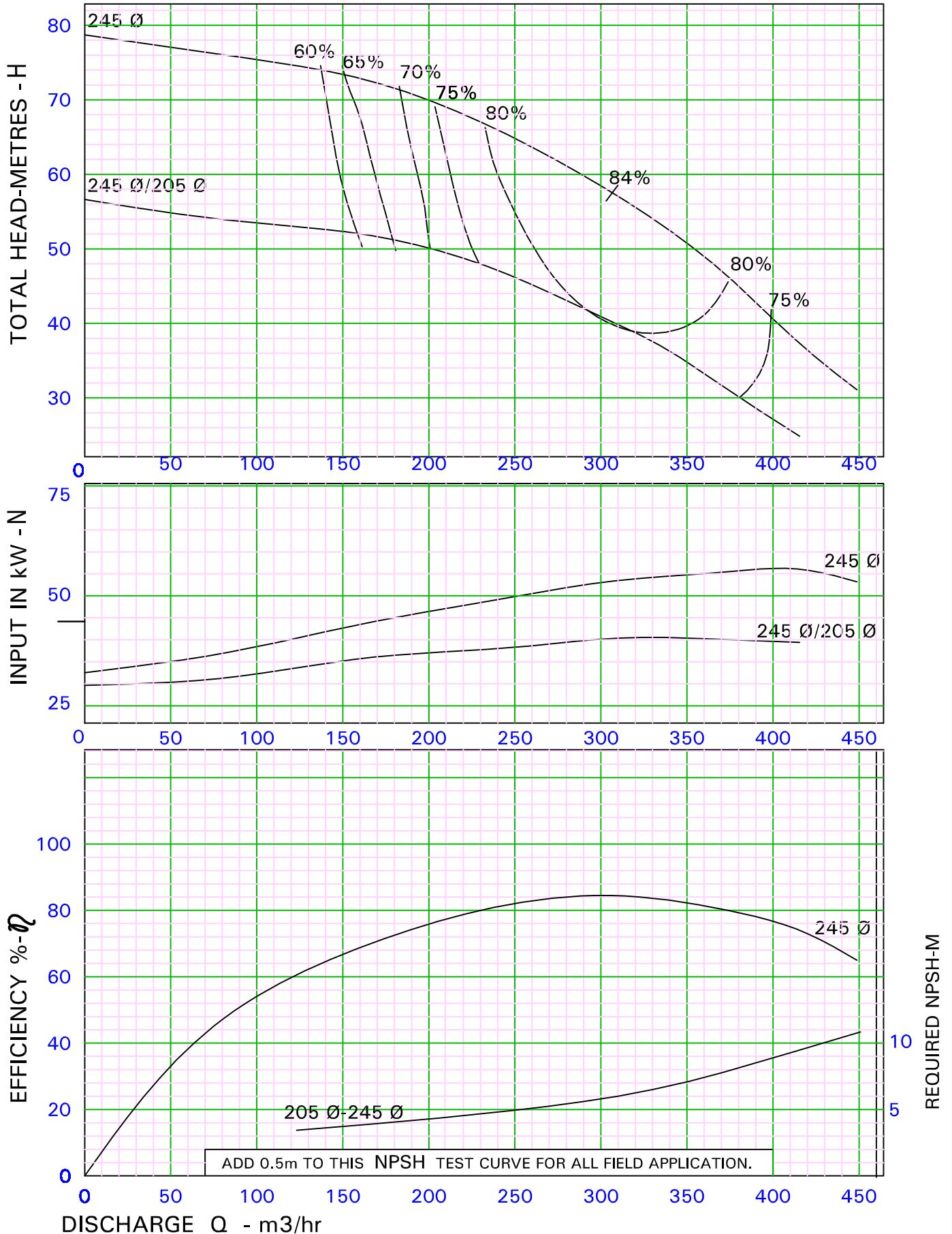

RECOMMENDED DELIVERY PIPE SIZE mm	150Ø	200Ø	250Ø
RECOMMENDED SUCTION PIPE SIZE mm	200Ø	250Ø	300Ø

KIRLOSKAR BROTHERS LIMITED

NO. HA17H12AAO 0

PERFORMANCE CURVE OF PUMP i-HT12BE

SUC. 150mm DEL 125 mm

THIS CURVE RELATES TO LIQUID OF SP.GR. = 1.0

n = 2950 rpm
(NOMINAL)



Enriching Lives

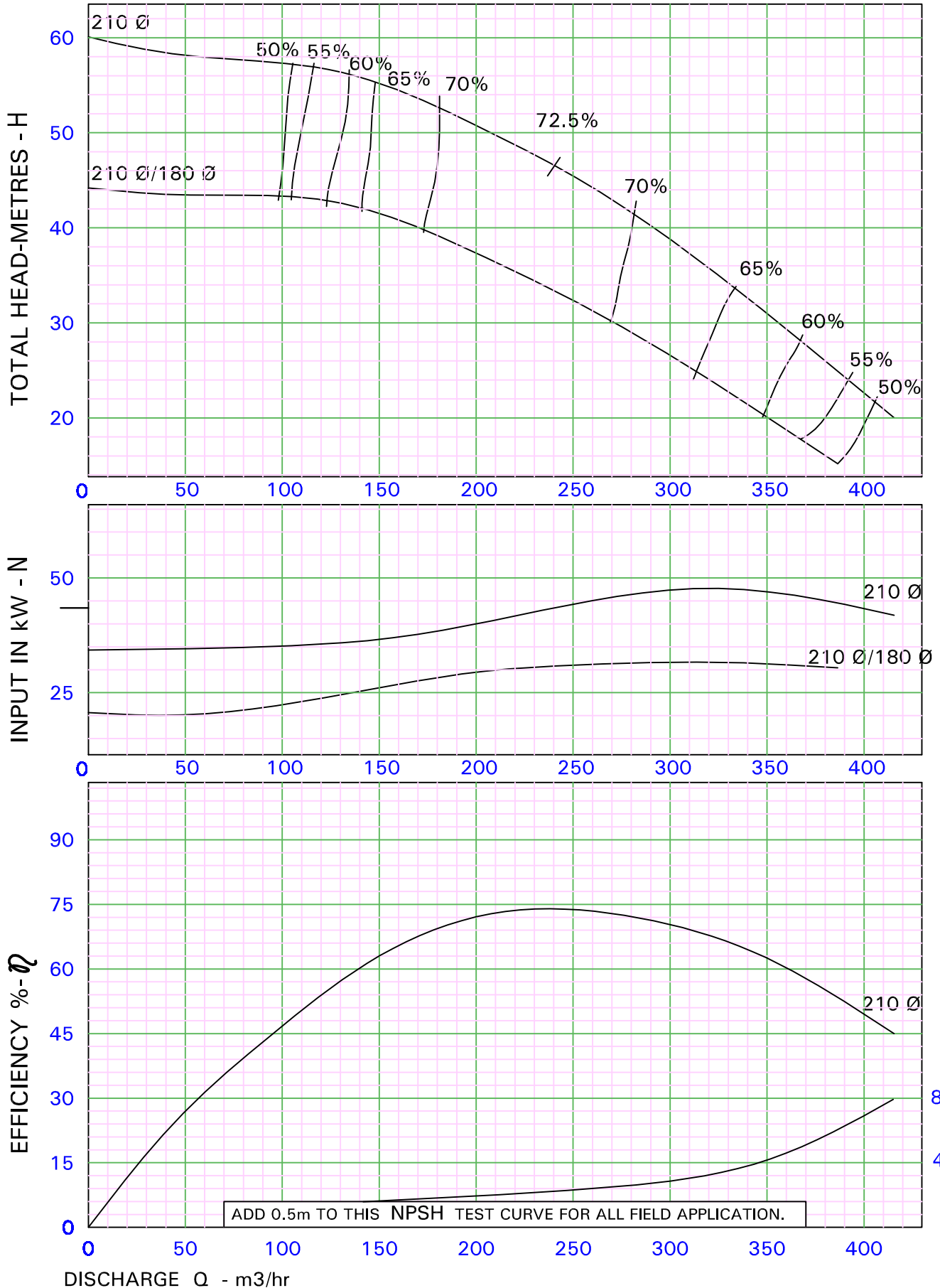

RECOMMENDED DELIVERY PIPE SIZE mm	125 Ø	150 Ø	175 Ø	200 Ø	250 Ø
RECOMMENDED SUCTION PIPE SIZE mm	125 Ø	200 Ø	250 Ø	300 Ø	

KIRLOSKAR BROTHERS LIMITED

NO. HA17H11AAO-0

PERFORMANCE CURVE OF PUMP i-HT12BD

SUC.150 mm DEL 125mm

THIS CURVE RELATES TO LIQUID OF SP.GR. = 1.0

n = 2950 rpm
(NOMINAL)



Enriching Lives

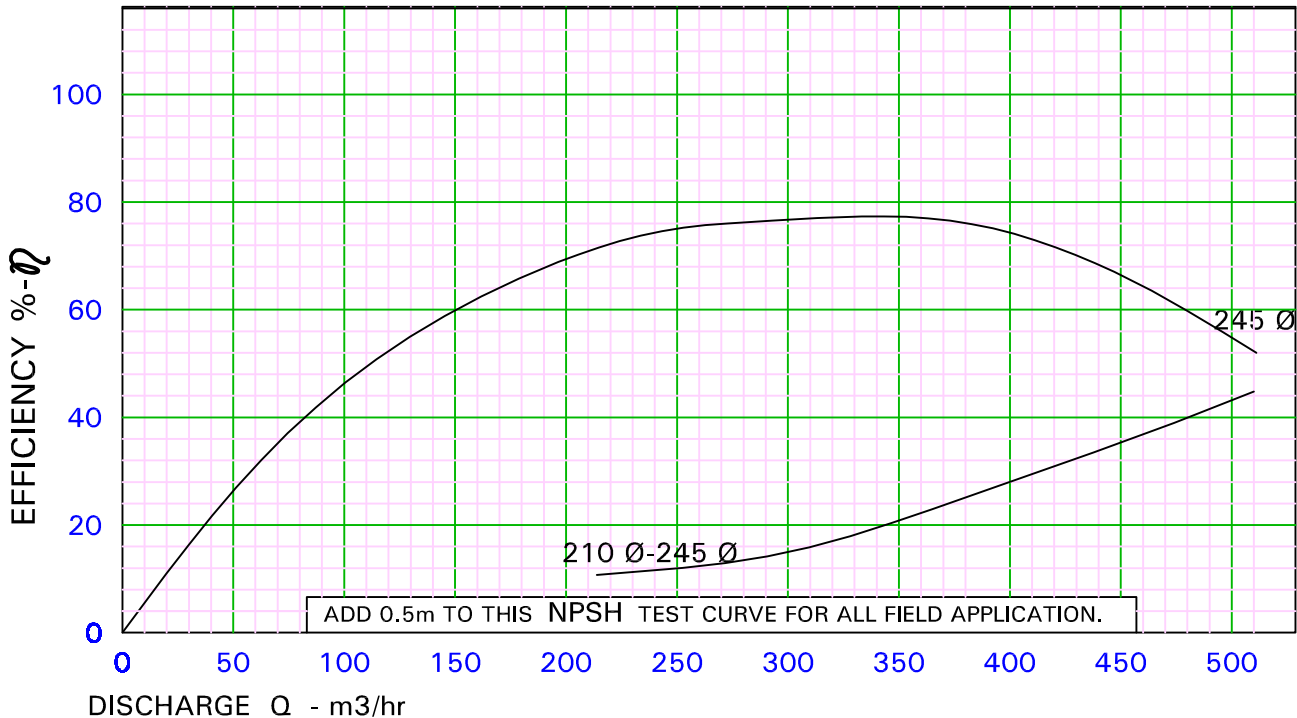
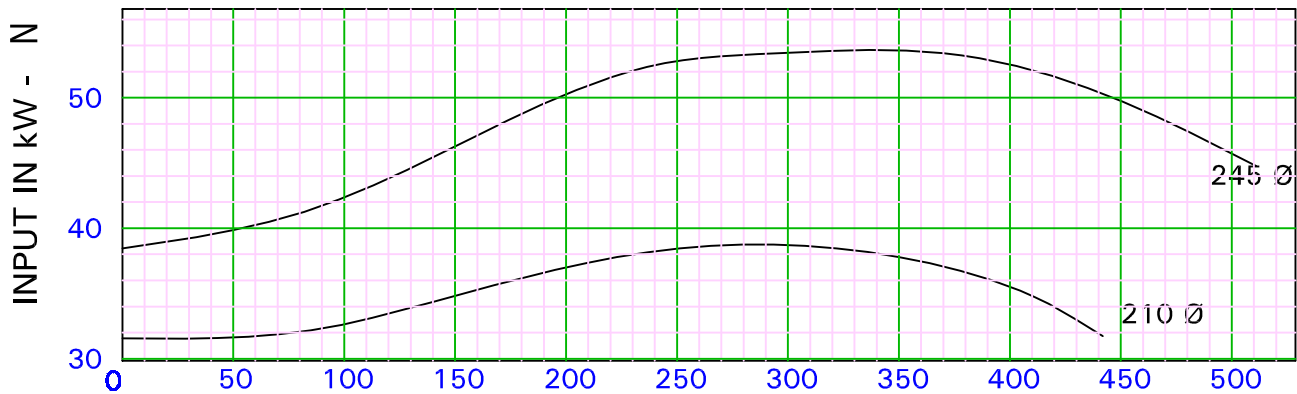
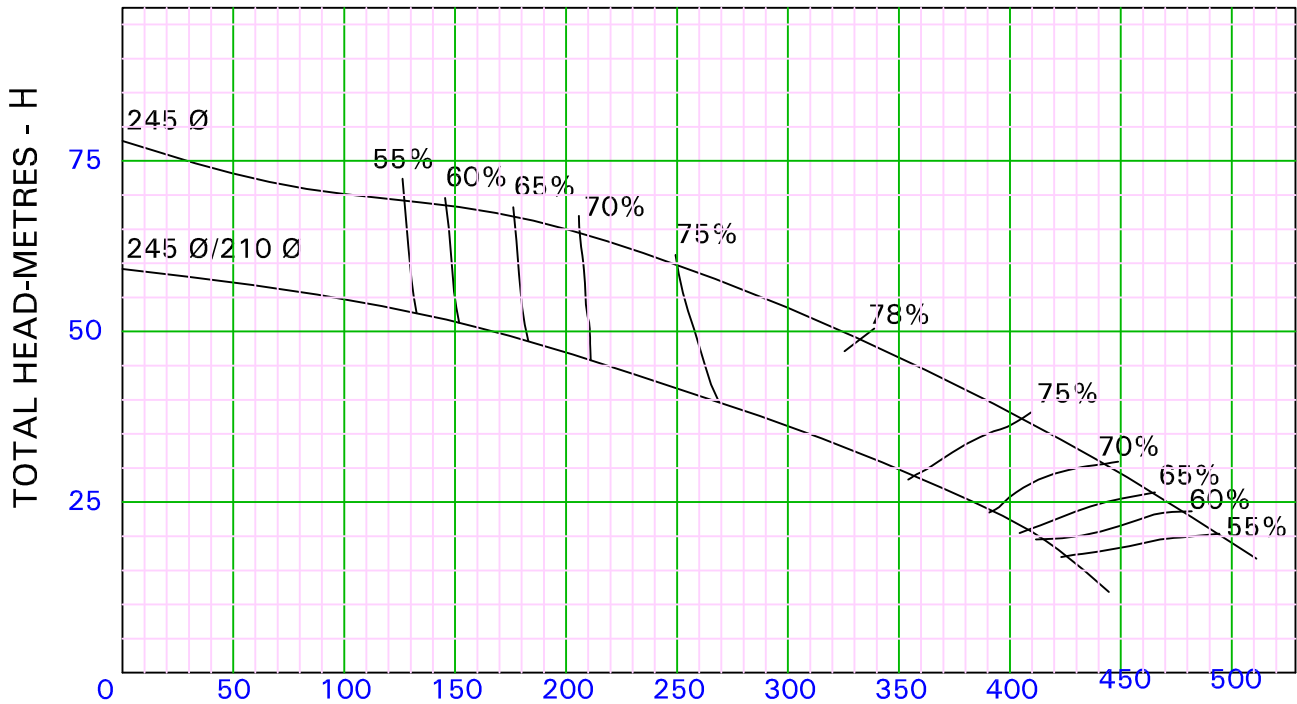

REQUIRED NPSH-M

RECOMMENDED DELIVERY PIPE SIZE mm	150Ø	200Ø	250Ø	
RECOMMENDED SUCTION PIPE SIZE mm	200Ø	250Ø	300Ø	350Ø

KIRLOSKAR BROTHERS LIMITED

NO. HA17H10AA0 0

PERFORMANCE CURVE OF PUMP i-HT12BA

SUC. 150mm DEL 125mm

THIS CURVE RELATES TO LIQUID OF SP.GR. = 1.0

n = 2900 rpm
(NOMINAL)



Enriching Lives

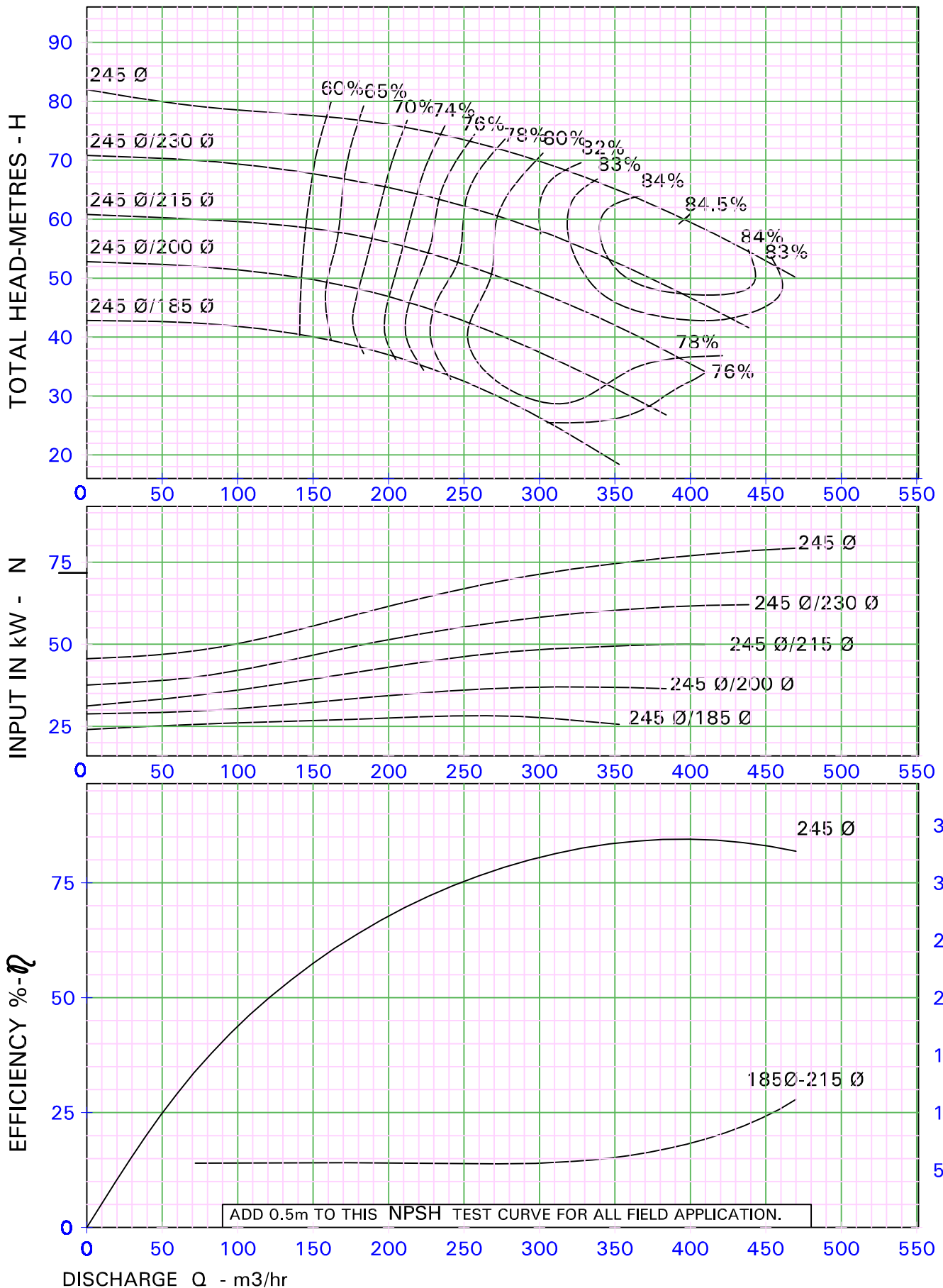

RECOMMENDED DELIVERY PIPE SIZE mm	150 \emptyset	200 \emptyset	250 \emptyset	300 \emptyset	350 \emptyset
RECOMMENDED SUCTION PIPE SIZE mm	200 \emptyset	250 \emptyset	300 \emptyset	350 \emptyset	

KIRLOSKAR BROTHERS LIMITED

NO. HA17H09AA0-0

PERFORMANCE CURVE OF PUMP i-HT10ED

SUC. 125 mm DEL 100mm

THIS CURVE RELATES TO LIQUID OF SP.GR. = 1.0

n = 2950^{rpm}
(NOMINAL)



Enriching Lives

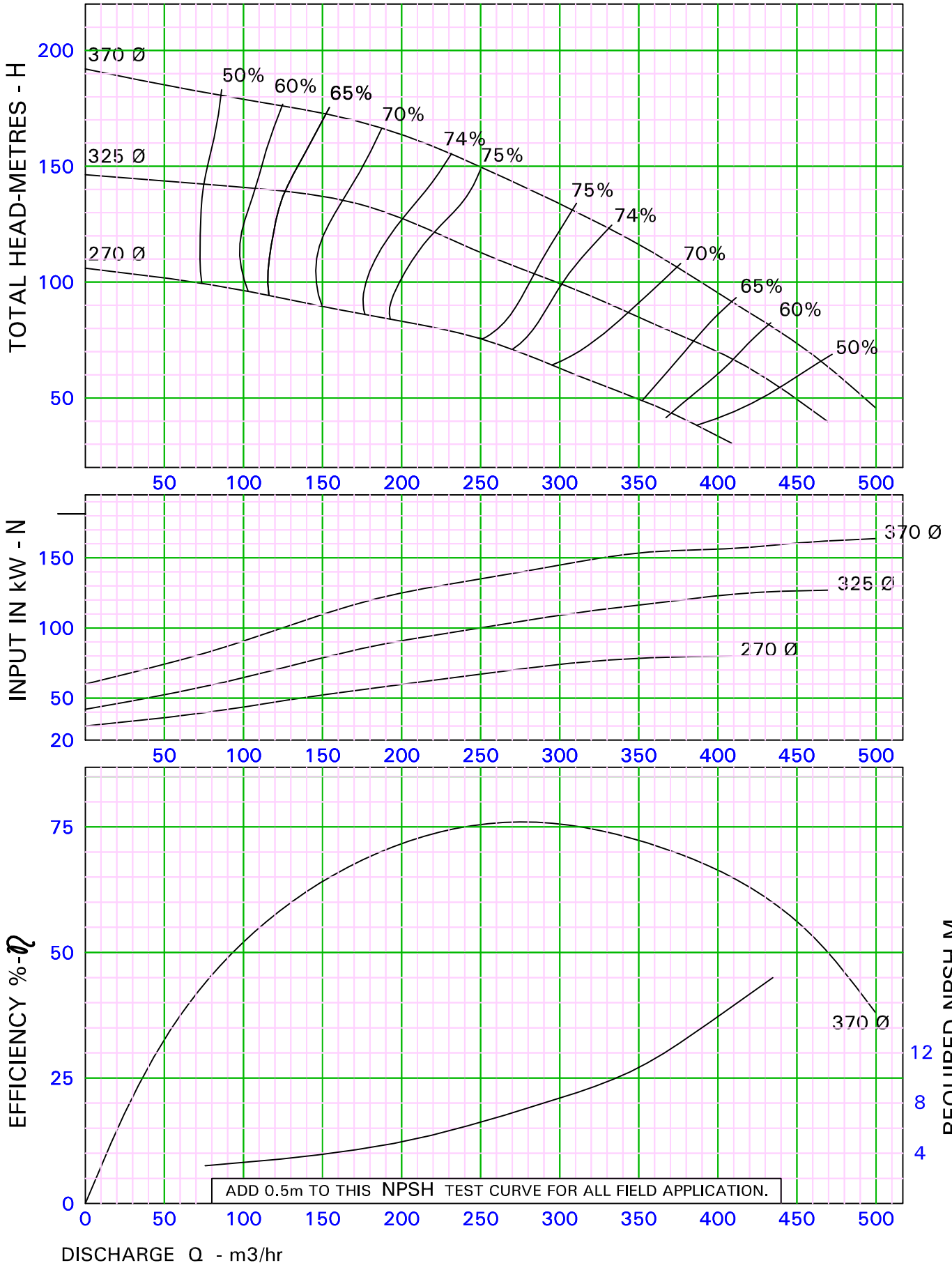

RECOMMENDED DELIVERY PIPE SIZE mm	150Ø	200Ø	250Ø	350Ø
RECOMMENDED SUCTION PIPE SIZE mm	200Ø	250Ø	350Ø	

KIRLOSKAR BROTHERS LIMITED

NO. HA17H08AA0-0



PERFORMANCE CURVE OF PUMP i-HT10DE

SUC. 125 mm DEL 100mm

THIS CURVE RELATES TO LIQUID OF SP.GR. = 1.0

n = 2950 rpm
(NOMINAL)

Enriching Lives

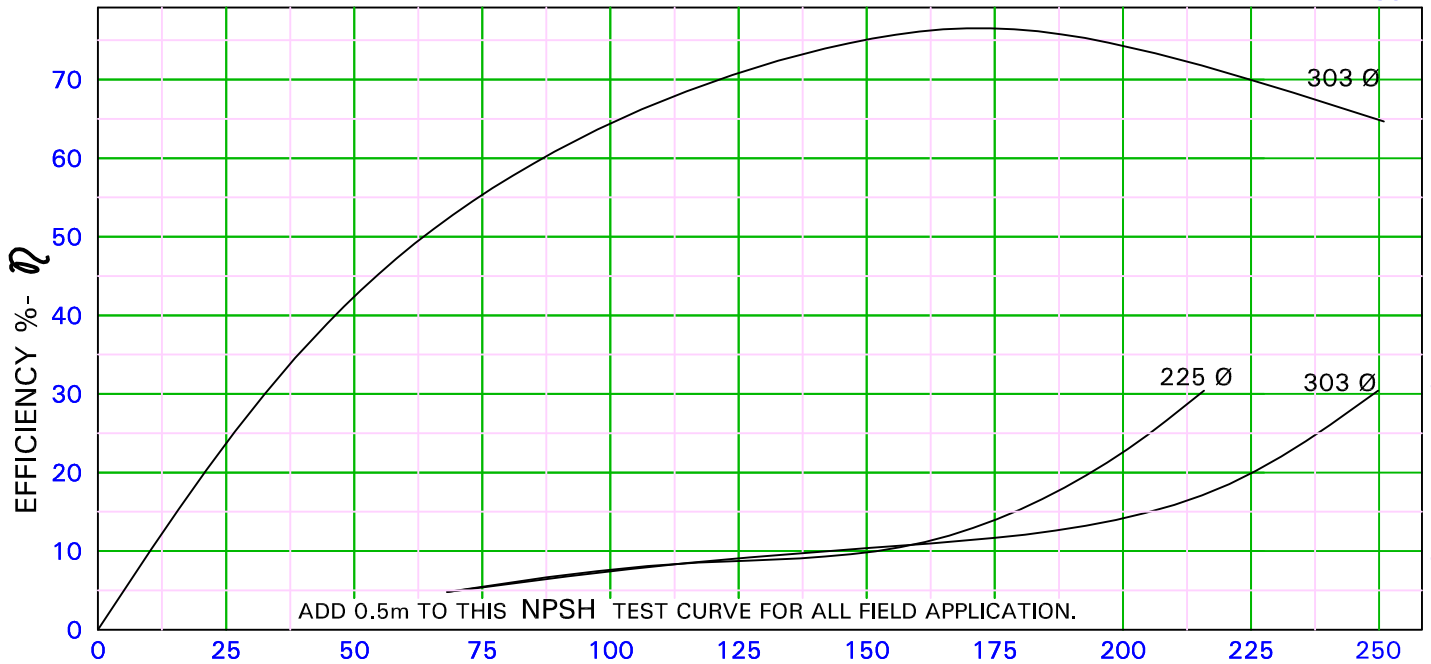
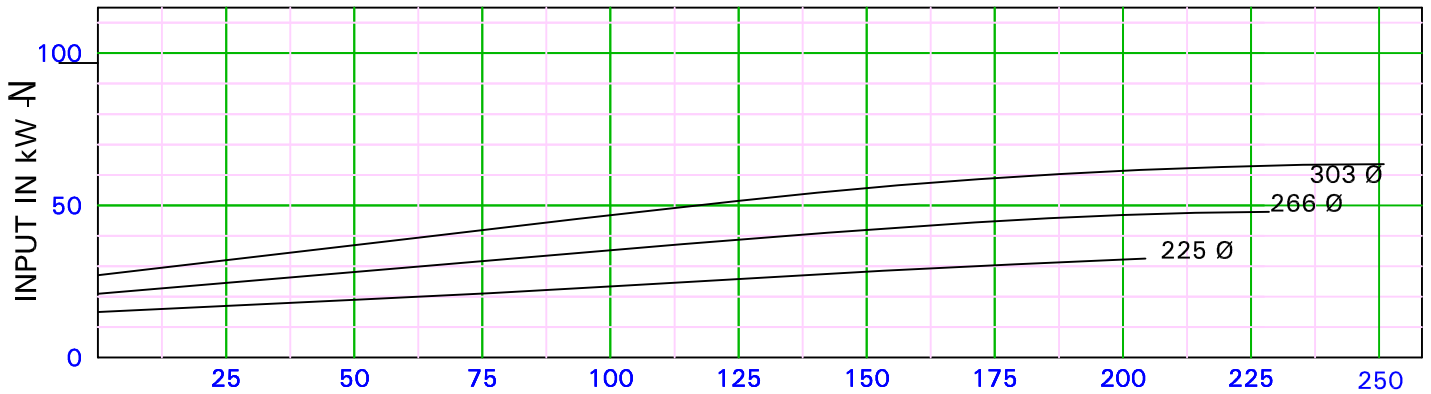
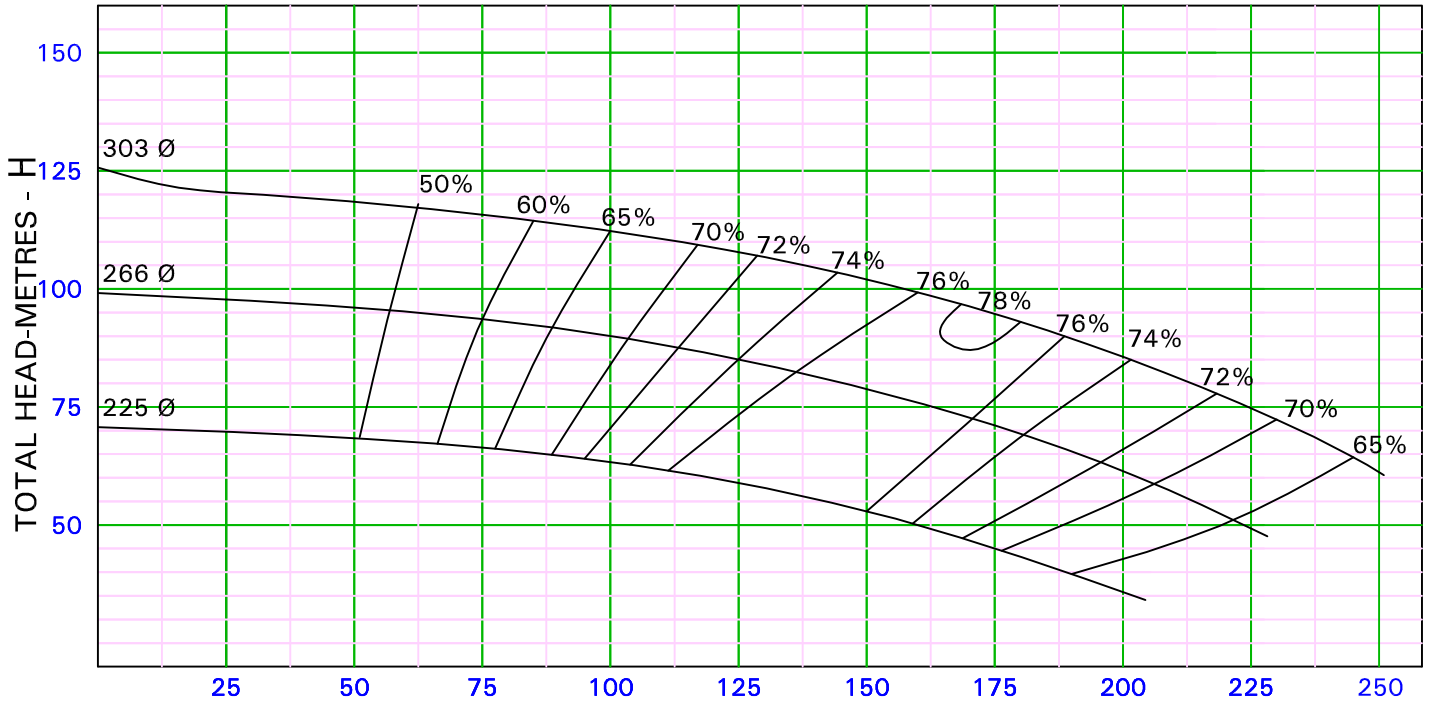

REQUIRED NPSH-M

DISCHARGE Q - m³/hr

RECOMMENDED DELIVERY PIPE SIZE mm	125 Ø	150 Ø	175 Ø	200 Ø
RECOMMENDED SUCTION PIPE SIZE mm	150 Ø	175 Ø	200 Ø	

KIRLOSKAR BROTHERS LIMITED

NO. HA17H07AA0 0

PERFORMANCE CURVE OF PUMP i-HT10BE

SUC. 150 mm DEL 100 mm

THIS CURVE RELATES TO LIQUID OF SP.GR. = 1.0

n = 2950 rpm
(NOMINAL)



Enriching Lives

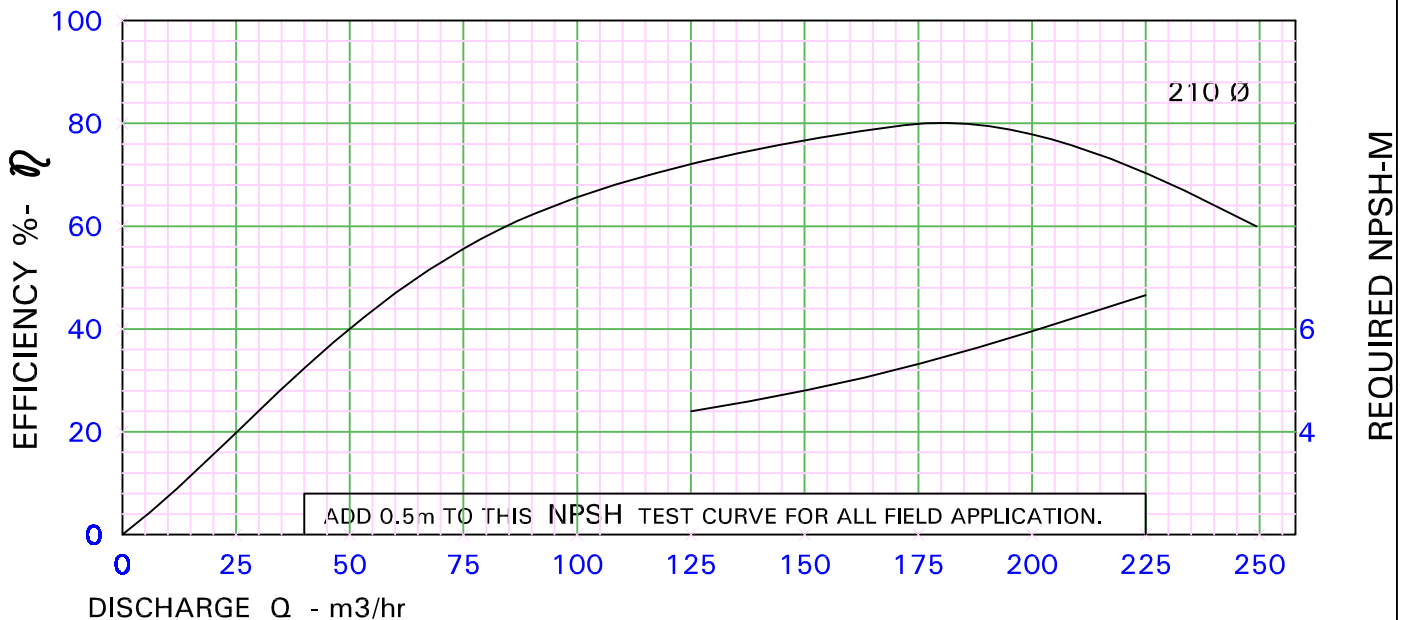
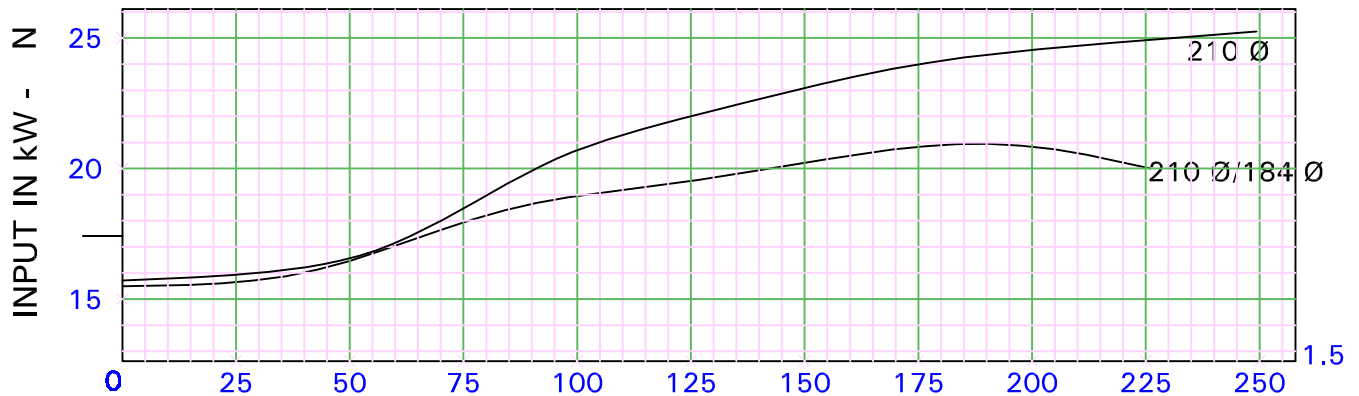
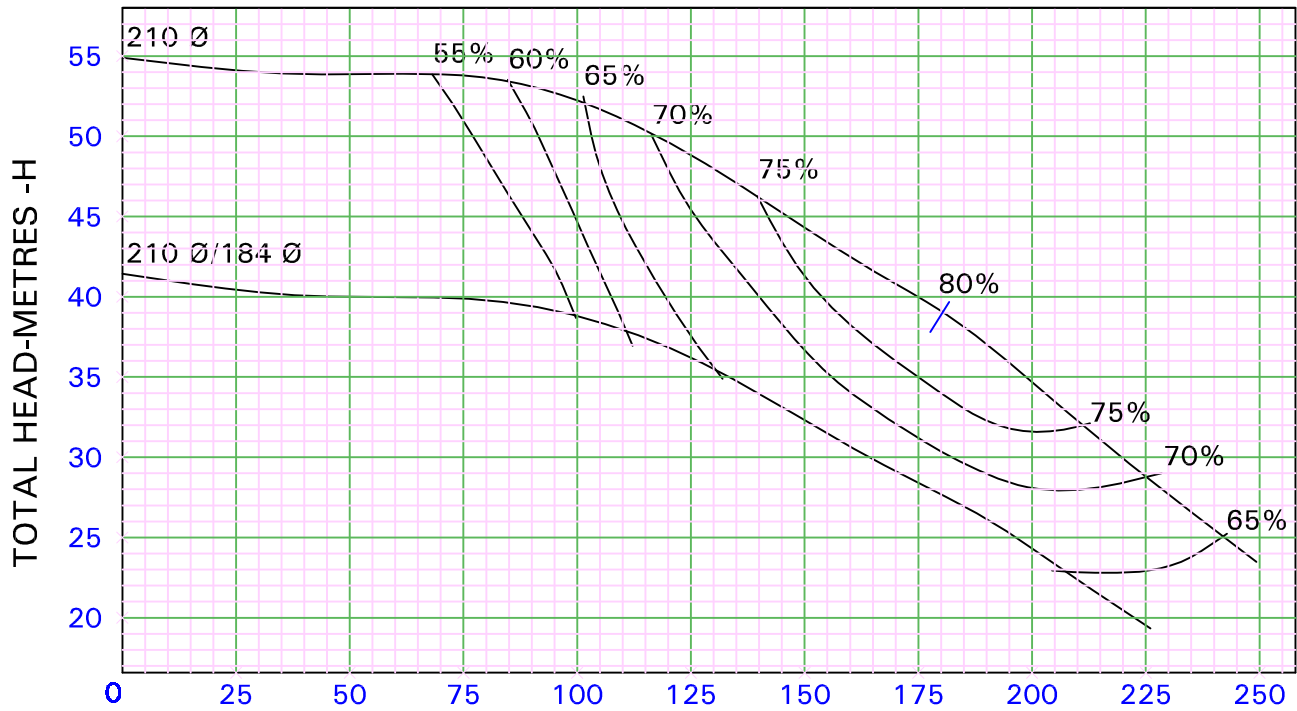

RECOMMENDED DELIVERY PIPE SIZE mm	100 Ø	125 Ø	150 Ø	175 Ø	
RECOMMENDED SUCTION PIPE SIZE mm	150 Ø	175 Ø	200 Ø	250 Ø	

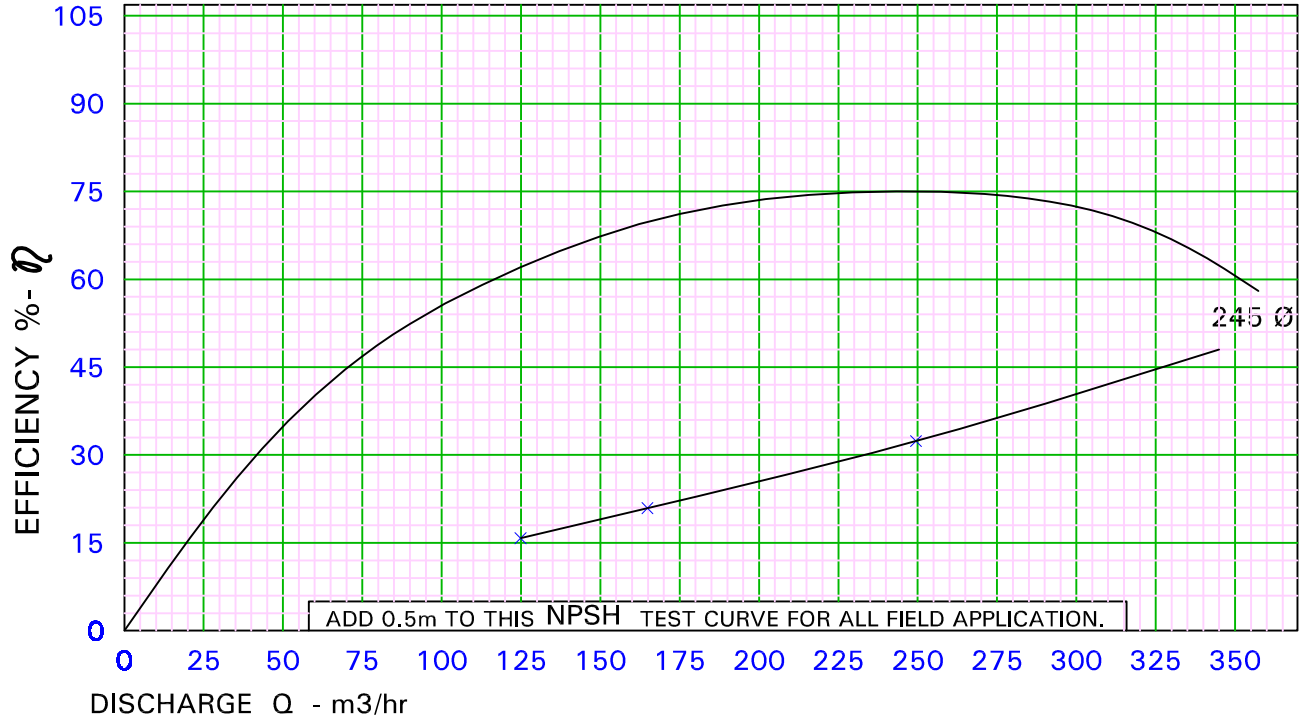
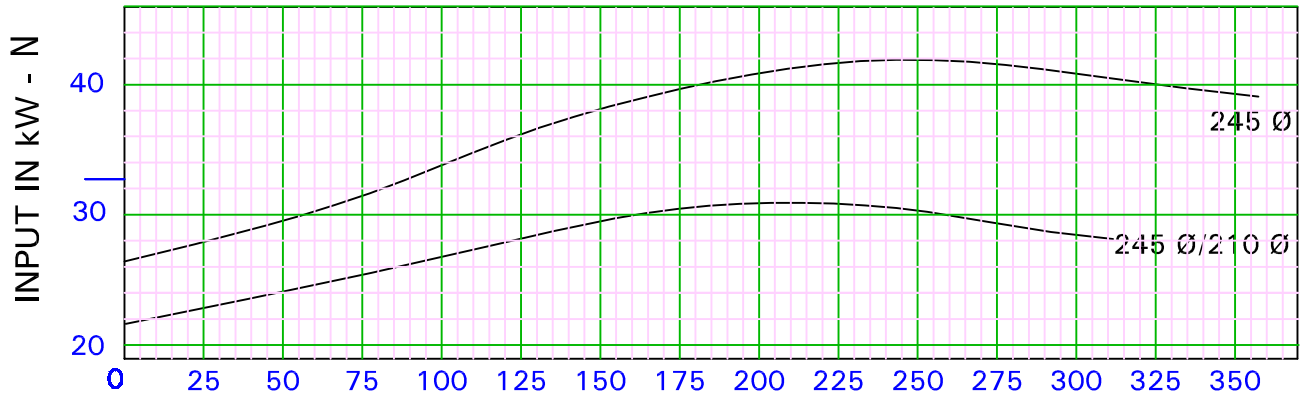
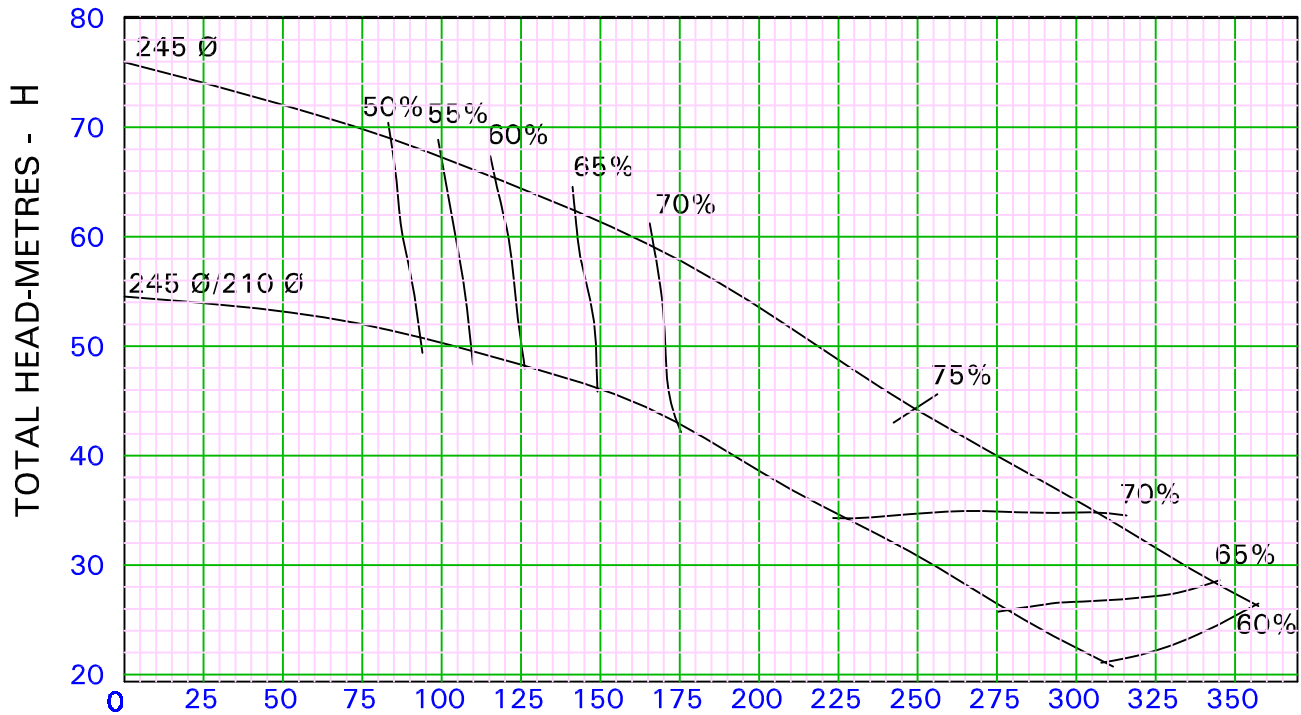

REQUIRED NPSH-M

RECOMMENDED DELIVERY PIPE SIZE mm	125Ø	150Ø	175Ø	200Ø	
RECOMMENDED SUCTION PIPE SIZE mm	150Ø	200Ø		250Ø	300Ø

KIRLOSKAR BROTHERS LIMITED

NO. HA17H05AA0-0

PERFORMANCE CURVE OF PUMP i-HT10BA

SUC. 150 mm DEL 100 mm

THIS CURVE RELATES TO LIQUID OF SP.GR. = 1.0

n = 2900 rpm
(NOMINAL)



Enriching Lives

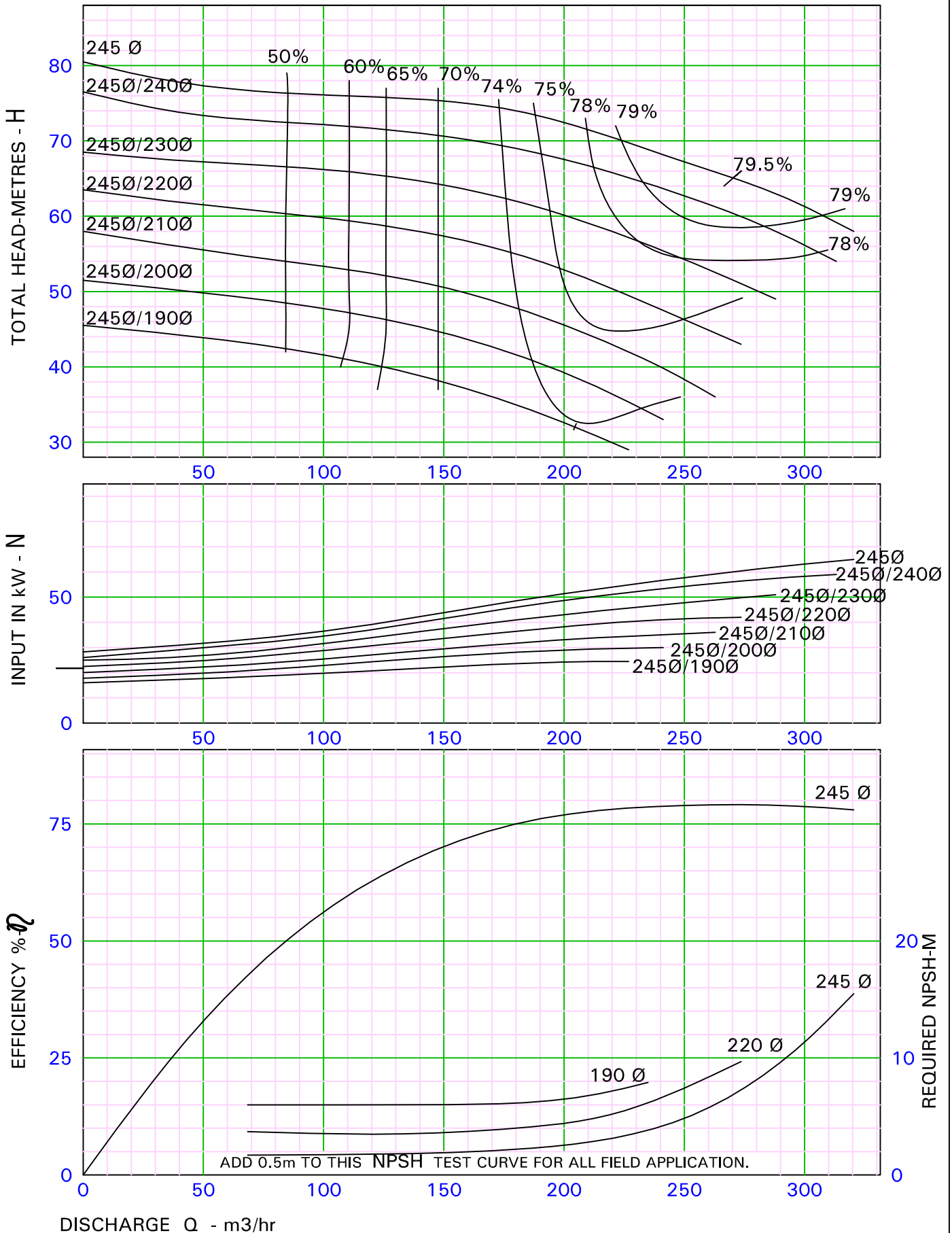

DISCHARGE Q - m³/hr

RECOMMENDED DELIVERY PIPE SIZE mm	125 Ø	150 Ø	175 Ø	200 Ø
RECOMMENDED SUCTION PIPE SIZE mm	150 Ø	200 Ø	250 Ø	

KIRLOSKAR BROTHERS LIMITED

NO. HA17H04AA0 0

PERFORMANCE CURVE OF PUMP *i*-HT08BE

SUC. 100mm DEL 80 mm

THIS CURVE RELATES TO LIQUID OF SP.GR. = 1.0

n = 2950 rpm
(NOMINAL)



Enriching Lives

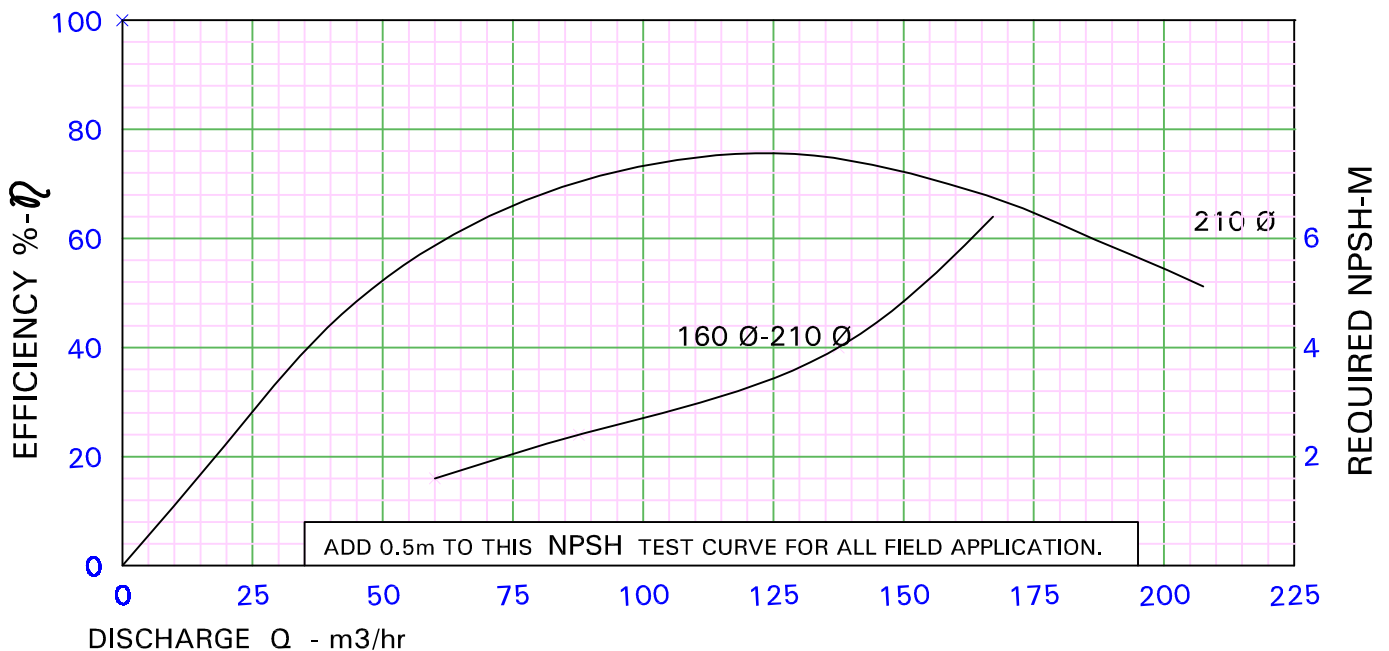
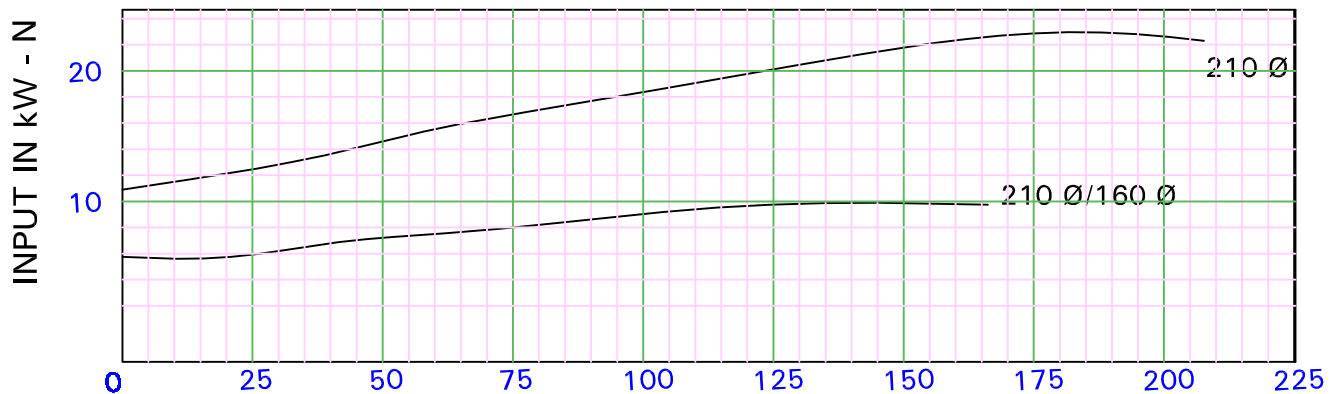
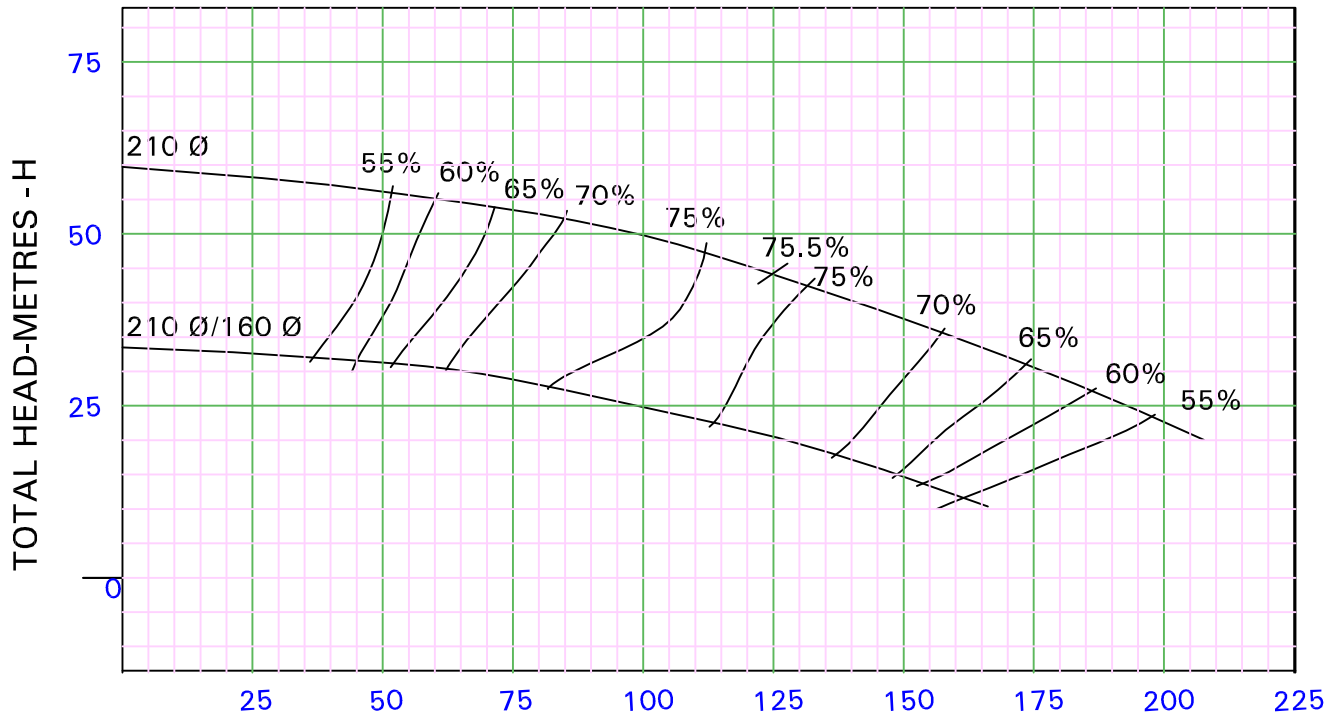

RECOMMENDED DELIVERY PIPE SIZE mm	100 Ø	125 Ø	150 Ø	175 Ø	
RECOMMENDED SUCTION PIPE SIZE mm	125Ø	150 Ø	175Ø	200Ø	250Ø

KIRLOSKAR BROTHERS LIMITED

NO. HA17H03AA0 0

PERFORMANCE CURVE OF PUMP i-HT08BD

SUC. 100mm DEL 80 mm

THIS CURVE RELATES TO LIQUID OF SP.GR. = 1.0

n = 2950 rpm
(NOMINAL)



Enriching Lives

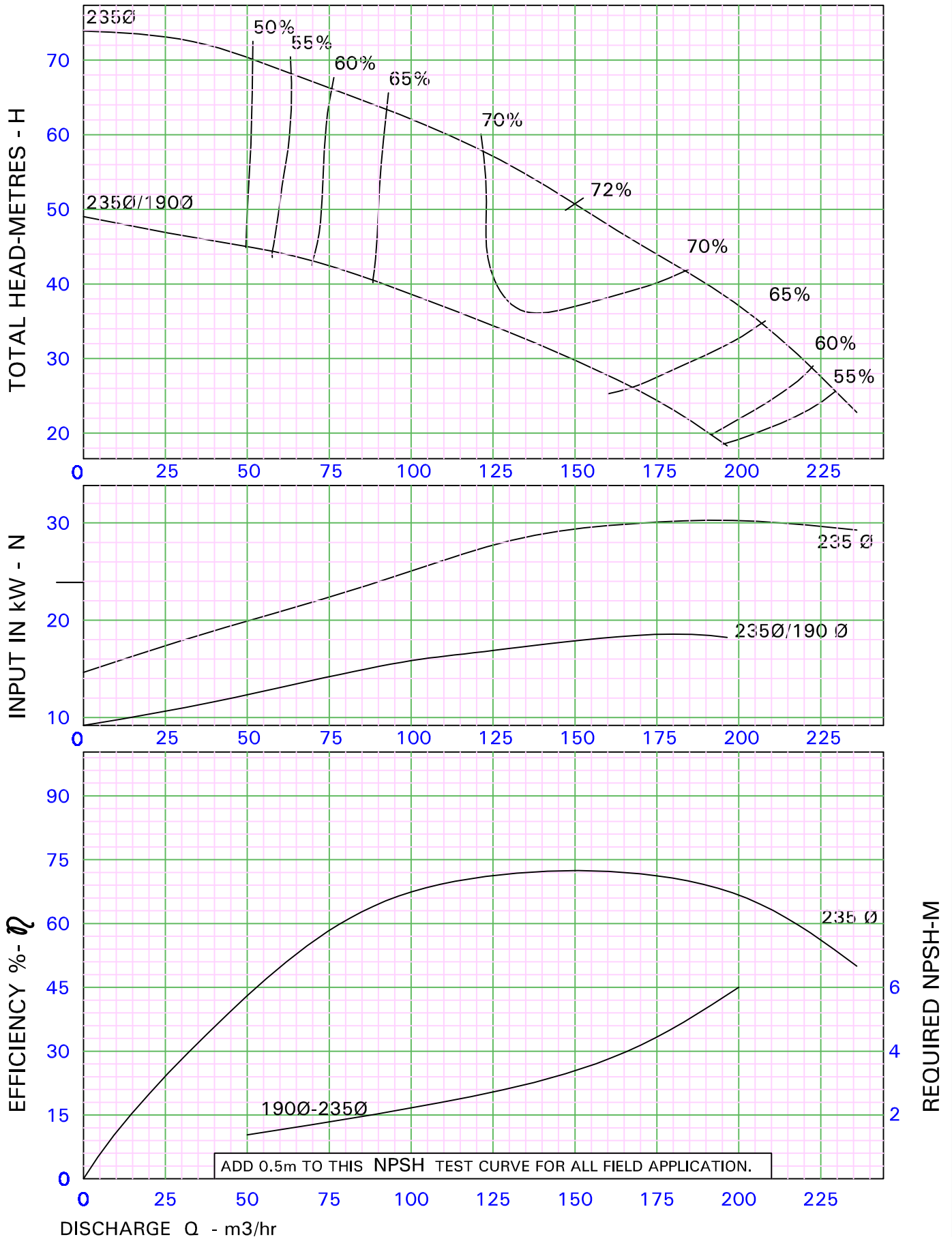

RECOMMENDED DELIVERY PIPE SIZE mm	100Ø	125Ø	150Ø	175Ø	200Ø	250Ø
RECOMMENDED SUCTION PIPE SIZE mm	125Ø	150Ø	175Ø	200Ø	250Ø	

KIRLOSKAR BROTHERS LIMITED

NO. HA17H02AA0-0

PERFORMANCE CURVE OF PUMP i-HT08BA

SUC. 100 mm DEL 80 mm

THIS CURVE RELATES TO LIQUID OF SP.GR. = 1.0

n = 2900 rpm
(NOMINAL)



Enriching Lives

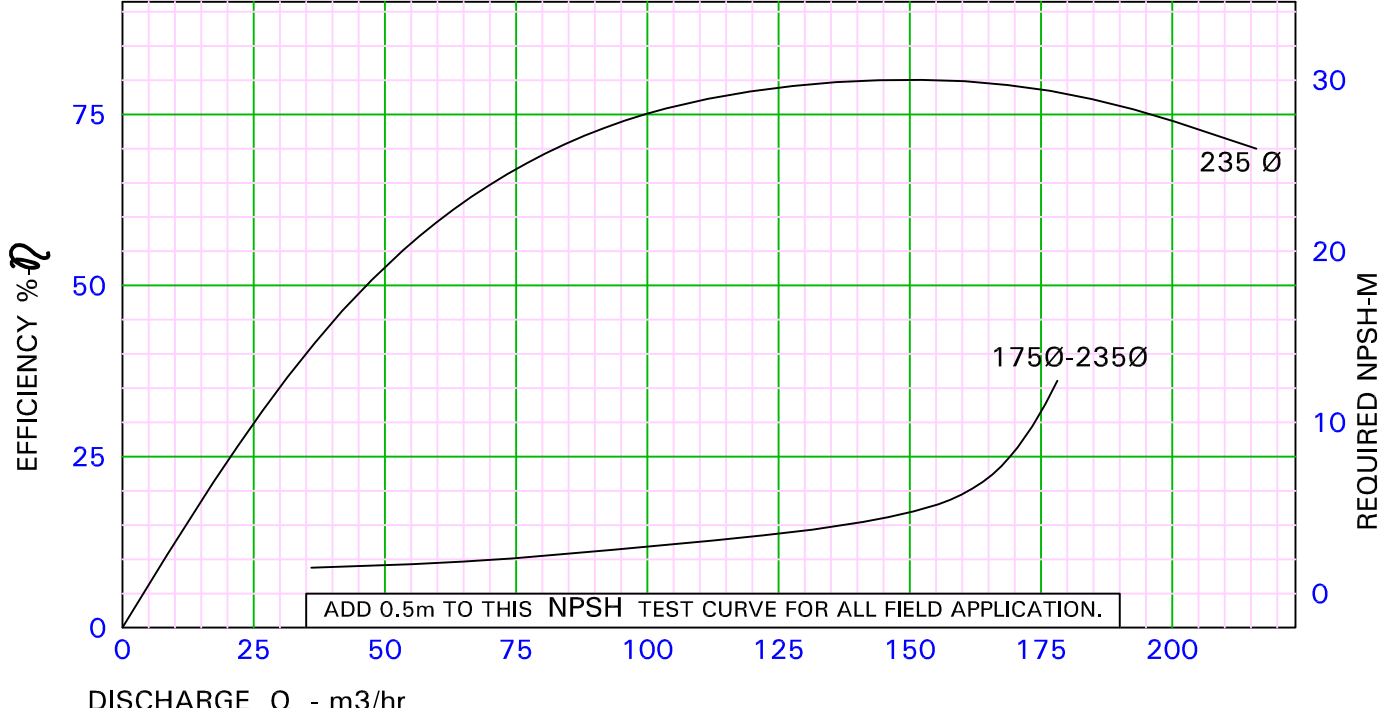
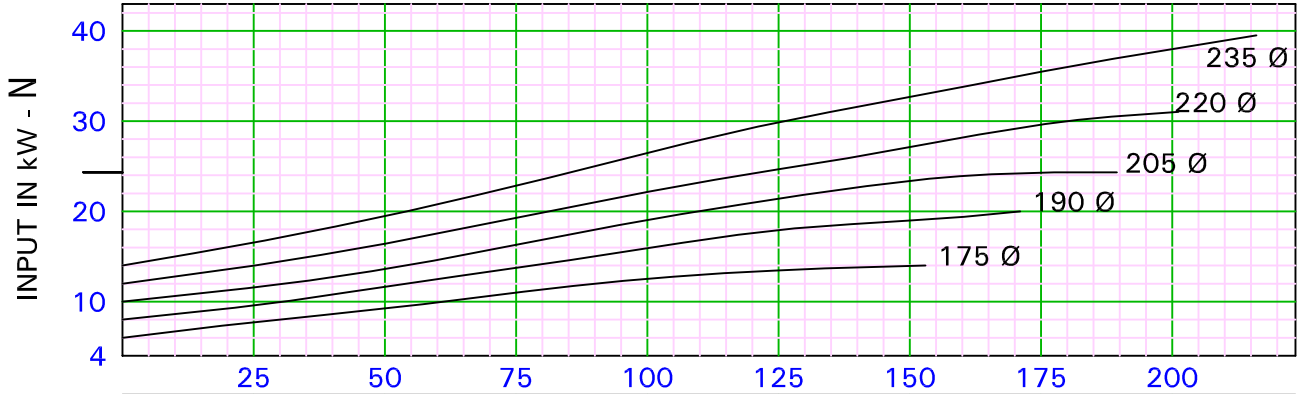
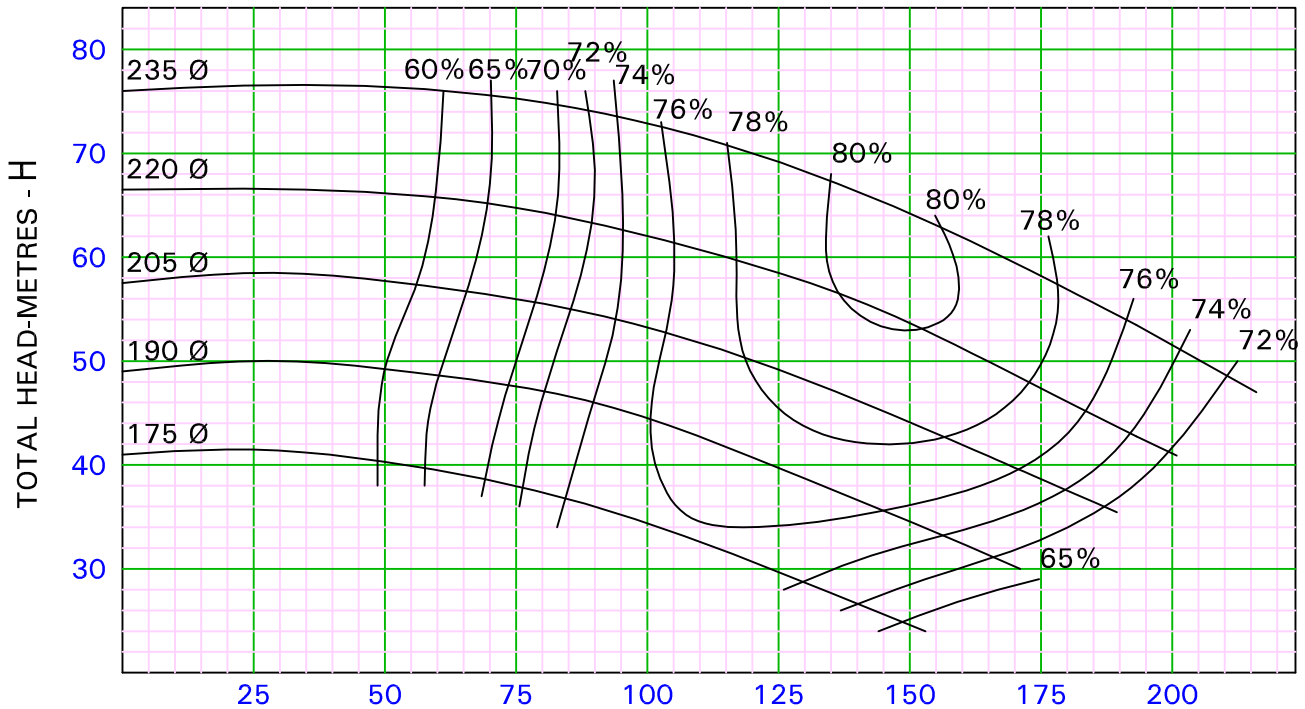

RECOMMENDED DELIVERY PIPE SIZE mm	100 Ø	125 Ø	150 Ø	175 Ø
RECOMMENDED SUCTION PIPE SIZE mm	125 Ø	150 Ø	175 Ø	200 Ø

KIRLOSKAR BROTHERS LIMITED

NO. HA17H01AA0-0



Enriching Lives

PERFORMANCE CURVE OF PUMP i-HT06BA

SUC. 80 mm DEL 65 mm

THIS CURVE RELATES TO LIQUID OF SP.GR. = 1.0

n = 2900 rpm
(NOMINAL)

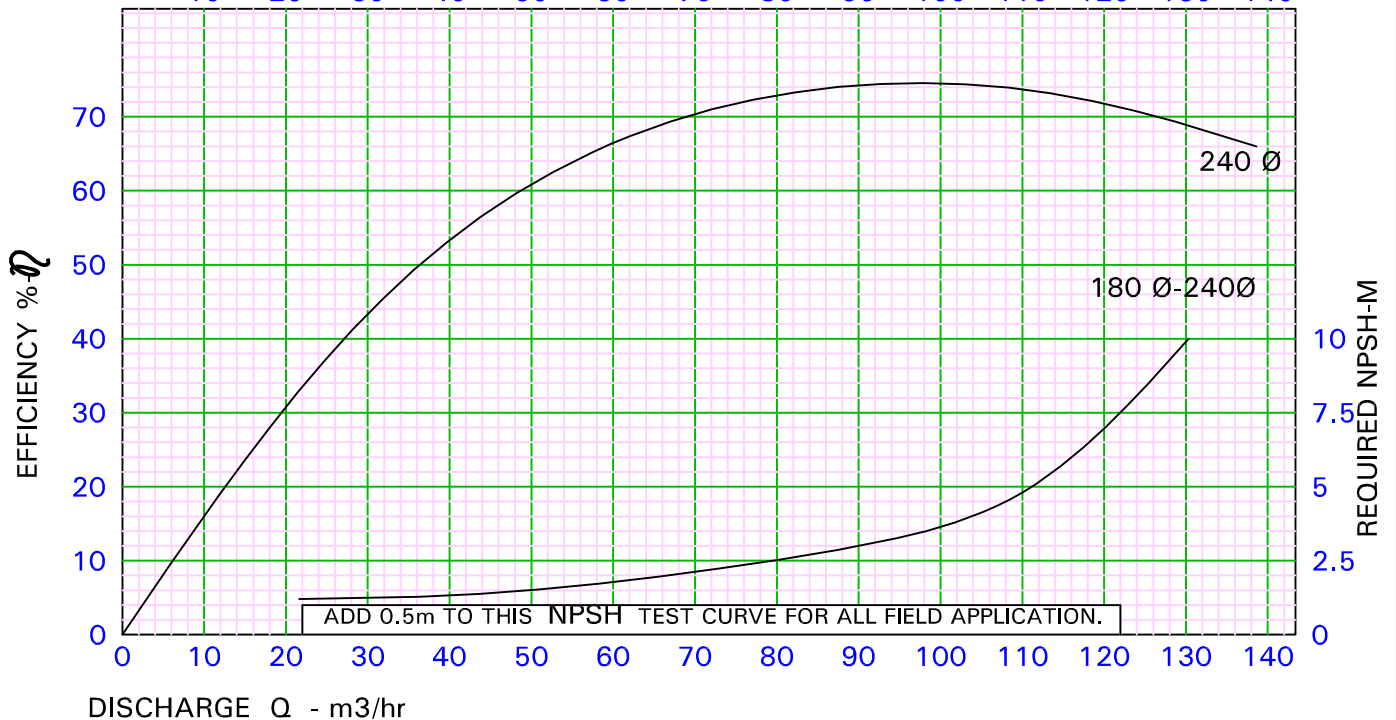
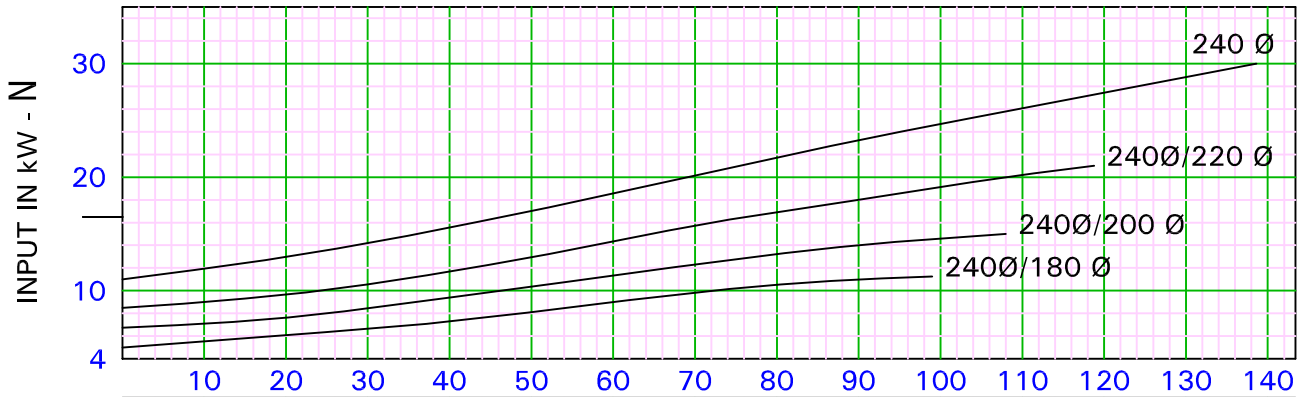
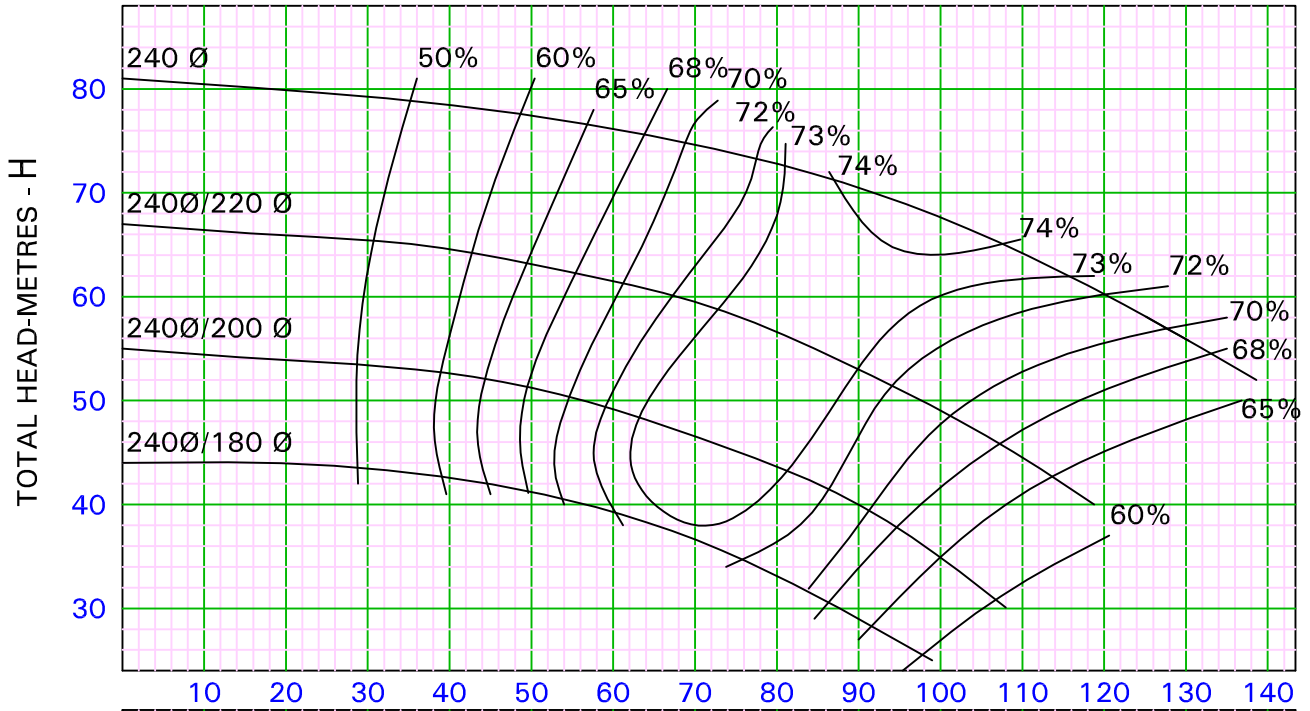

RECOMMENDED DELIVERY PIPE SIZE mm	80 Ø	100 Ø	125 Ø	
RECOMMENDED SUCTION PIPE SIZE mm	100 Ø	125 Ø	150 Ø	175 Ø

KIRLOSKAR BROTHERS LIMITED

NO. HA17H01AA0-0



Enriching Lives

PERFORMANCE CURVE OF PUMP i-HT06BA

SUC. 80 mm DEL 65 mm

THIS CURVE RELATES TO LIQUID OF SP.GR. = 1.0

n = 2900 rpm
(NOMINAL)

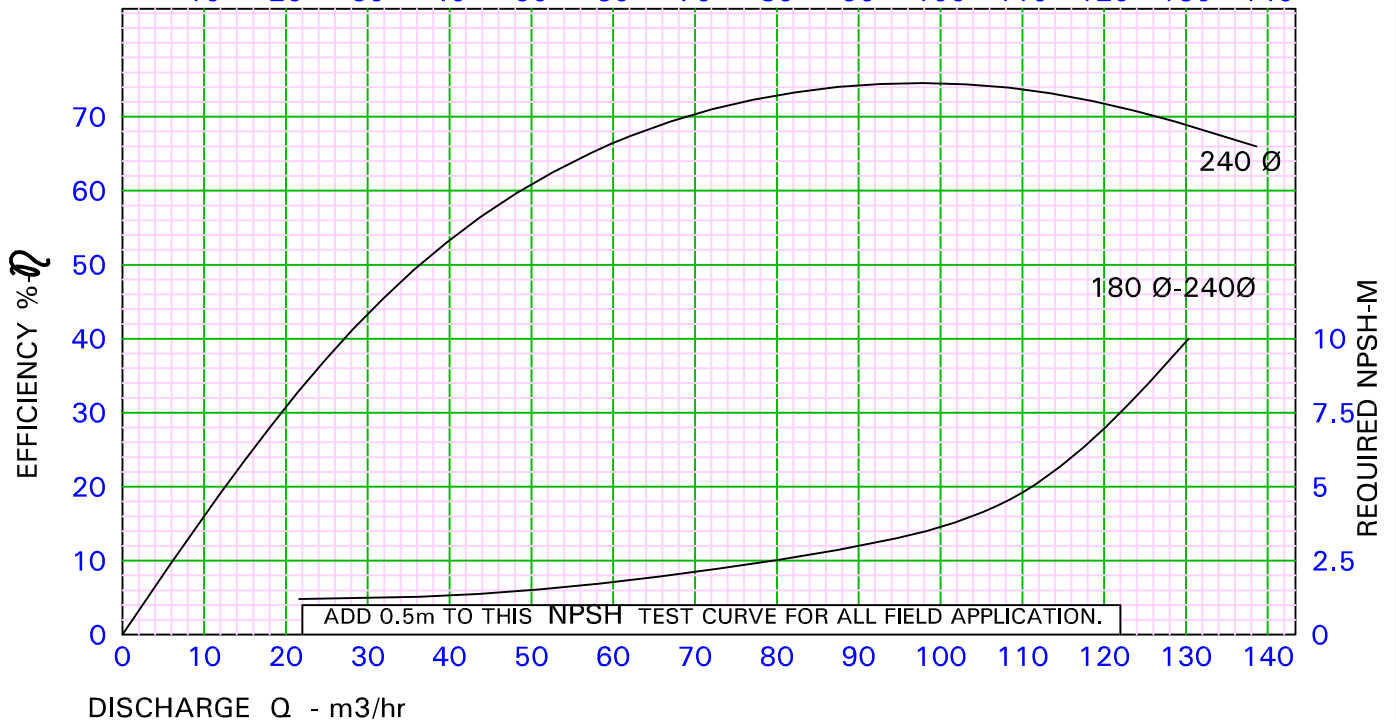
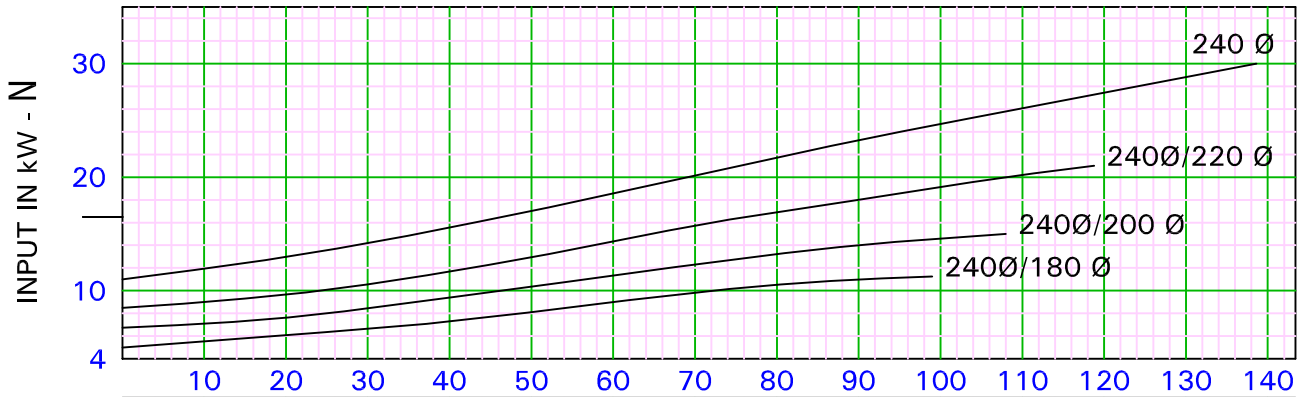
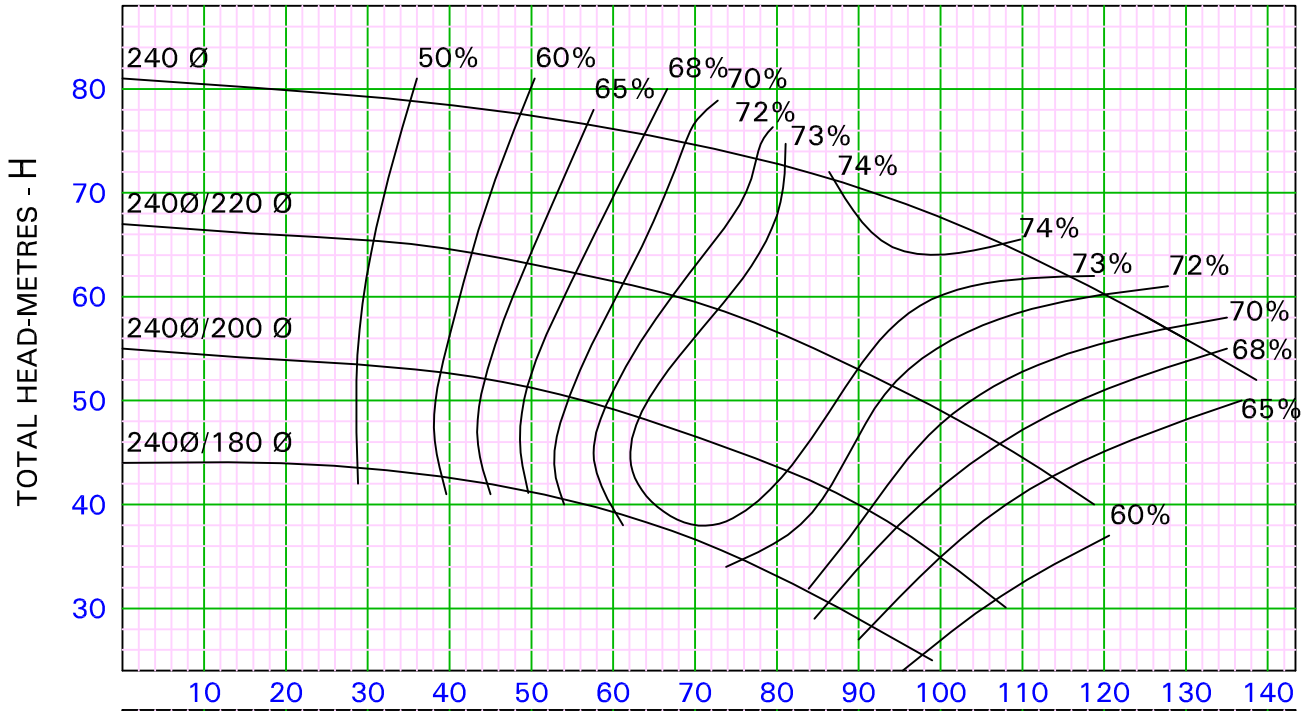

RECOMMENDED DELIVERY PIPE SIZE mm	80 Ø	100 Ø	125 Ø	
RECOMMENDED SUCTION PIPE SIZE mm	100 Ø	125 Ø	150 Ø	175 Ø

KIRLOSKAR BROTHERS LIMITED

NO. HA17H31AAO 0

PERFORMANCE CURVE OF PUMP i-HT06AA(2ST)

SUC. 100mm DEL 65 mm

THIS CURVE RELATES TO LIQUID OF SP.GR. = 1.0

n = 2900^{rpm}
(NOMINAL)



Enriching Lives

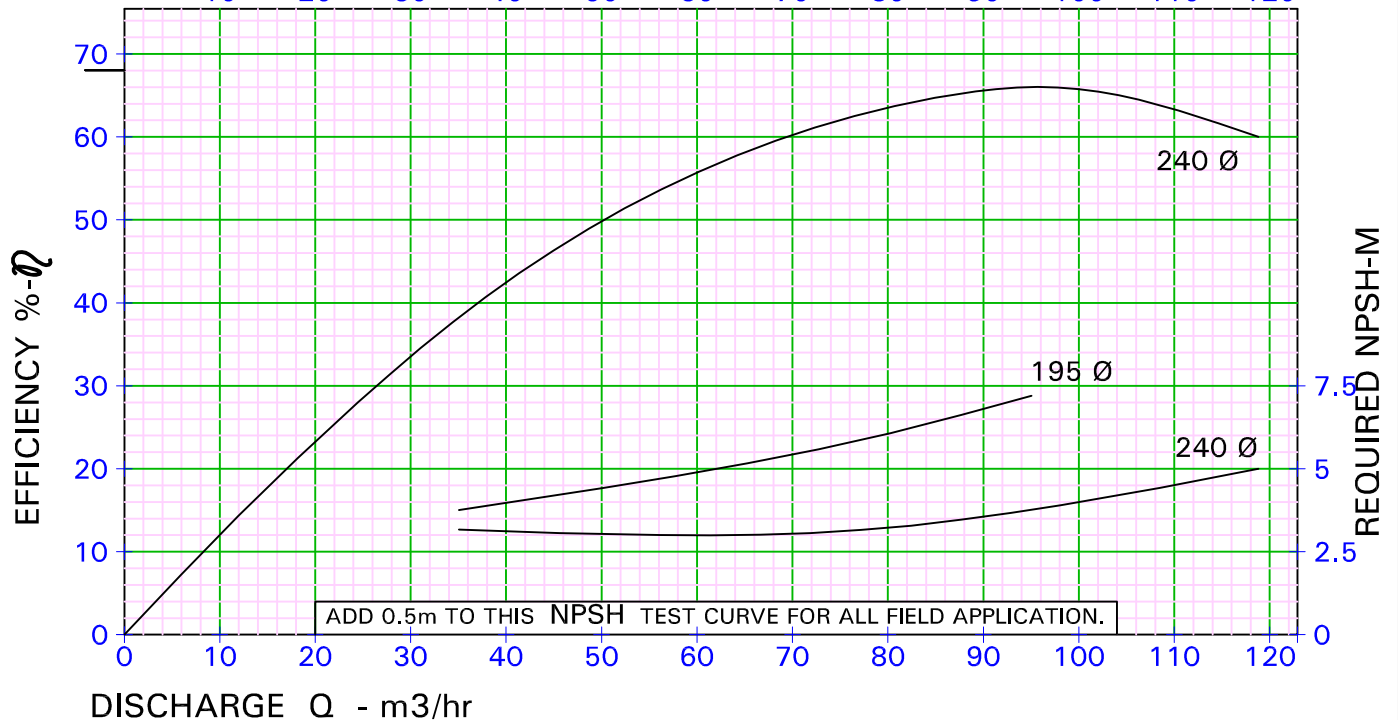
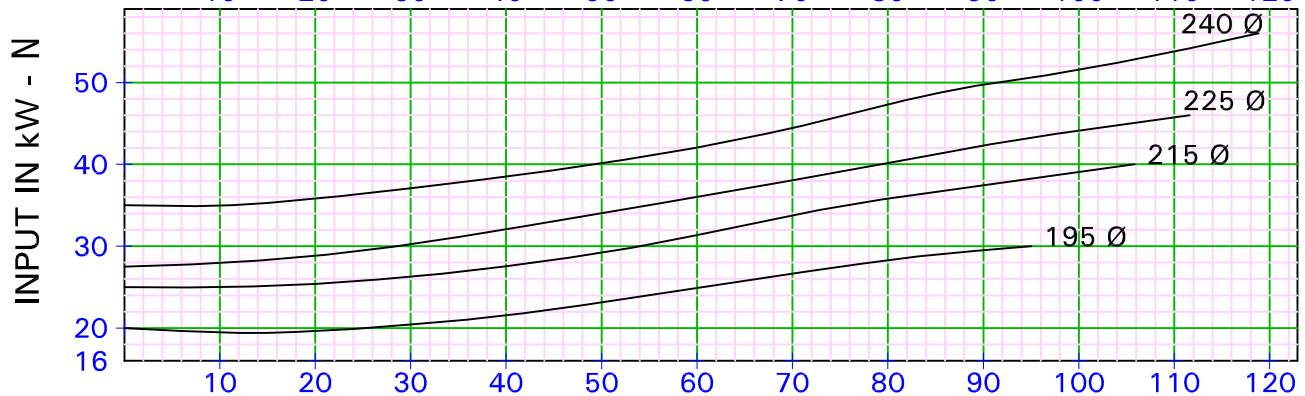
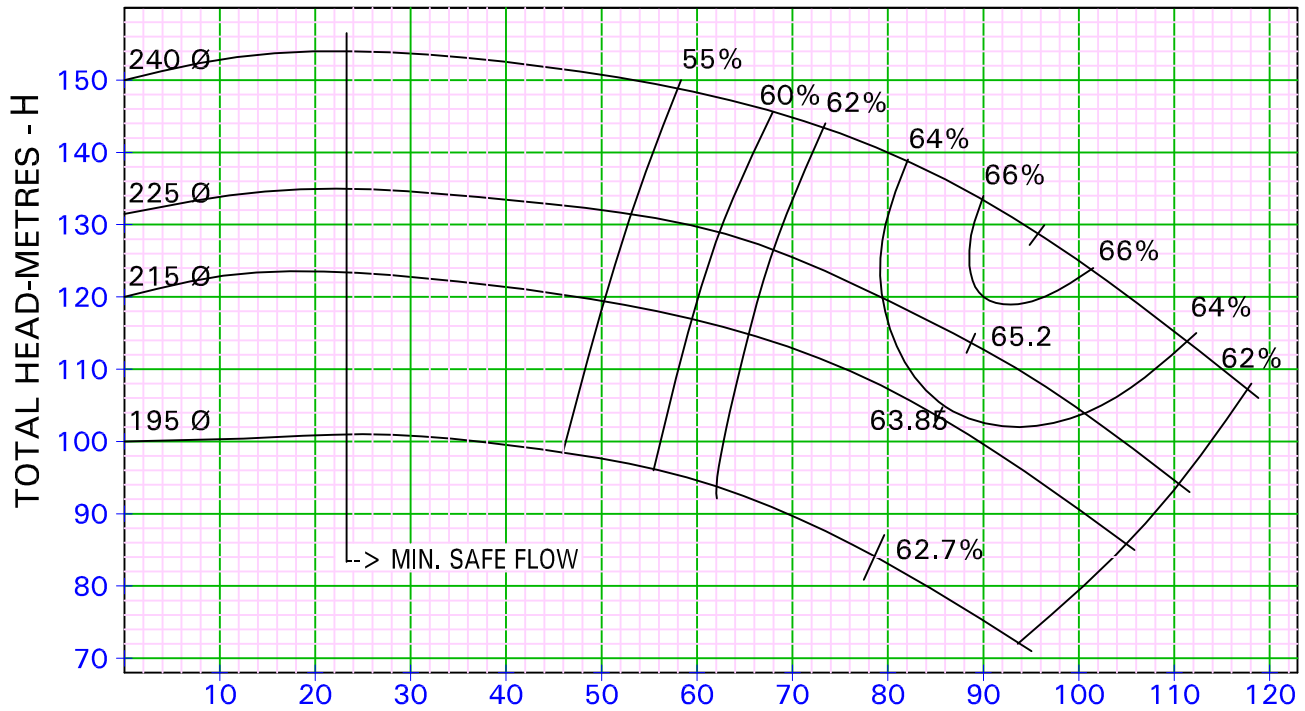

ADD 0.5m TO THIS NPSH TEST CURVE FOR ALL FIELD APPLICATION.

DISCHARGE Q - m3/hr

RECOMMENDED DELIVERY PIPE SIZE mm	100 Ø	125 Ø	150 Ø
RECOMMENDED SUCTION PIPE SIZE mm	100 Ø	125 Ø	150 Ø

KIRLOSKAR BROTHERS LIMITED

NO. HA17H31AAO 0

PERFORMANCE CURVE OF PUMP i-HT06AA(2ST)

SUC. 100mm DEL 65 mm

THIS CURVE RELATES TO LIQUID OF SP.GR. = 1.0

n = 2900^{rpm}
(NOMINAL)



Enriching Lives

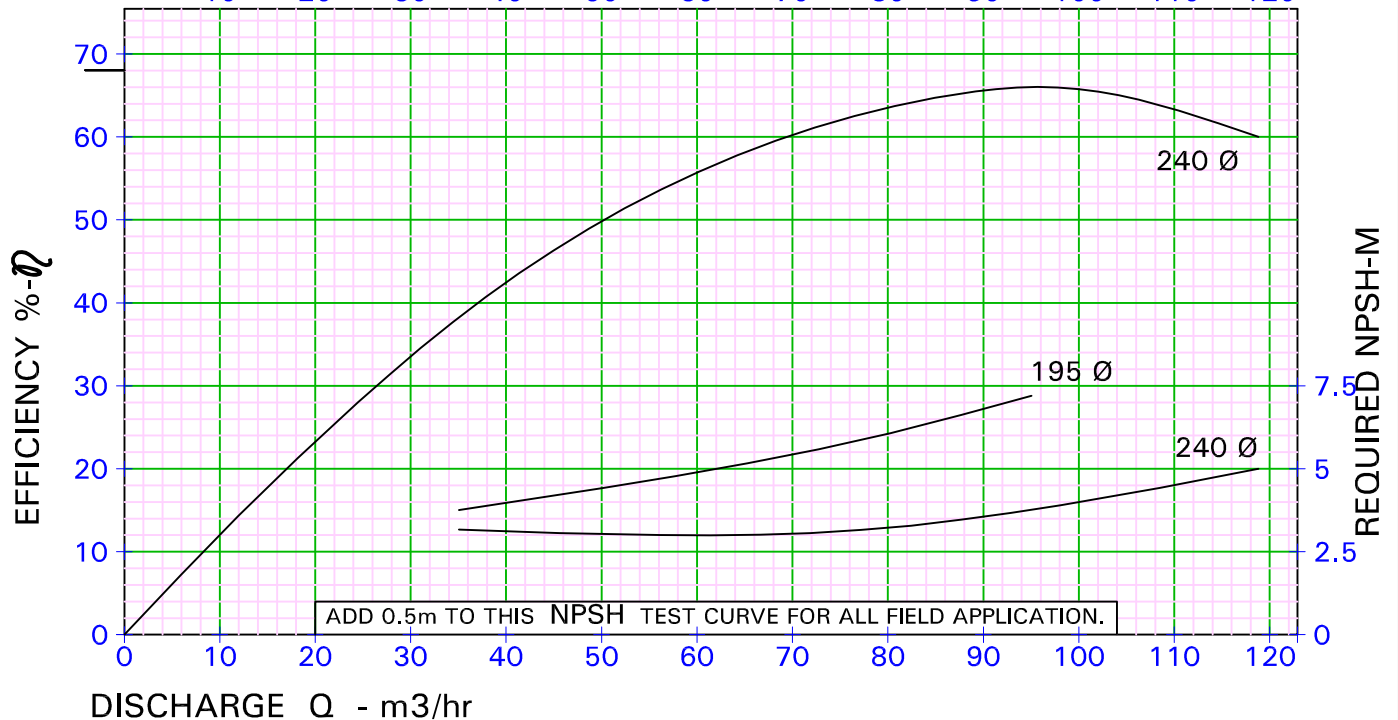
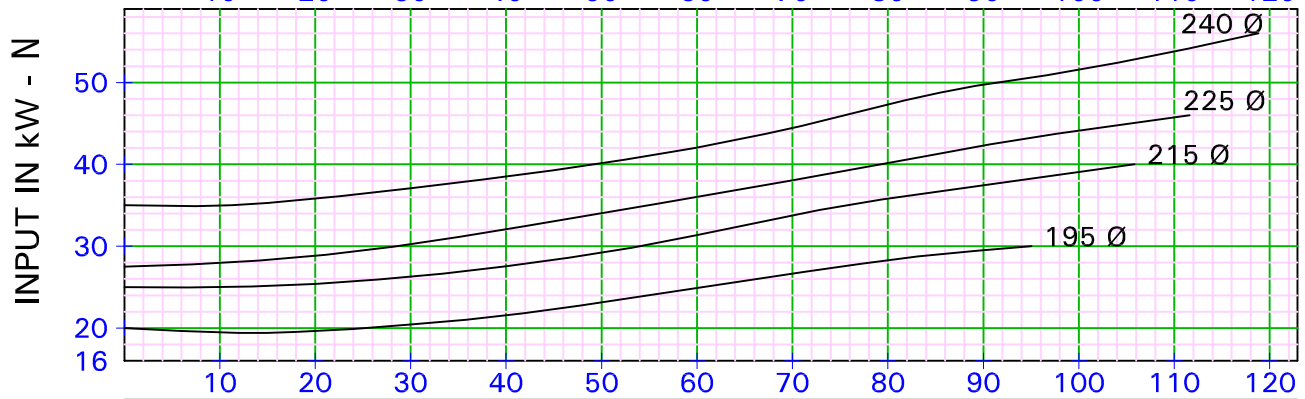
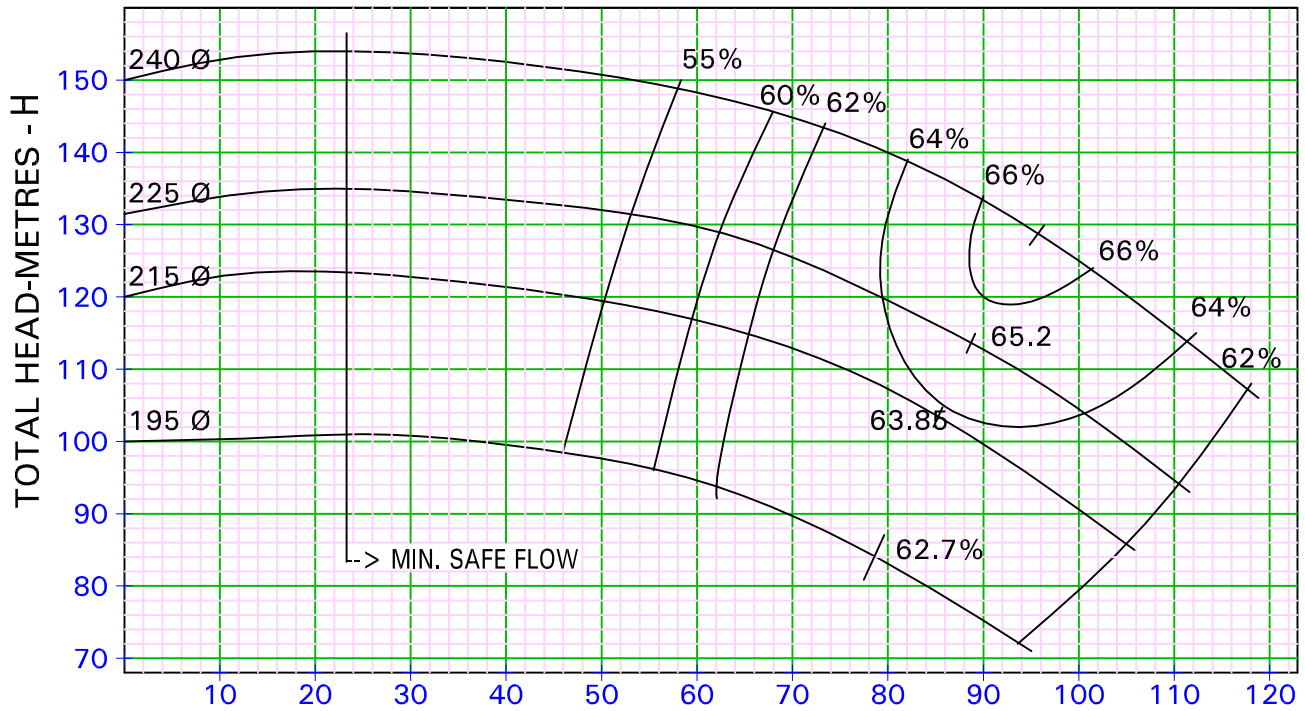

ADD 0.5m TO THIS NPSH TEST CURVE FOR ALL FIELD APPLICATION.

DISCHARGE Q - m3/hr

RECOMMENDED DELIVERY PIPE SIZE mm	100 Ø	125 Ø	150 Ø
RECOMMENDED SUCTION PIPE SIZE mm	100 Ø	125 Ø	150 Ø

KIRLOSKAR BROTHERS LIMITED

NO. HA17H30AAO 0

PERFORMANCE CURVE OF PUMP i-HT05AA(2ST)

SUC. 80 mm DEL 50 mm

THIS CURVE RELATES TO LIQUID OF SP.GR. = 1.0

n = 2900 rpm
(NOMINAL)



Enriching Lives

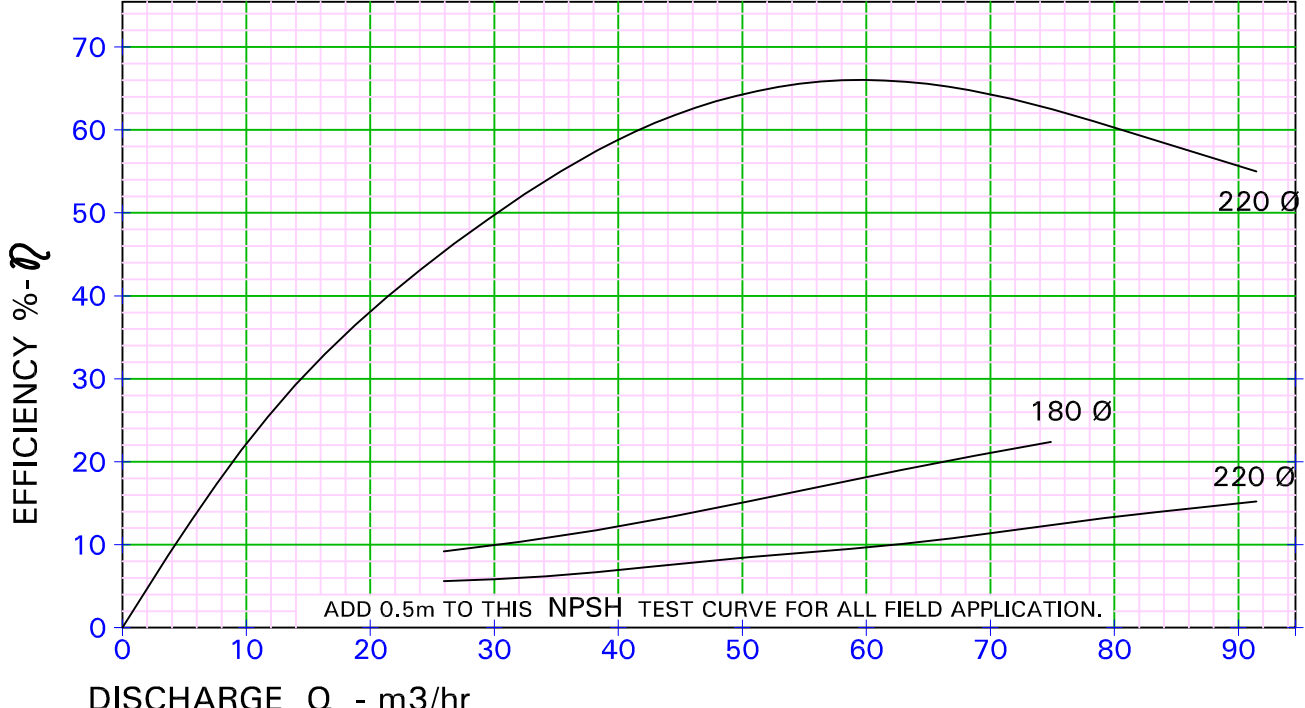
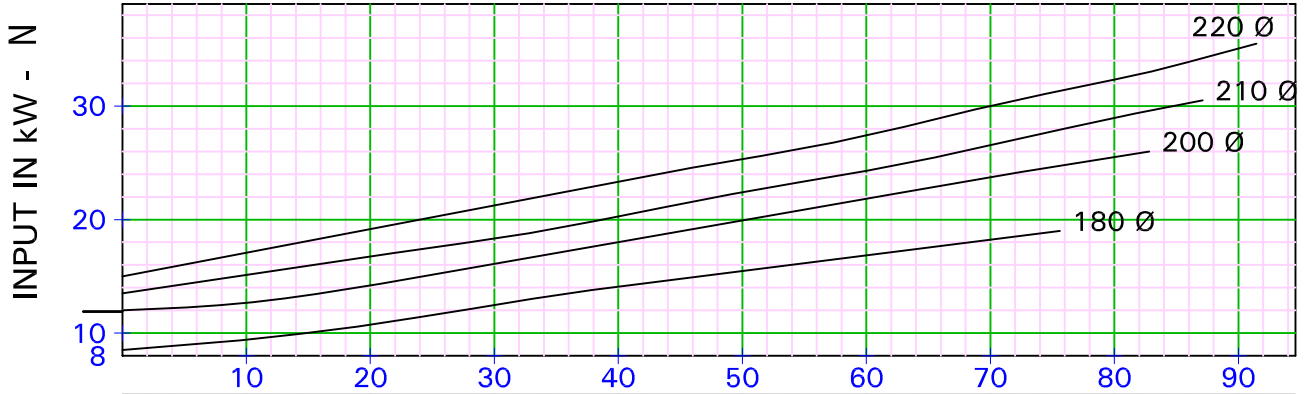
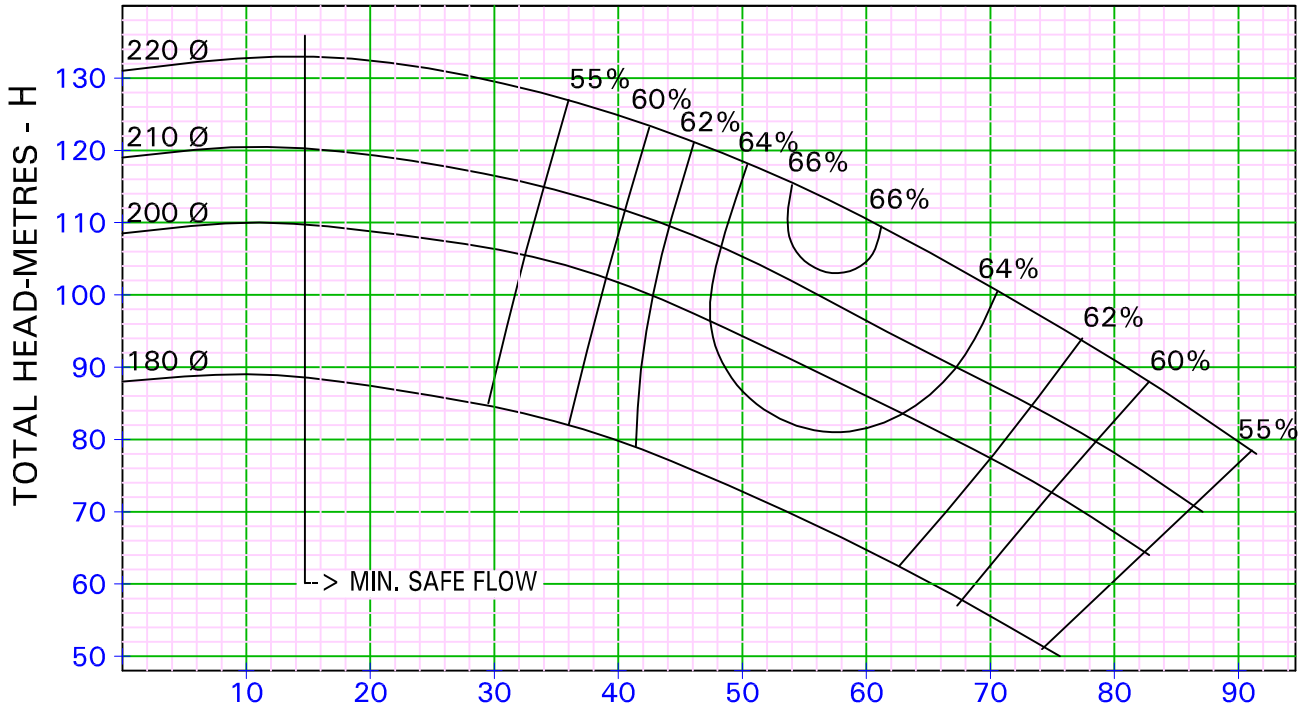

DISCHARGE Q - m3/hr

RECOMMENDED DELIVERY PIPE SIZE mm	100 Ø	125 Ø	150 Ø
RECOMMENDED SUCTION PIPE SIZE mm	100 Ø	125 Ø	150 Ø

KIRLOSKAR BROTHERS LIMITED

NO. HA17H30AAO 0

PERFORMANCE CURVE OF PUMP i-HT05AA(2ST)

SUC. 80 mm DEL 50 mm

THIS CURVE RELATES TO LIQUID OF SP.GR. = 1.0

n = 2900 rpm
(NOMINAL)



Enriching Lives

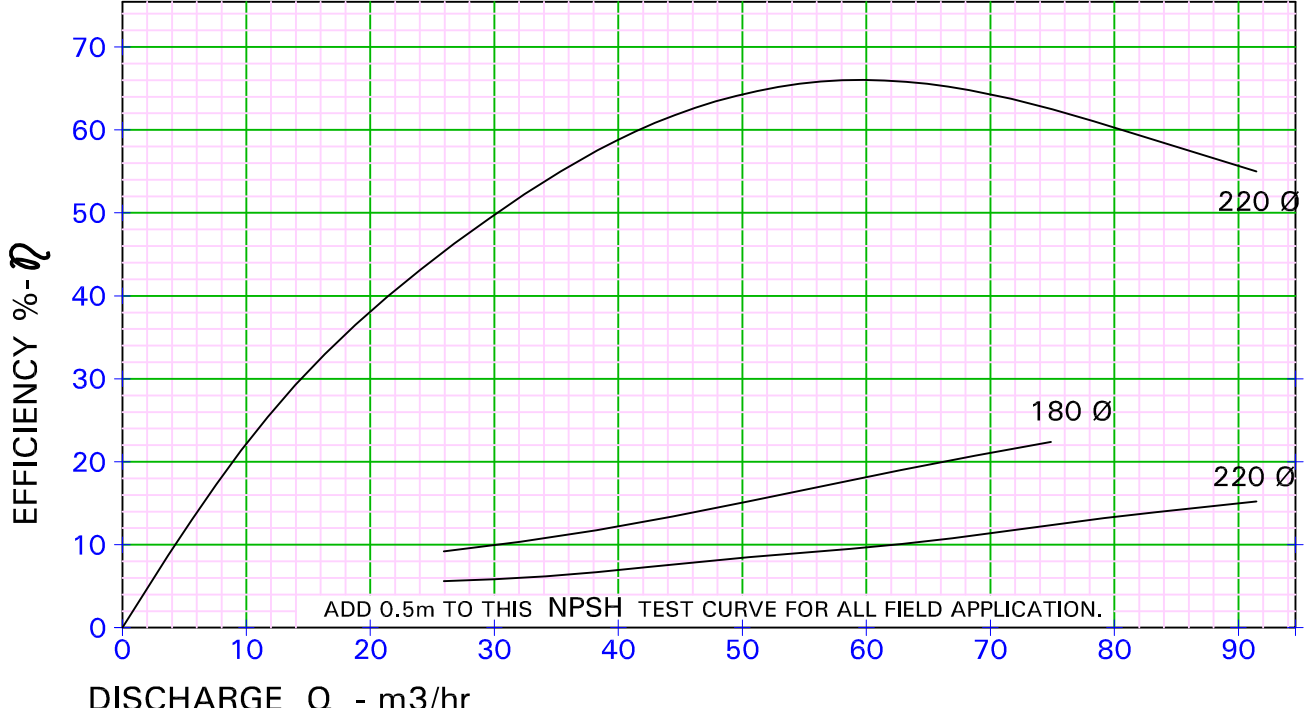
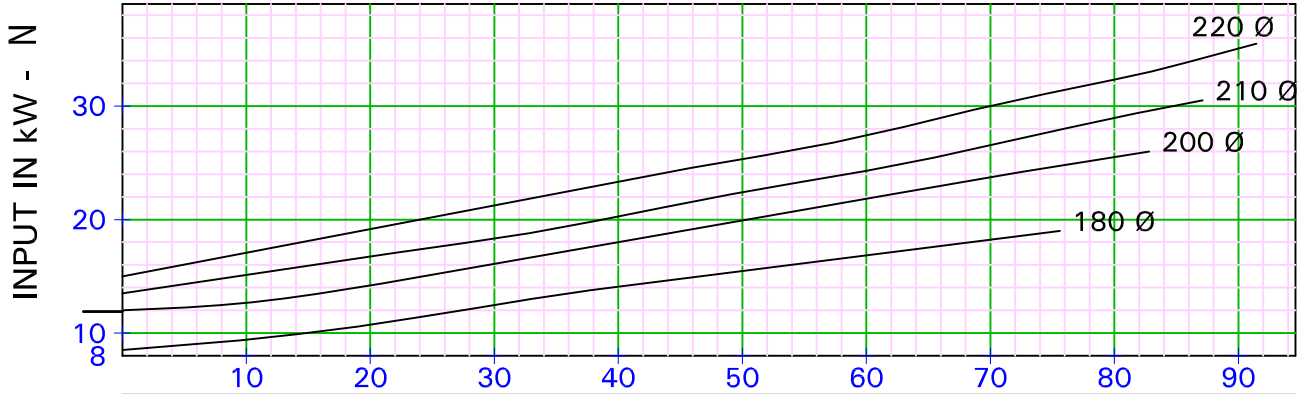
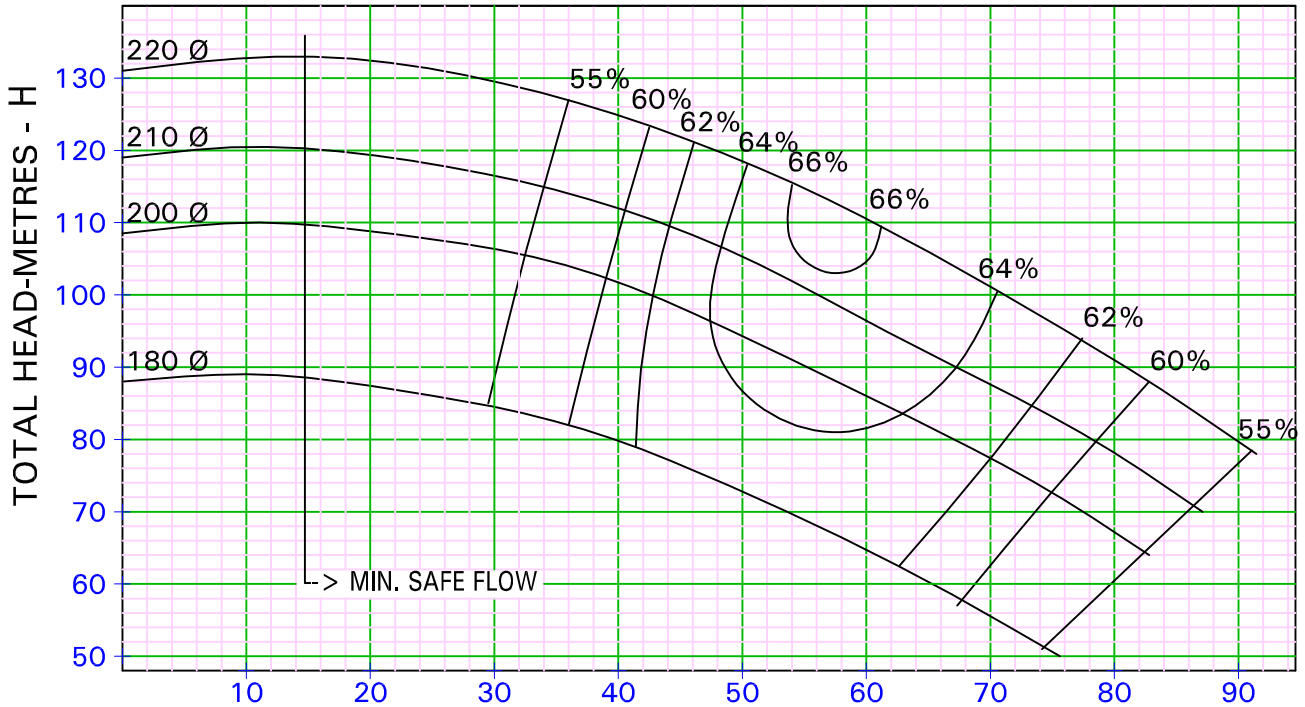

DISCHARGE Q - m3/hr

RECOMMENDED DELIVERY PIPE SIZE mm	100 Ø	125 Ø	150 Ø
RECOMMENDED SUCTION PIPE SIZE mm	100 Ø	125 Ø	150 Ø

KIRLOSKAR BROTHERS LIMITED

NO. HA17H26AA0-0



Enriching Lives

PERFORMANCE CURVE OF PUMP *i*-HT20ED

SUC. 250mm DEL 200mm

n = 2950 rpm (NOMINAL)

THIS CURVE RELATES TO LIQUID OF SP.GR. = 1.0

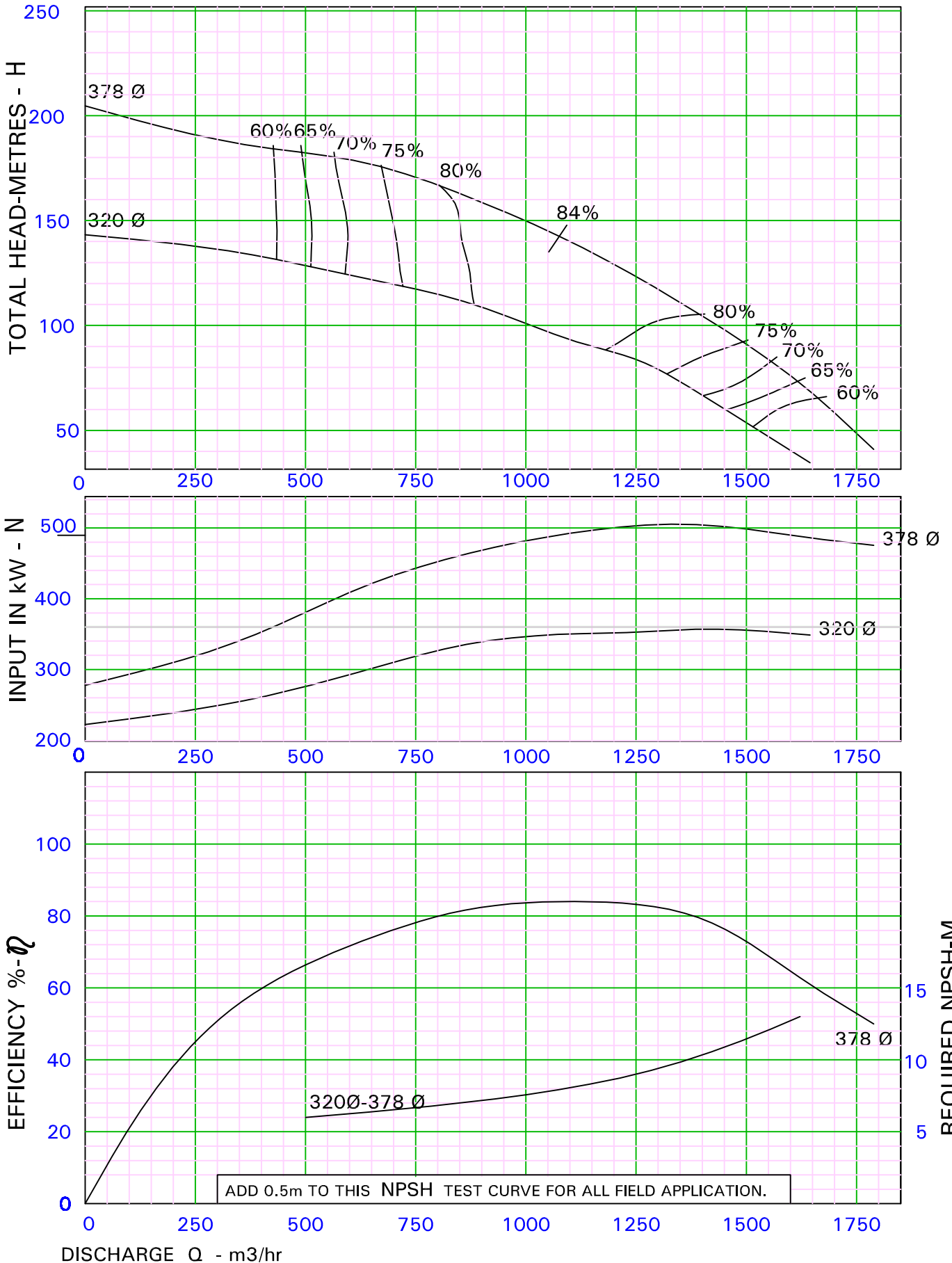

RECOMMENDED DELIVERY PIPE SIZE mm	200Ø	250Ø	300Ø	350Ø	400Ø	450Ø		
RECOMMENDED SUCTION PIPE SIZE mm	250Ø	300Ø	350Ø	400Ø	450Ø	500Ø	550Ø	600Ø

OUR GLOBAL PRESENCE



As we are constantly endeavouring to improve the performance of our products/ equipment, we reserve the right to make alterations from time to time and as such our products/ equipment may differ from that detailed in this publication. For latest information you may get in touch with our Regional Sales Offices.



Enriching Lives

KIRLOSKAR BROTHERS LIMITED

CORPORATE OFFICE :

"YAMUNA", Survey No. 98 (3/7), Baner,
Pune - 411045, INDIA
Tel.: +91 20 27214444 Fax: +91 20 27211117
email: kbline@kbl.co.in website: www.kbl.co.in

WORKS :

Kirloskarvadi 416308 Dist. Sangli
Maharashtra, INDIA
Tel.: +91 2346 222301 to 222305
Fax: +91 2346 222311

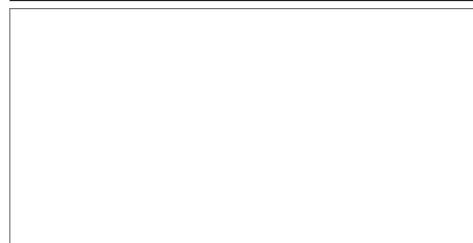

KIRLOSKAR BROTHERS LIMITED

EUROPE OFFICE : Kirloskar Brothers Europe BV Rooswijkweg 7-9, 1951 MH Velsen-Noord, The Netherlands. Tel : +31 (0) 251 270000 Fax : +31 (0) 251 272415
email: info@kirloskar.eu, website: www.kirloskar.eu